



THE BURJ AL ARAB HOTEL L'HÔTEL BURJ AL ARAB

United Arab Emirates / Émirates arabes unis
The world's greatest architectural designs /
Les plus grandes œuvres architecturales du monde



6+



- | | | | | |
|------------|-----------------------|-------------|--------------|-------------------|
| Creativity | Family Interaction | Observation | Reasoning | Fine motor skills |
| | | | | |
| Créativité | Interaction familiale | Observation | Raisonnement | Motricité fine |

1368 PCS

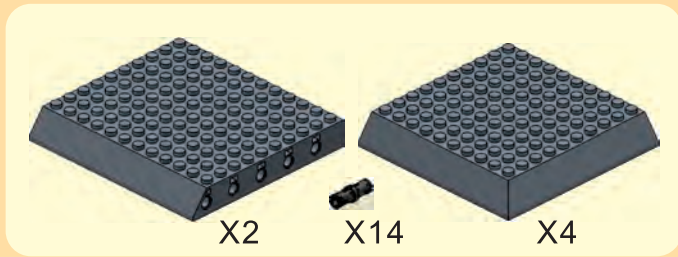

1

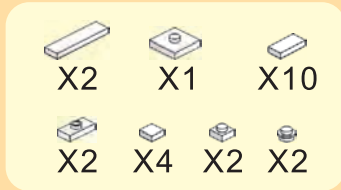
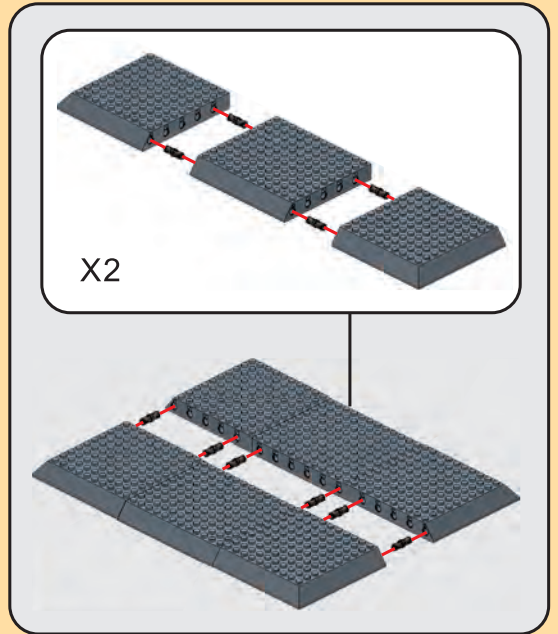
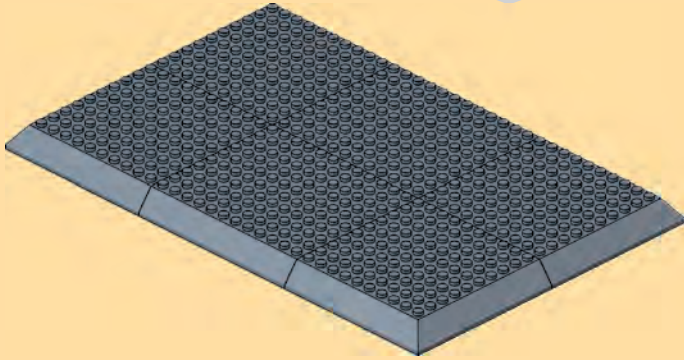

2

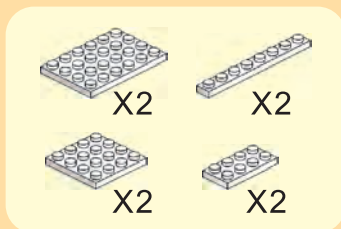
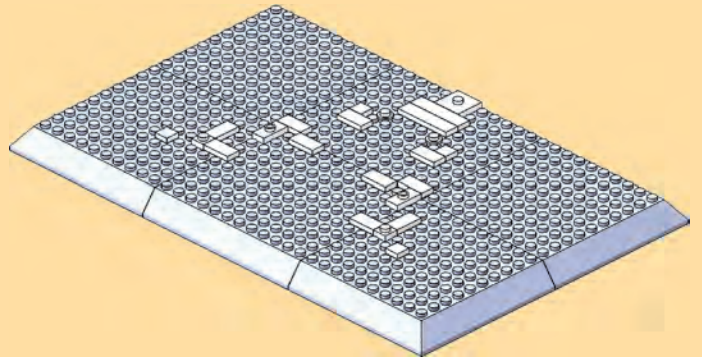

3

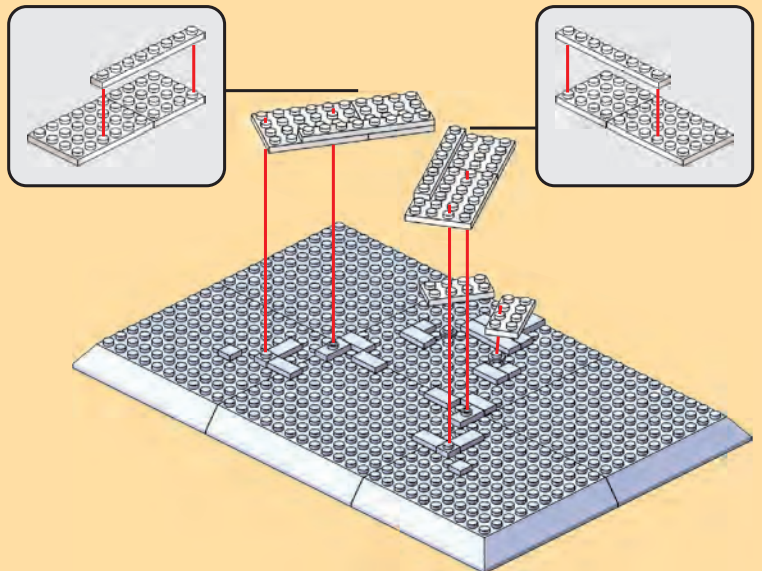

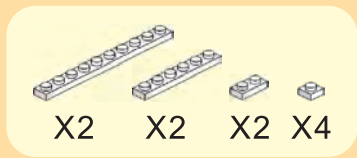

4

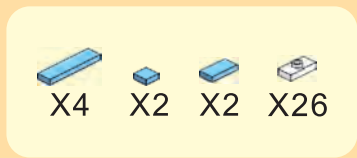
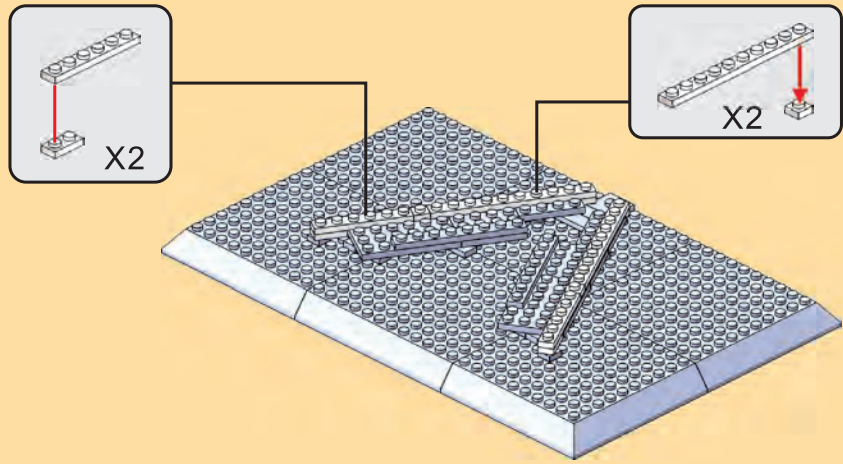

5

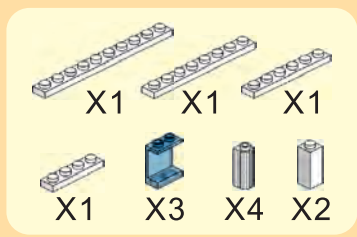
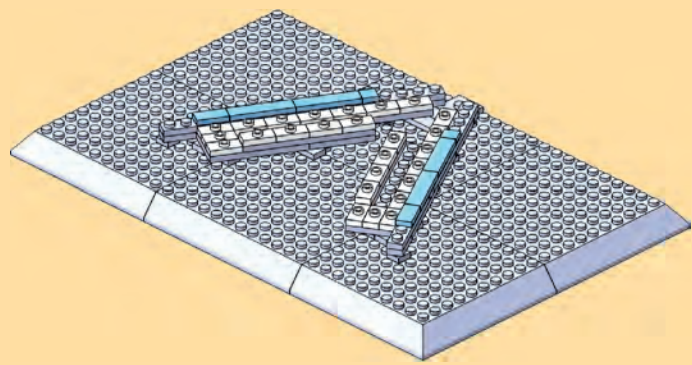



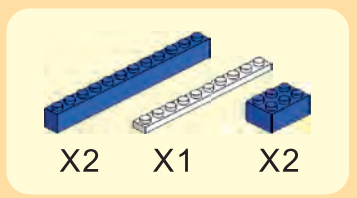
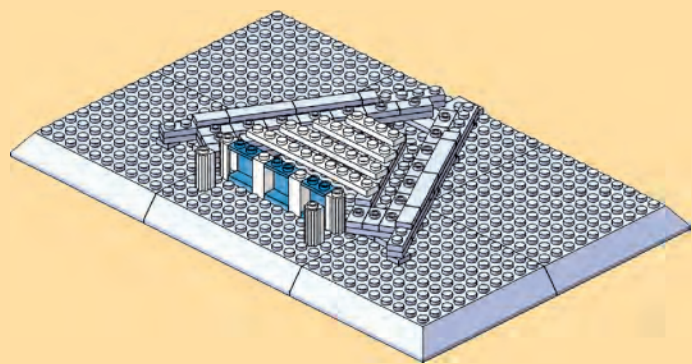

6

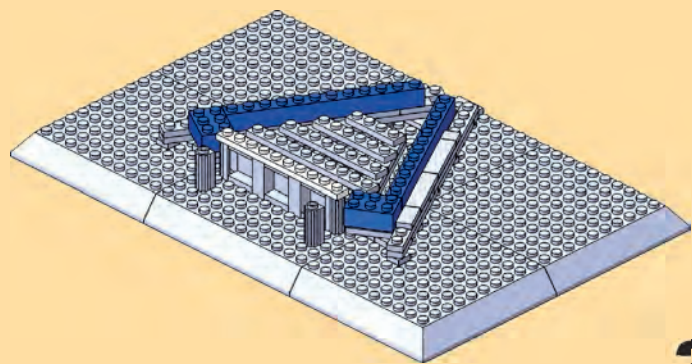



7



- X4 
- X18 
- X2 
- X2 

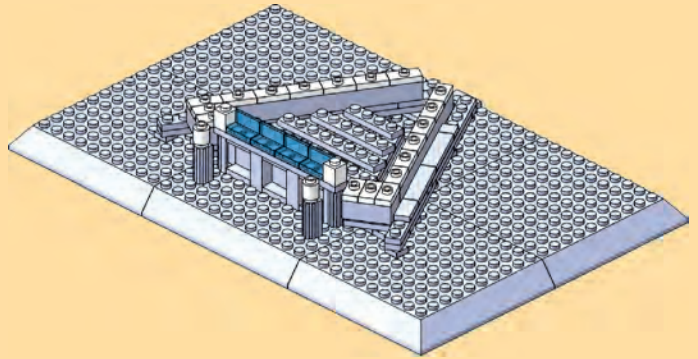

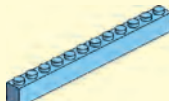

8

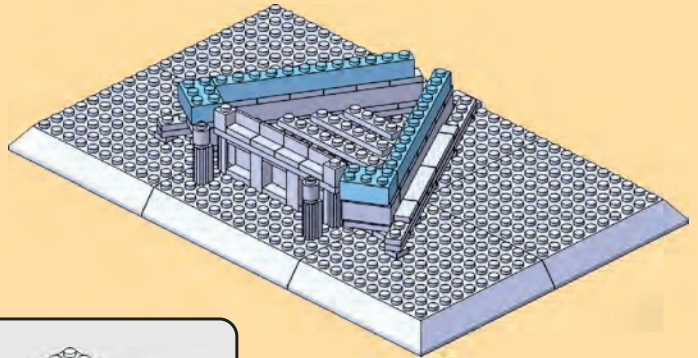

- X2 
- X2 

9





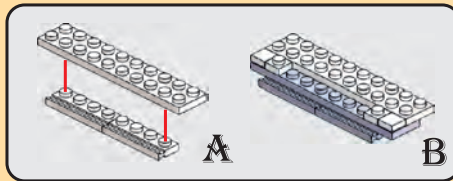



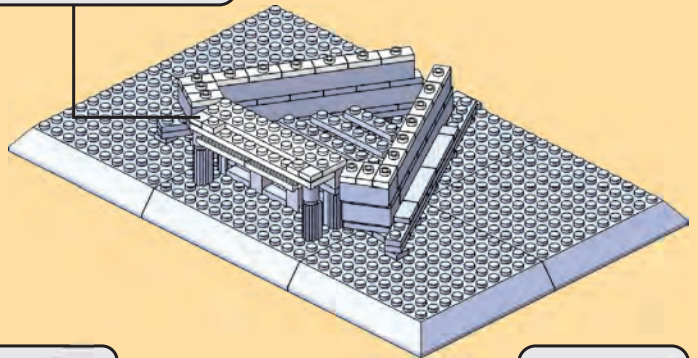

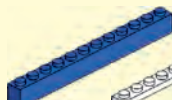
- X18 
- X2 
- X2 
- X2 
- X2 



10



- X2 
- X2 
- X2 
- X2 
- X2 
- X4 
- X1 
- X1 

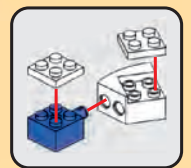
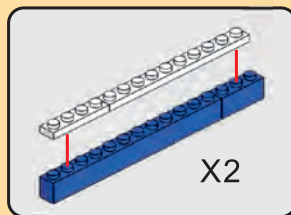

11

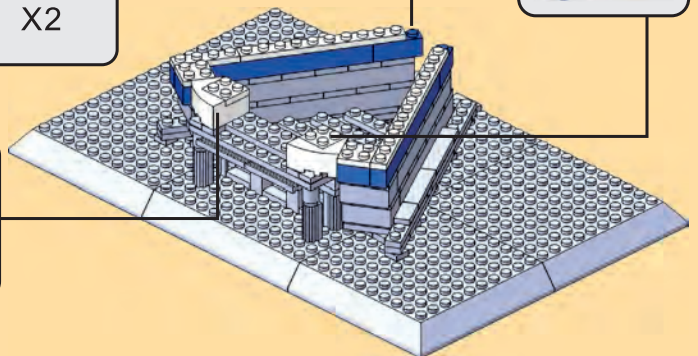
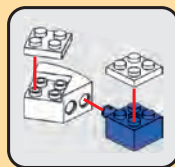

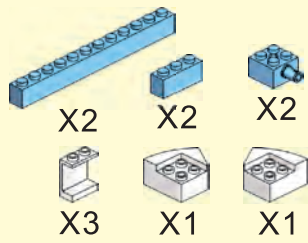

12

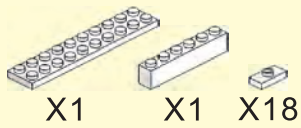
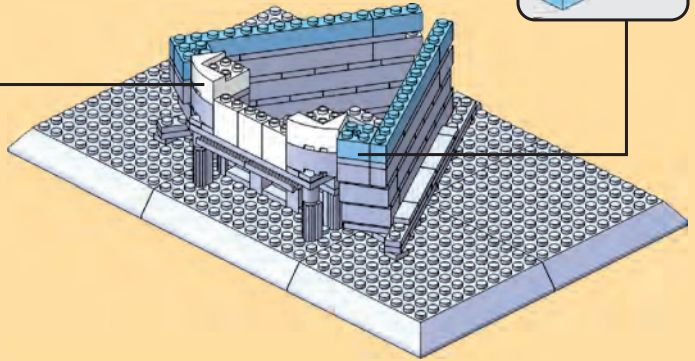
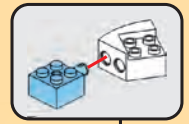
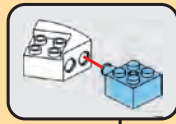

13

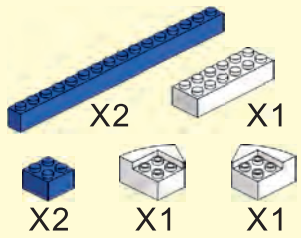
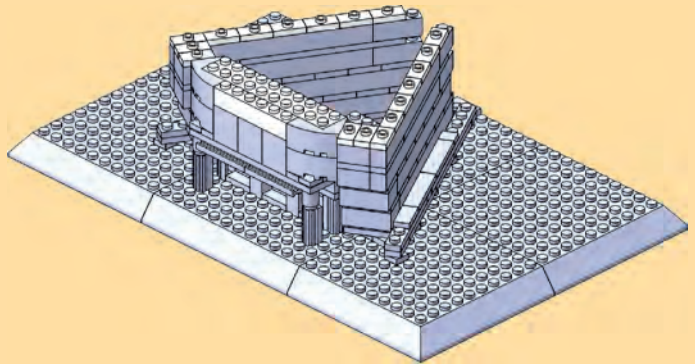

14

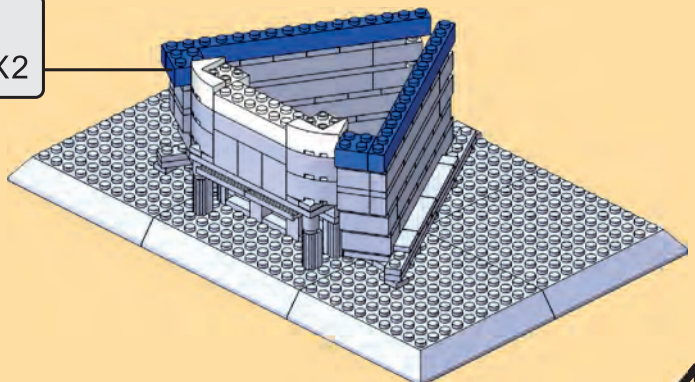

- X2
- X2
- X6
- X2
- X6
- X10

15

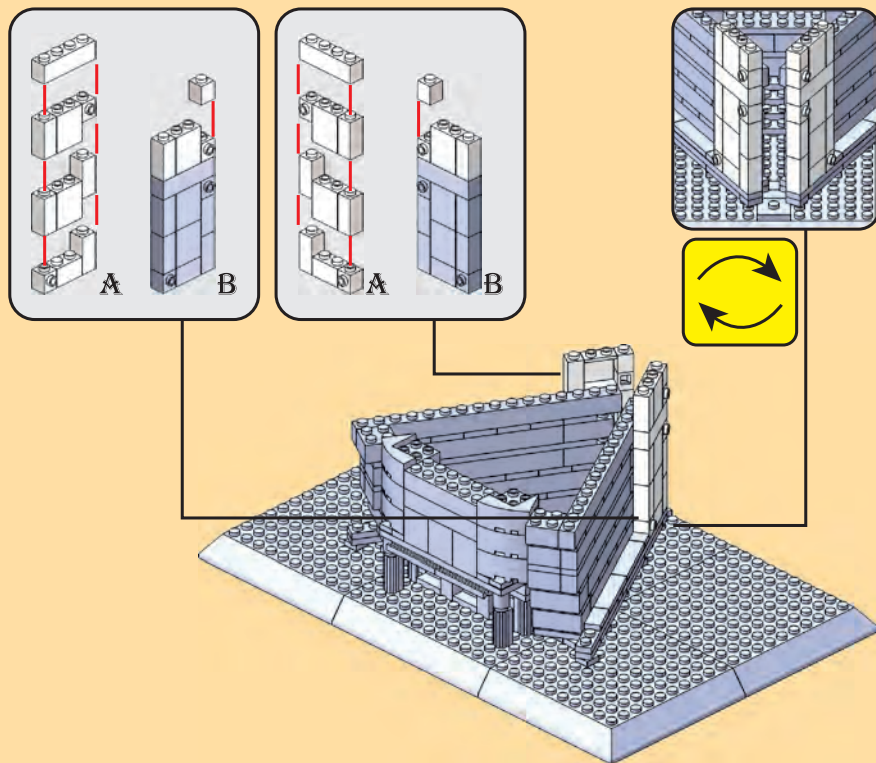

- X2
- X1
- X2
- X3
- X2
- X2
- X7
- X1
- X2

16

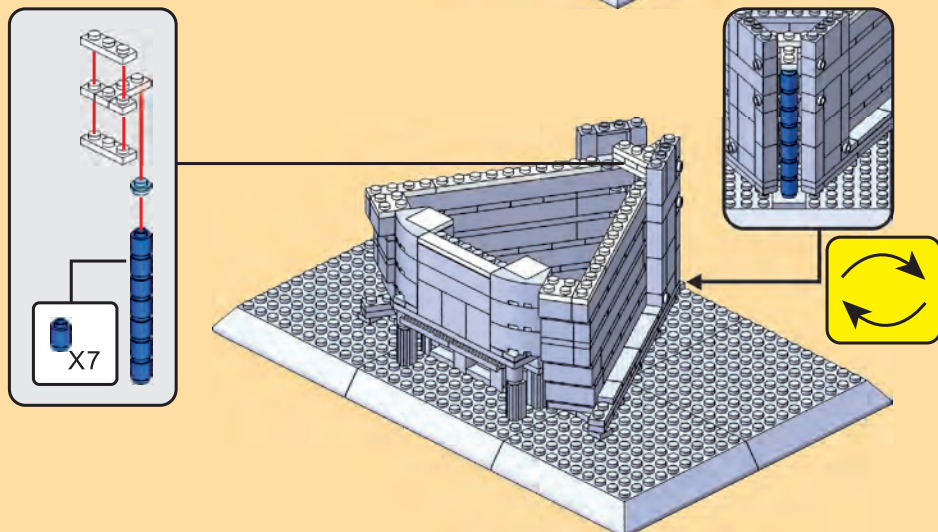

- X2
- X2
- X4
- X2
- X1
- X1

17

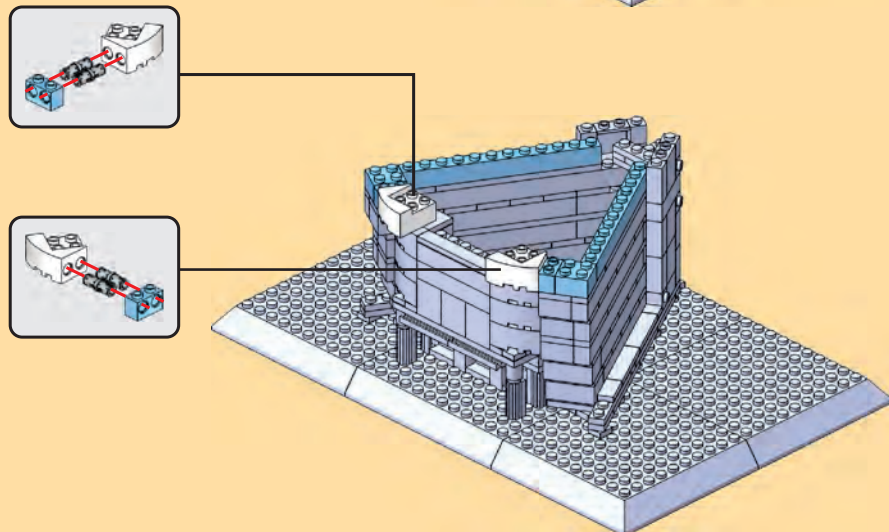

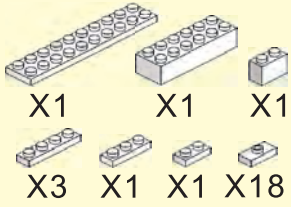

18

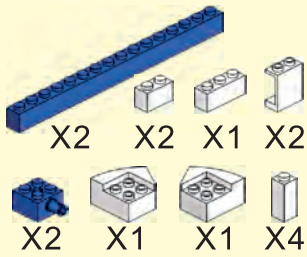
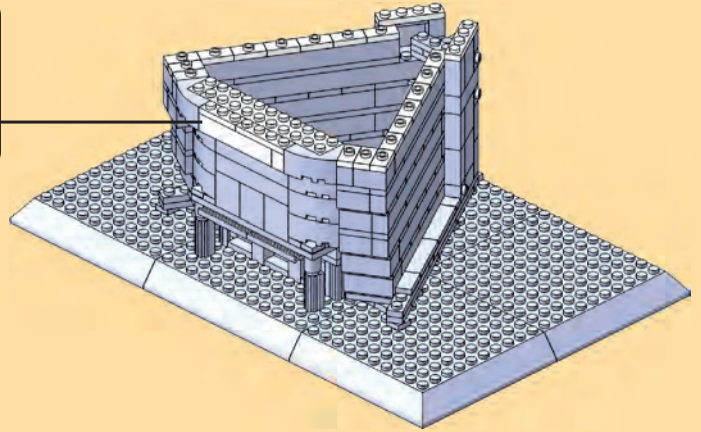
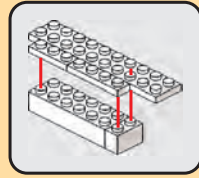

19

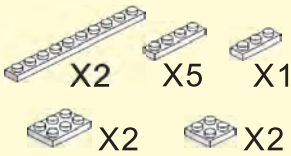
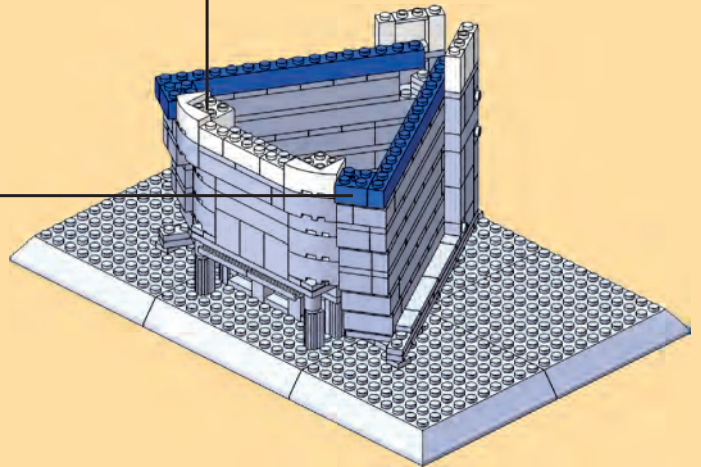

20

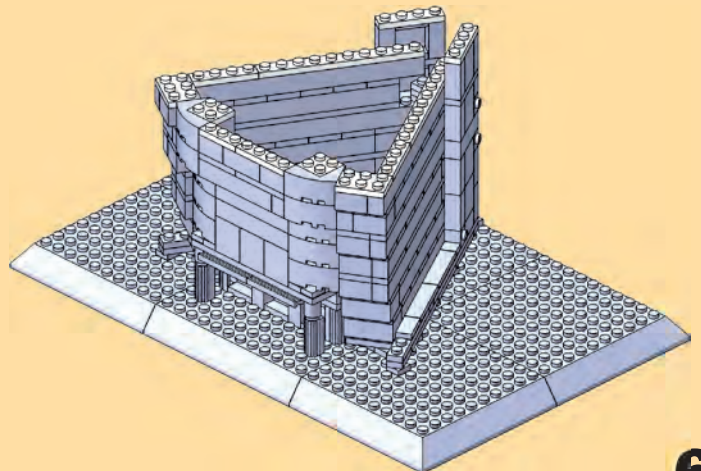



X8



X1



X1



X2



X2



X1

21

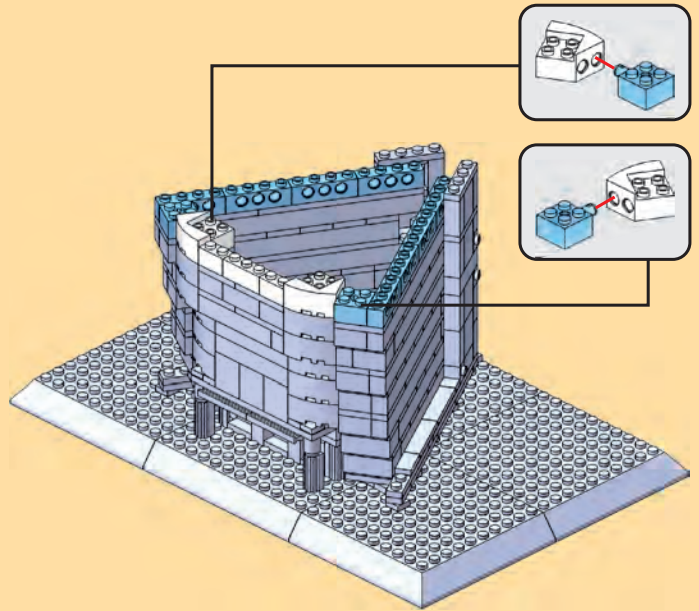

X1



X2



X20



X1

22

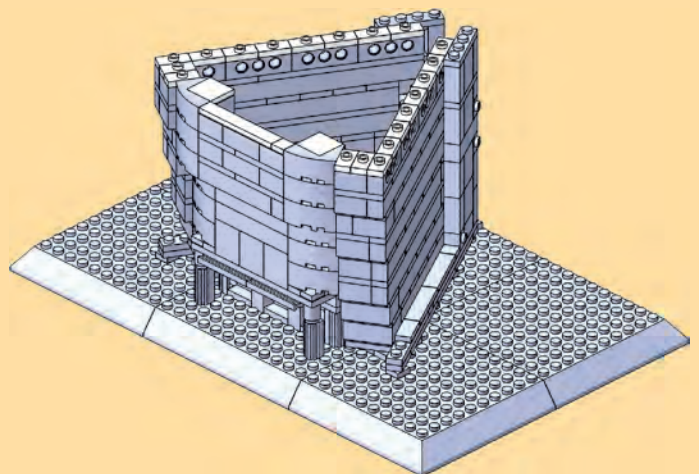

X4

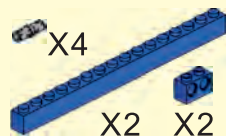

X2



X2



X2









X1

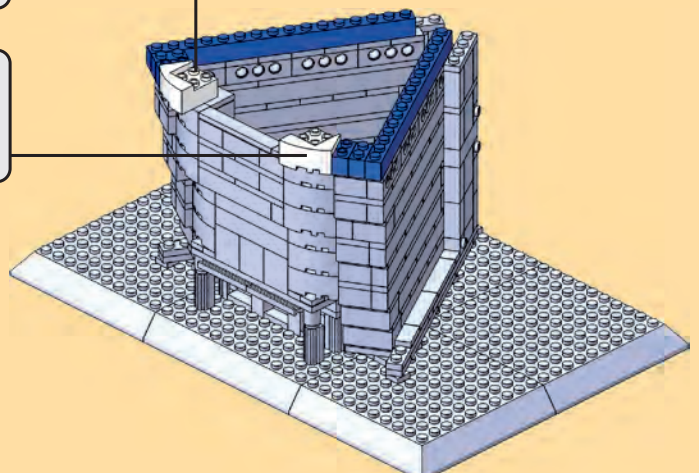
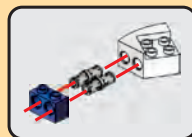
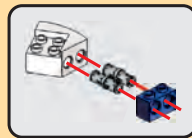

X1







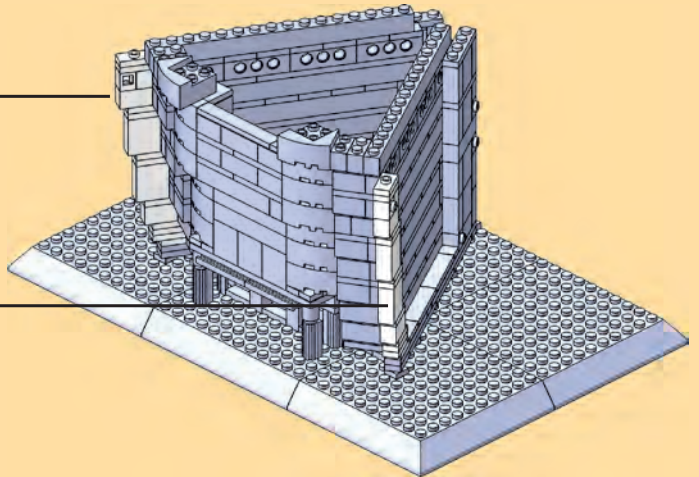
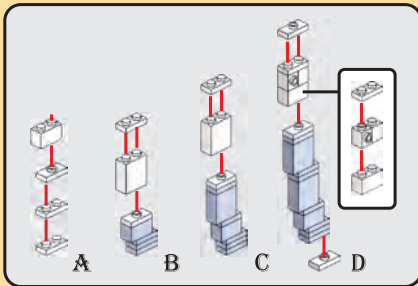
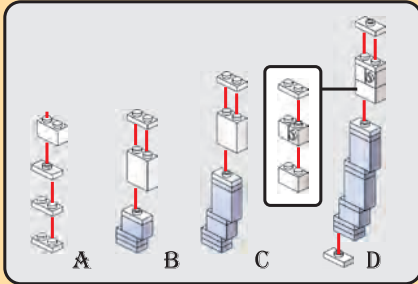

23

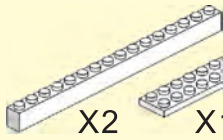
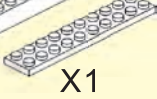

-  X4
-  X4
-  X2
-  X12
-  X10
-  X2

24



-  X2
-  X1
-  X4
-  X2
-  X2
-  X2
-  X4
-  X2
-  X4

25

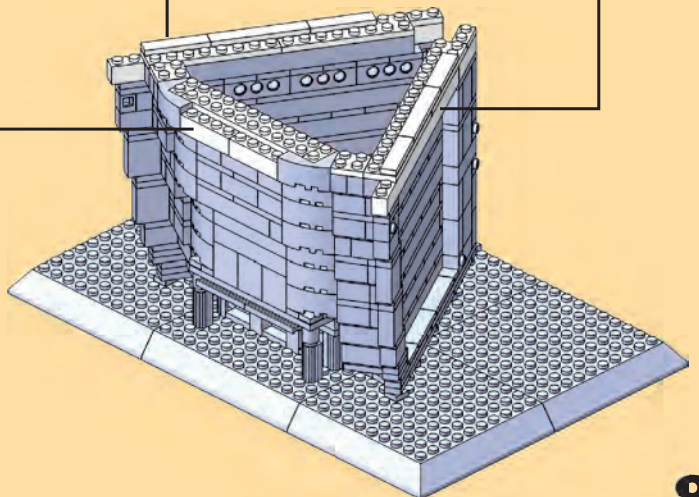
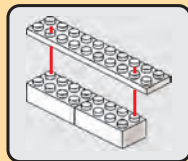
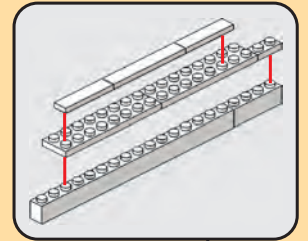
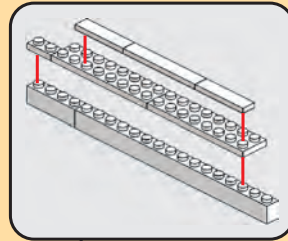

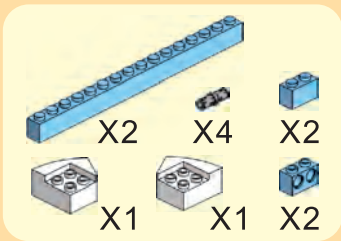

26

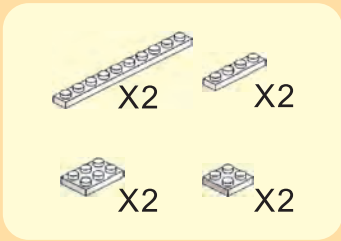
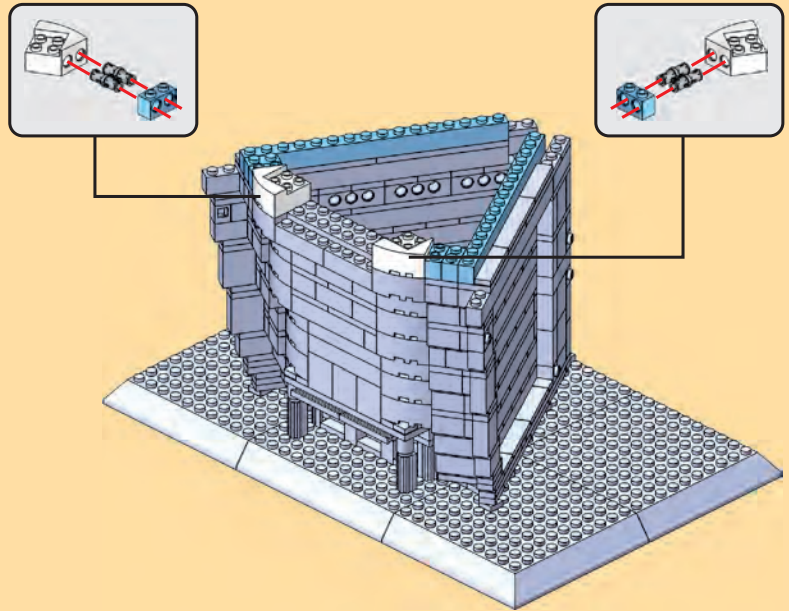

27

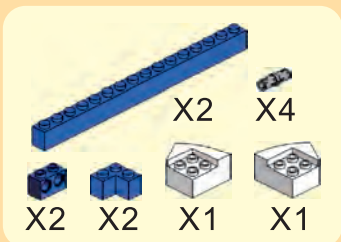
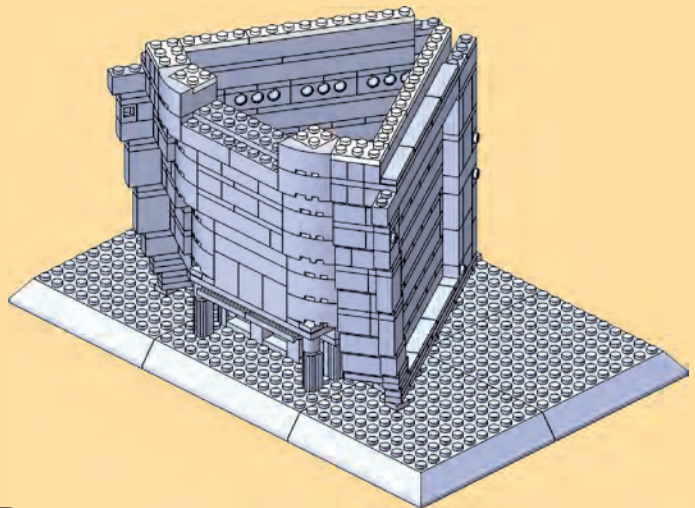

28

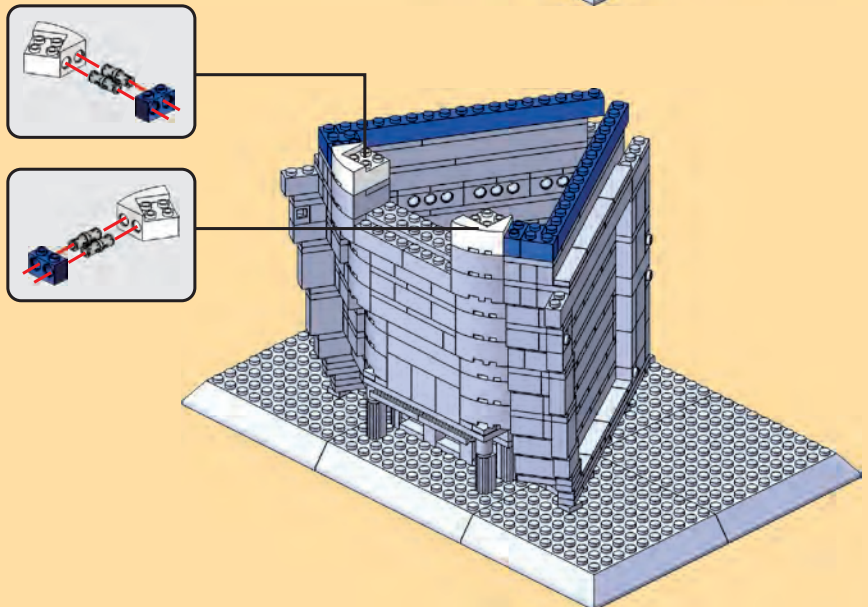

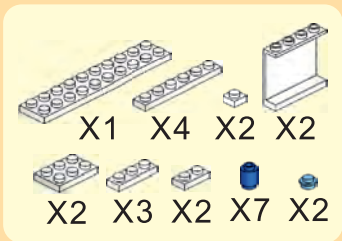

29

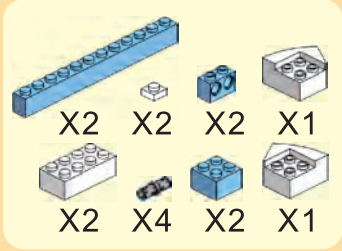
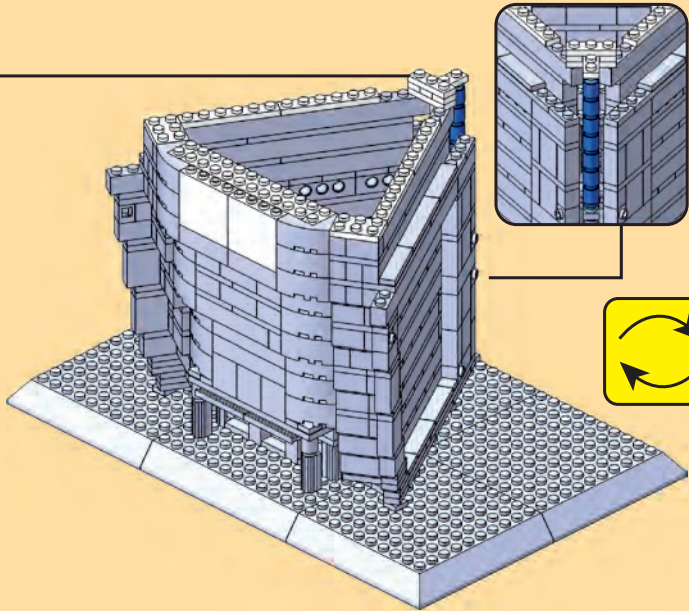
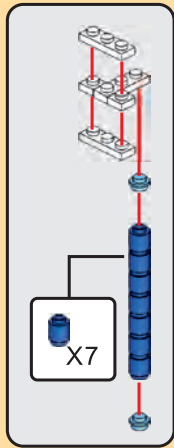

30

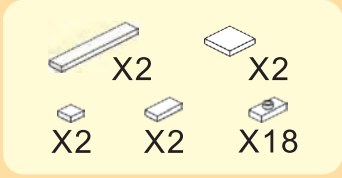
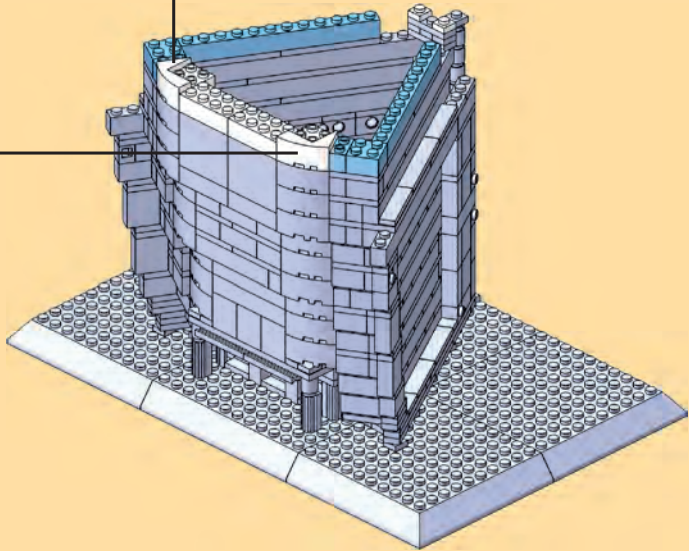
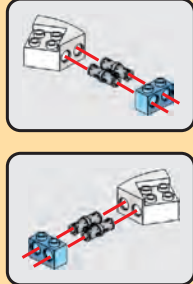

31

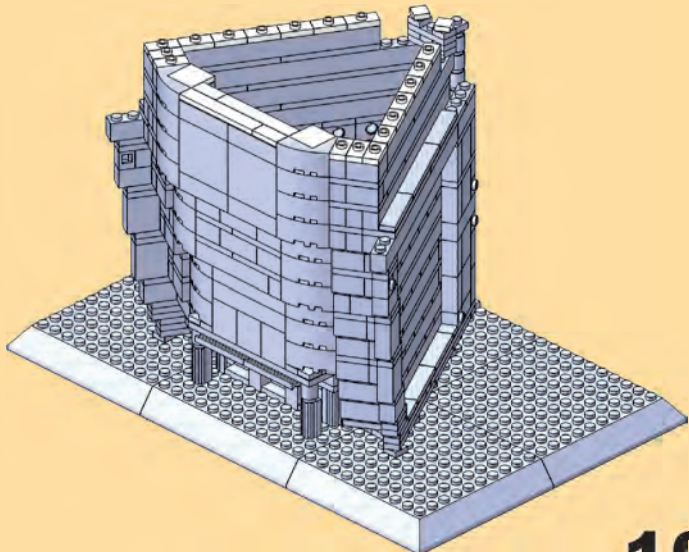

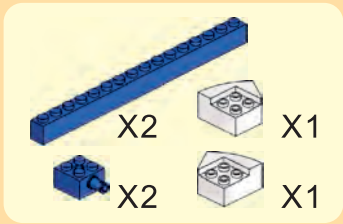

32

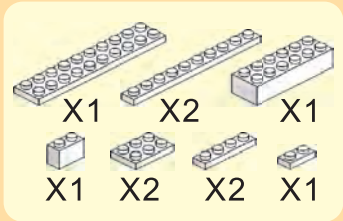
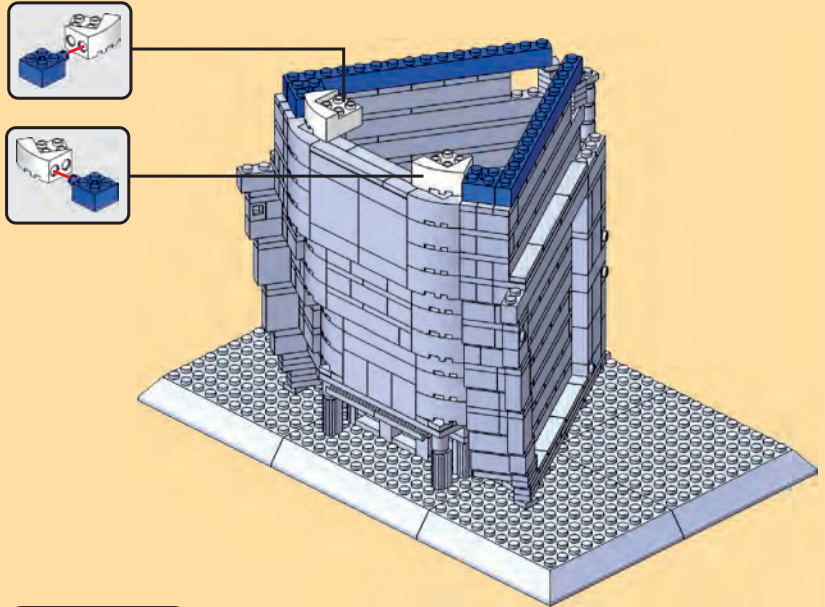

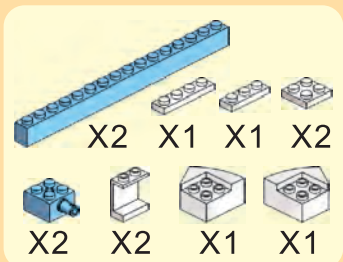
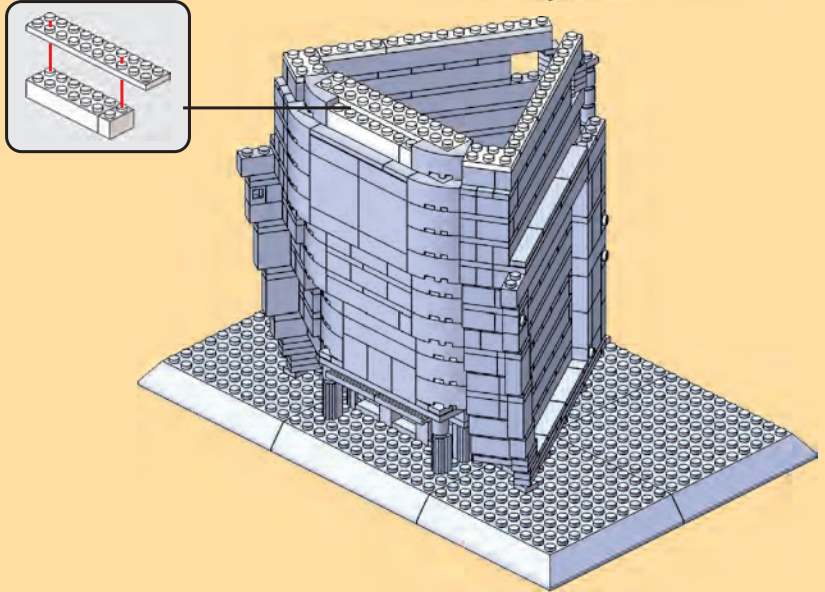

33



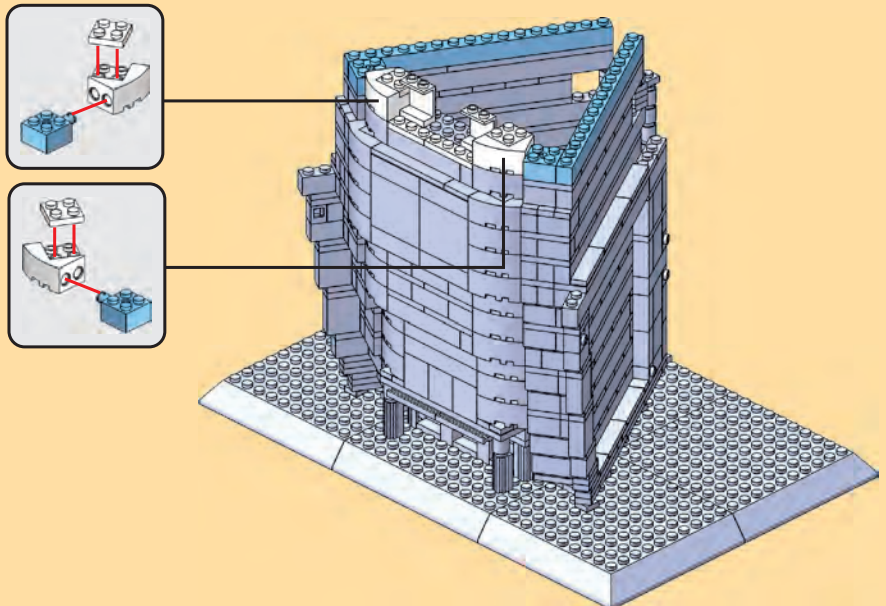





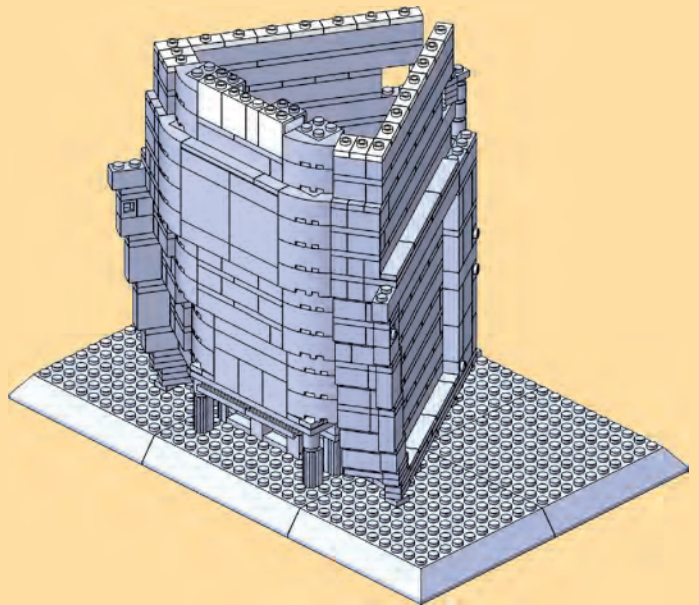

34



- 
X20
- 
X1
- 
X3





35

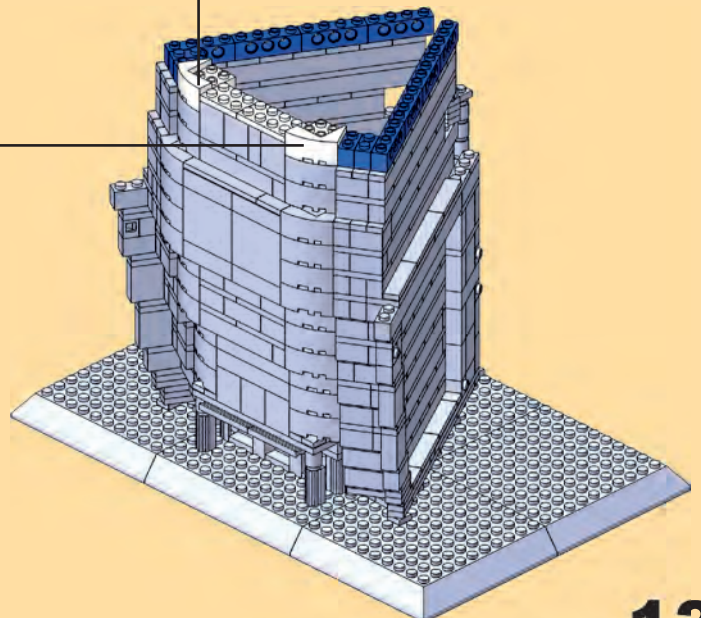
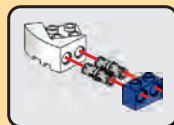

- 
X1
- 
X1
- 
X8
- 
X2
- 
X1
- 
X1
- 
X4
- 
X2





36

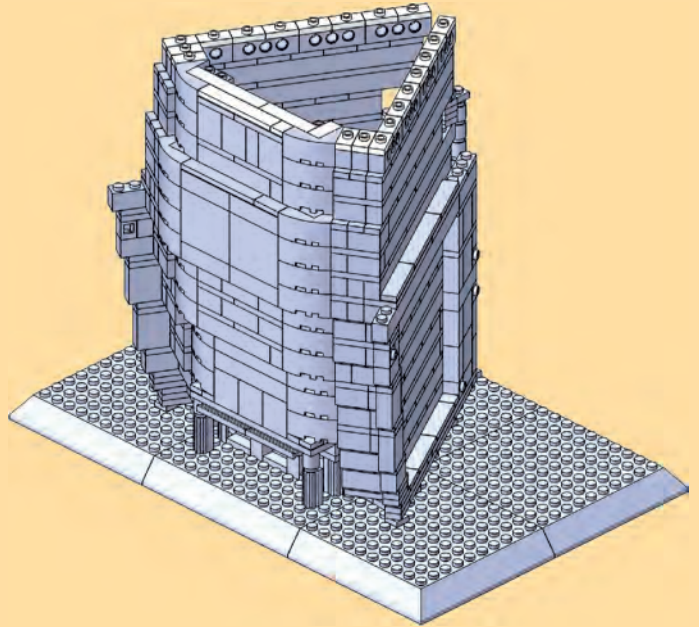

-  X2
-  X1
-  X20
-  X1
-  X1

37



-  X4
-  X2
-  X2
-  X4
-  X6

38

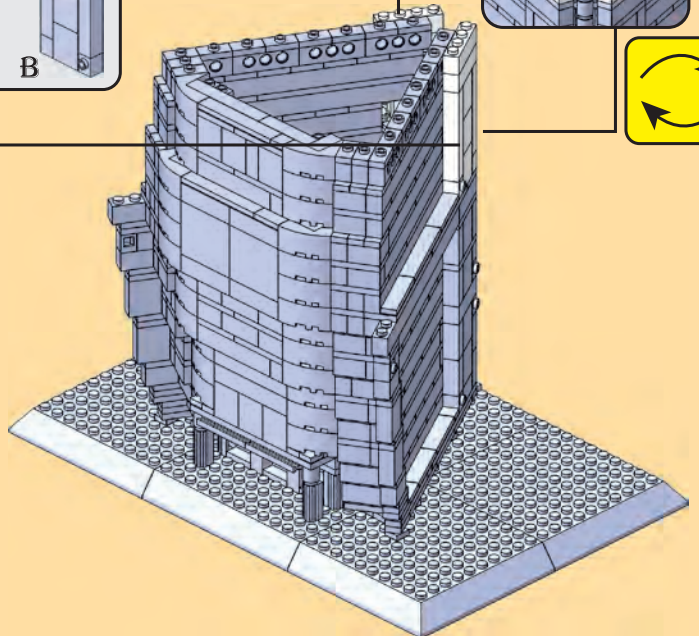
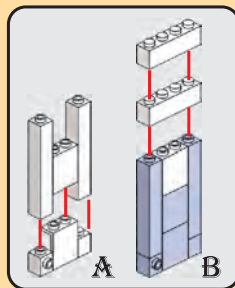
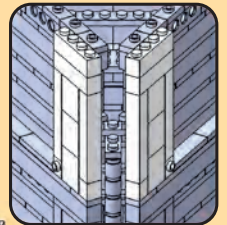
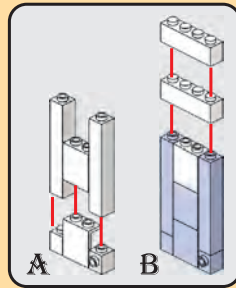



X6



X2



X2



X4



X4



X2

39

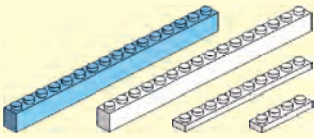
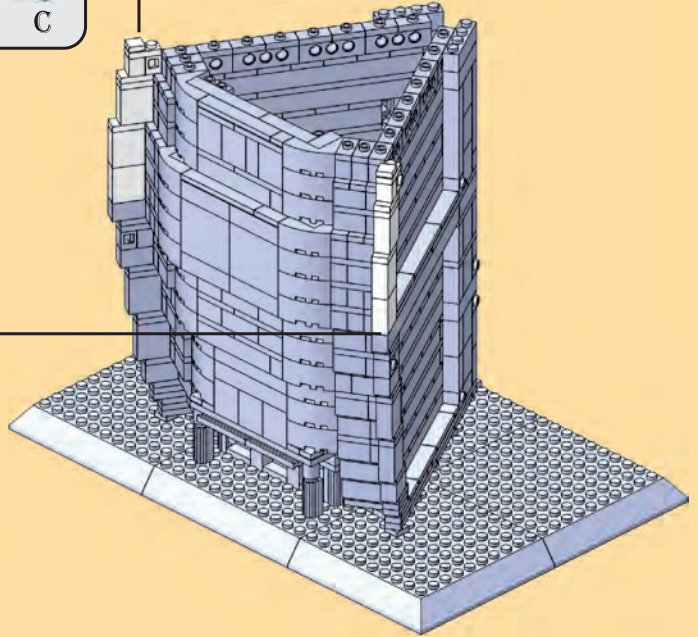
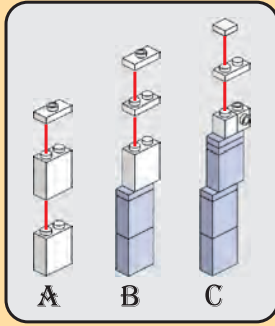
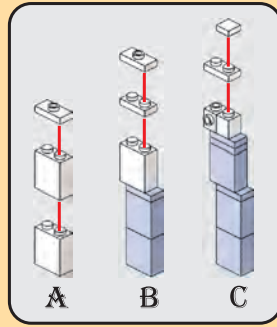

X2

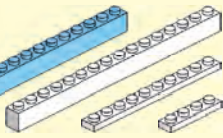

X2

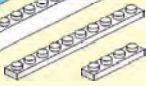

X2



X4



X2



X1



X1



X2

40

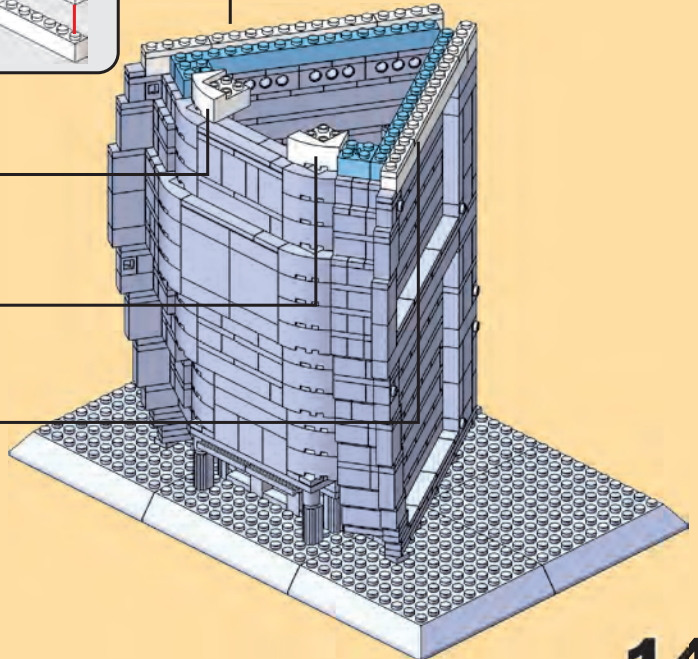
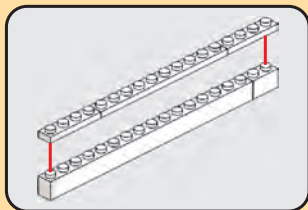
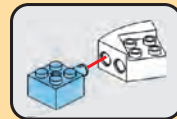
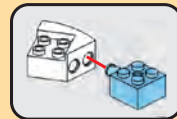
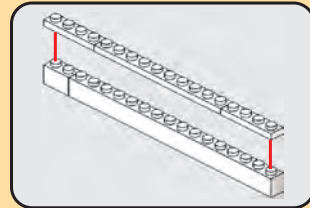

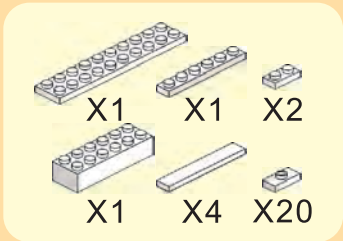



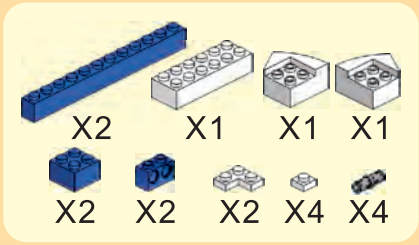
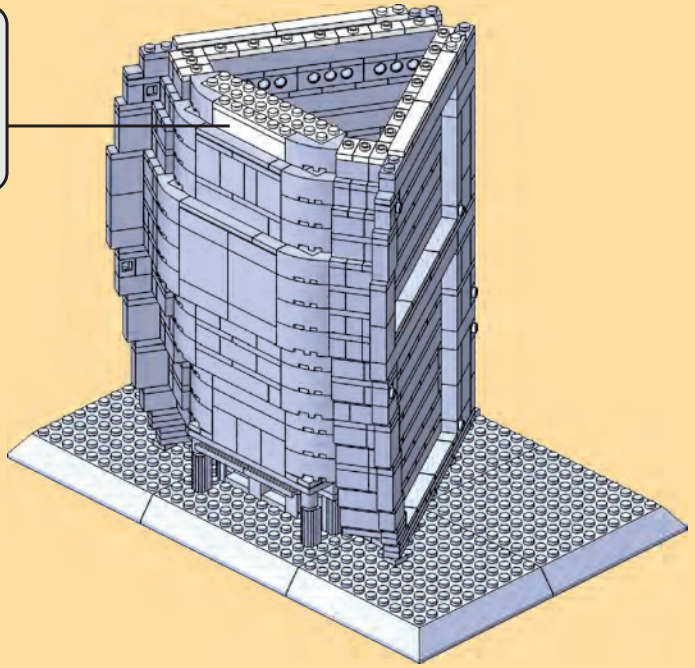
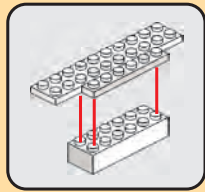



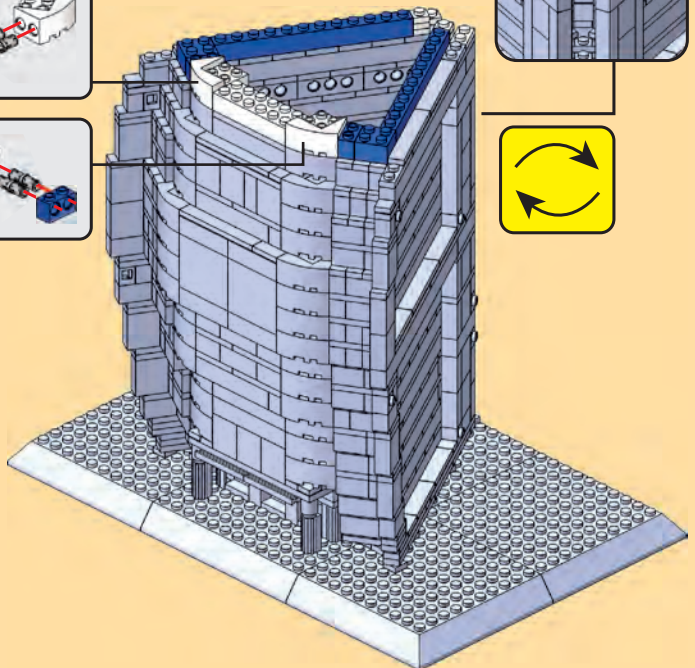
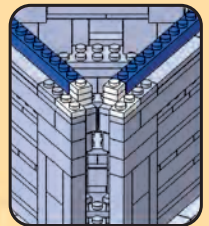
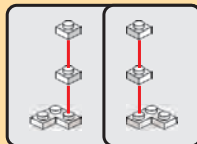

41









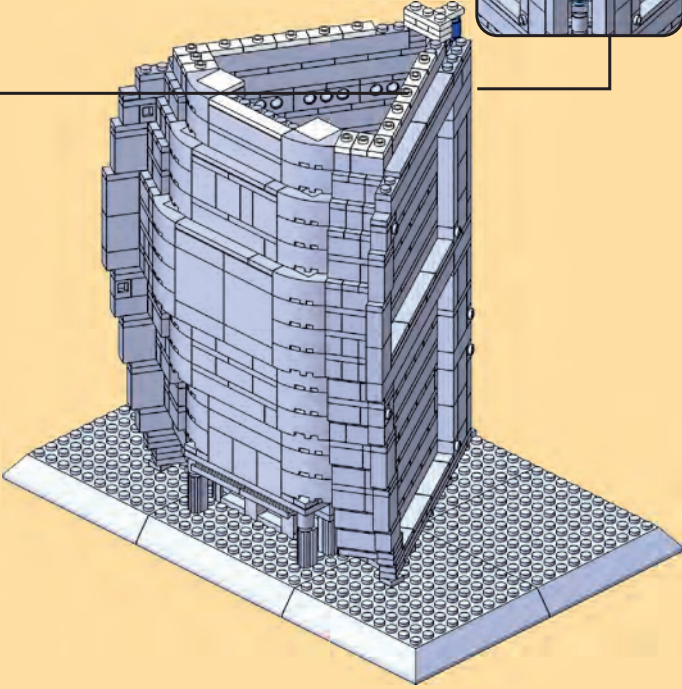
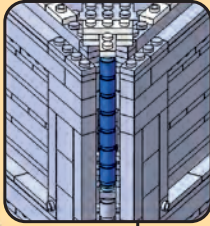
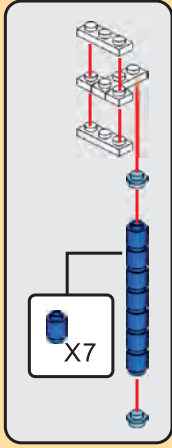

42



-  X1
 X2
 X3
-  X7
 X16
 X2
 X2

43



-  X1
 X1
-  X2
 X1
 X1
-  X2
 X1
 X1

44

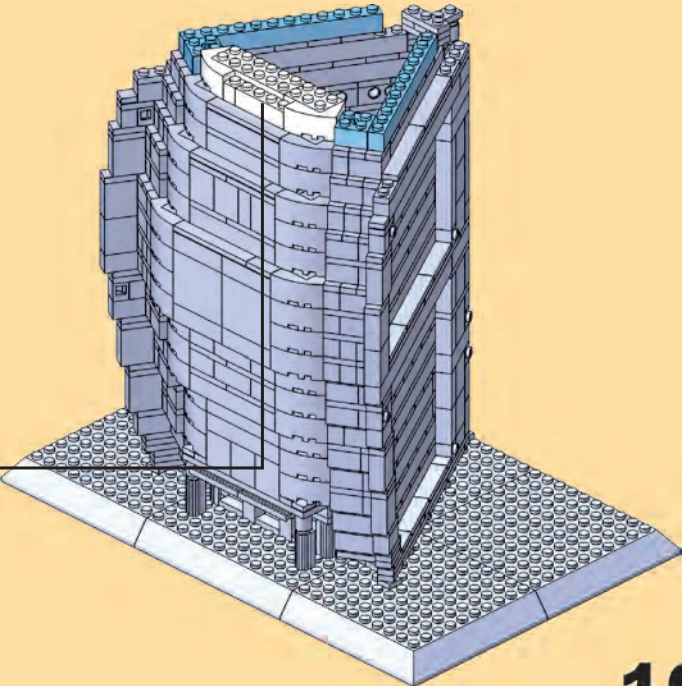
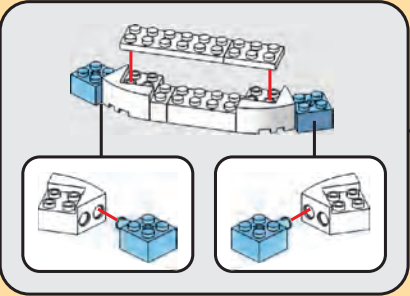



X1



X16



X1

45

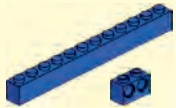
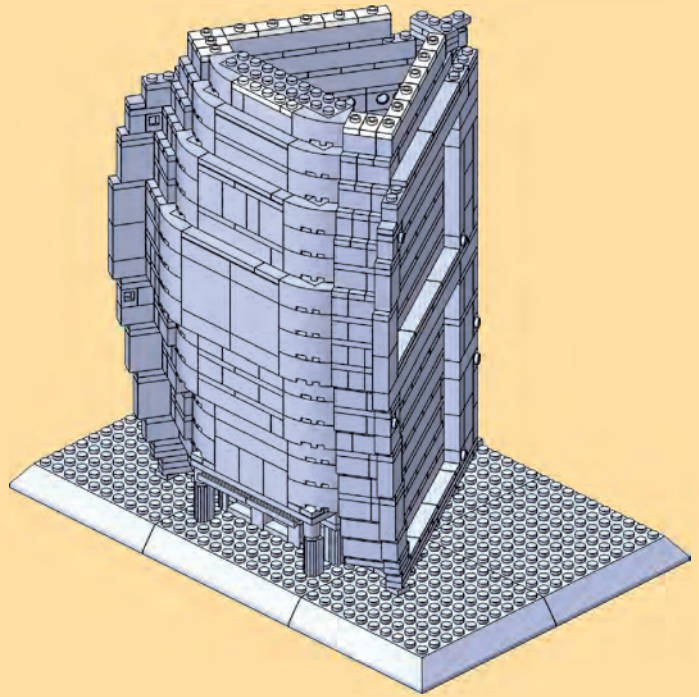

X2



X2



X2



X4



X4



X1



X1



X1



X1

46

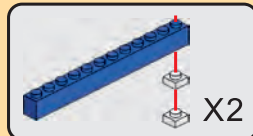

X2

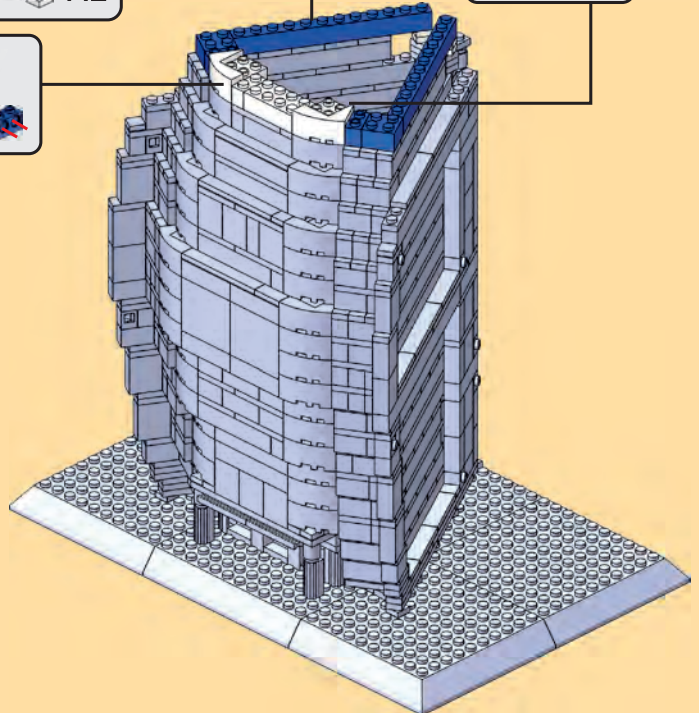
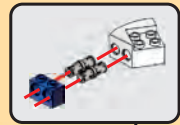



X3



X18



X2

47

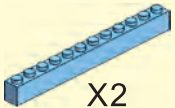
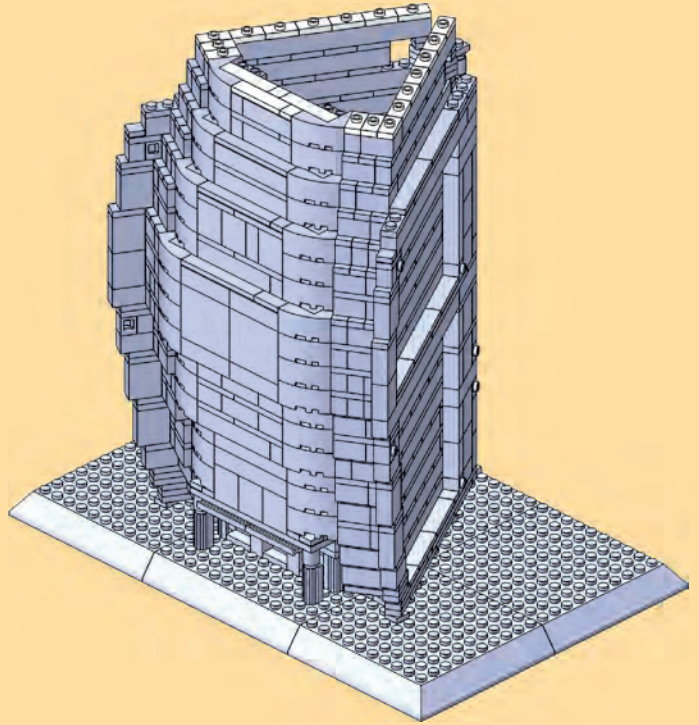

X2



X2







X1

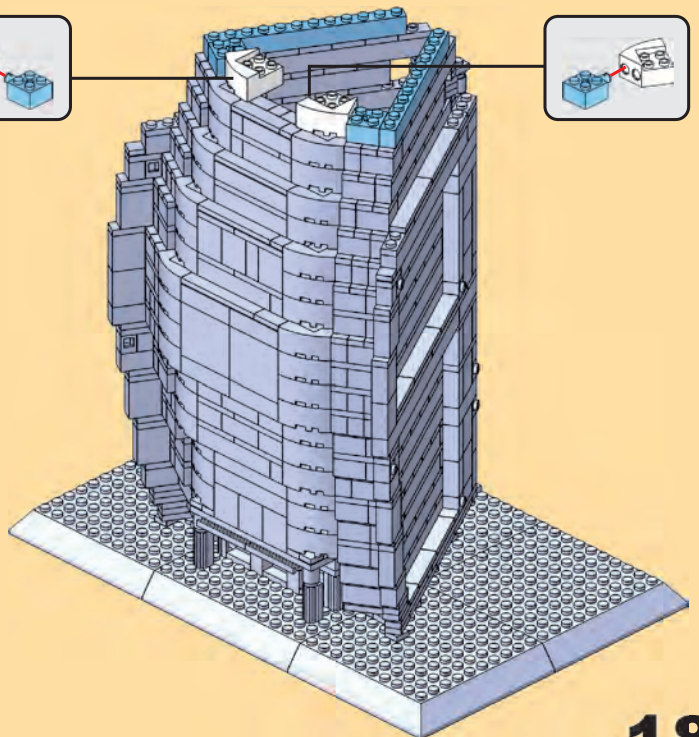

X1

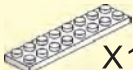





48

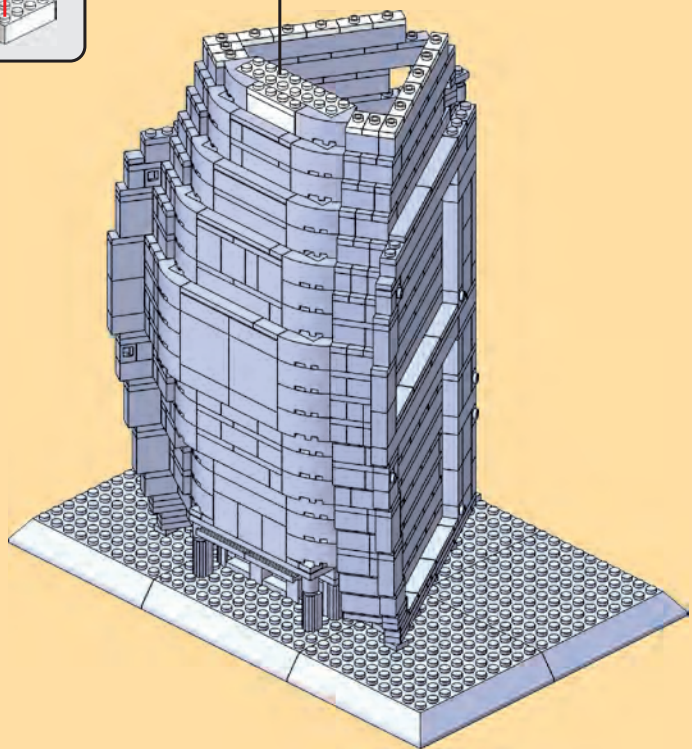
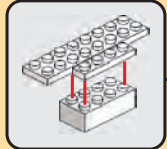

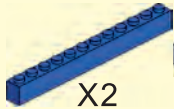
- X1 
- X16 
- X1 
- X1 

49



- X2 
- X1 
- X4 
- X2 
- X2 
- X1 
- X1 

50

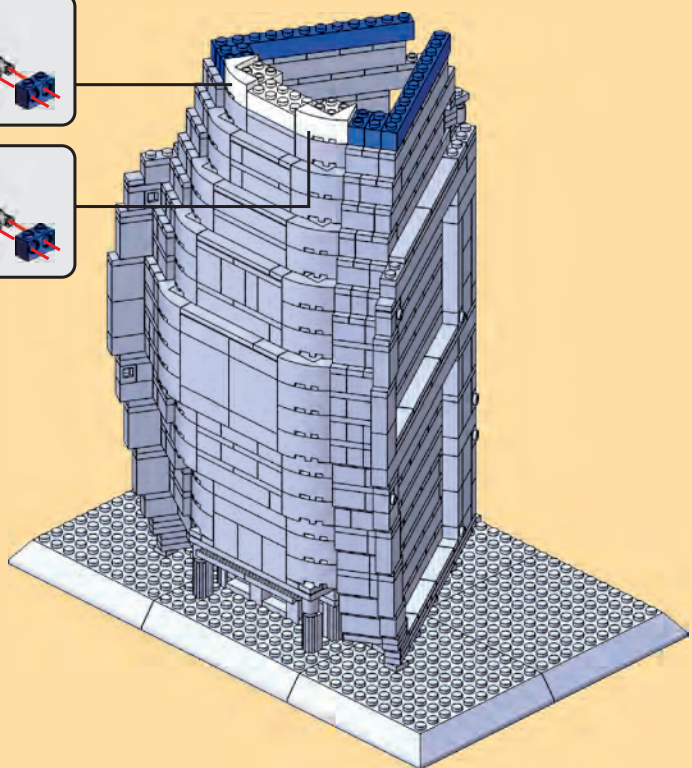
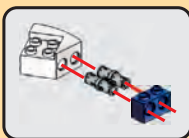
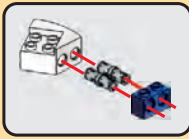



X3



X16

51

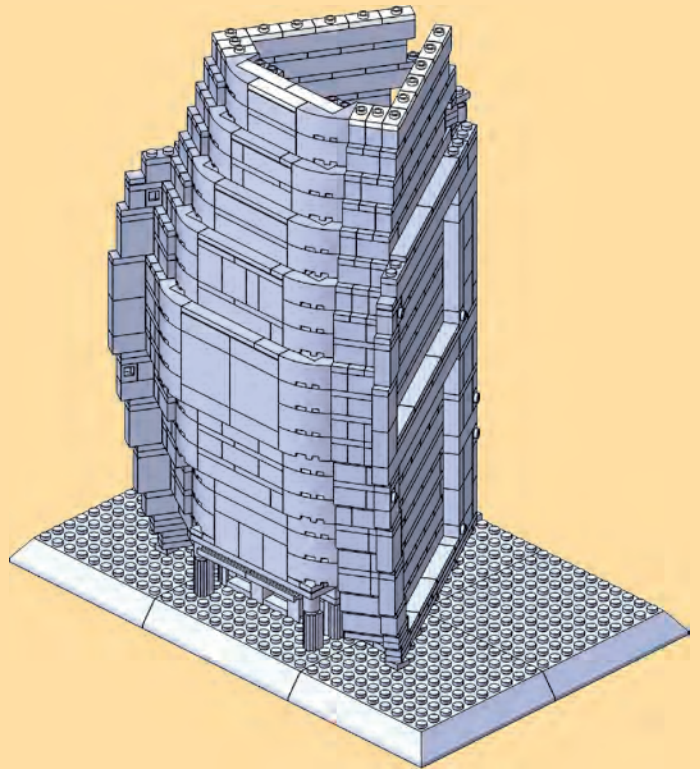

X6



X2



X1



X1

52

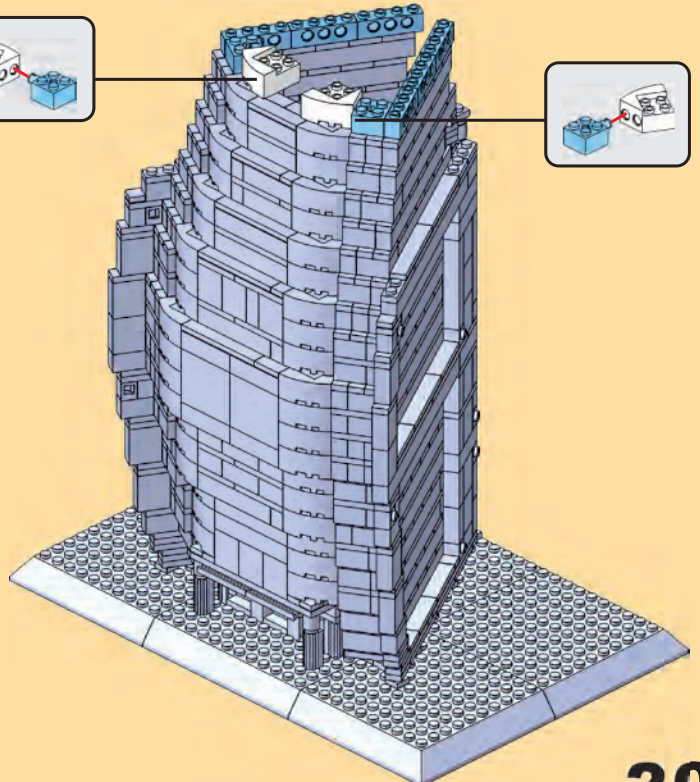

- X1
- X1
- X1
- X1
- X16



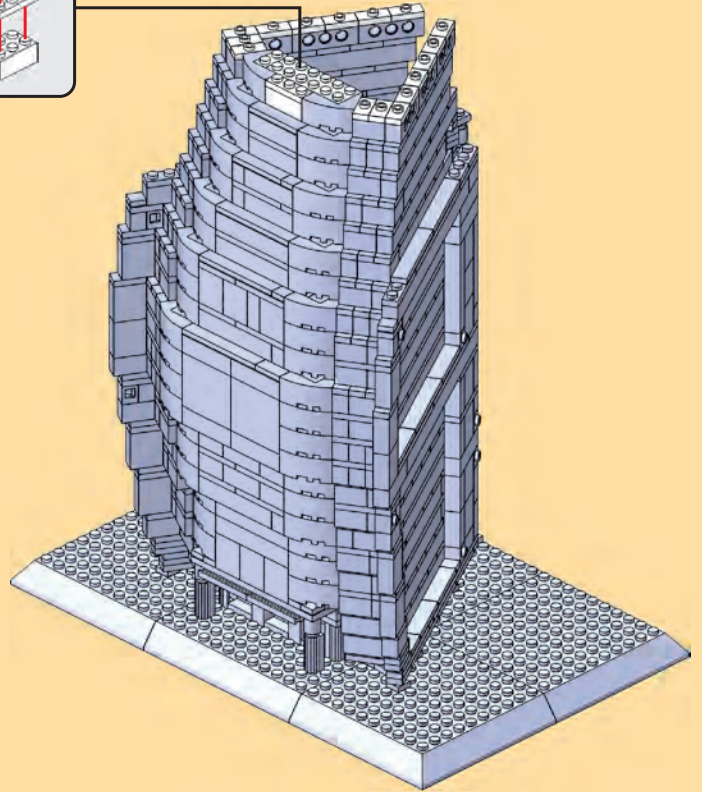
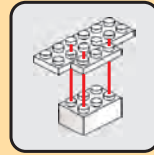

53

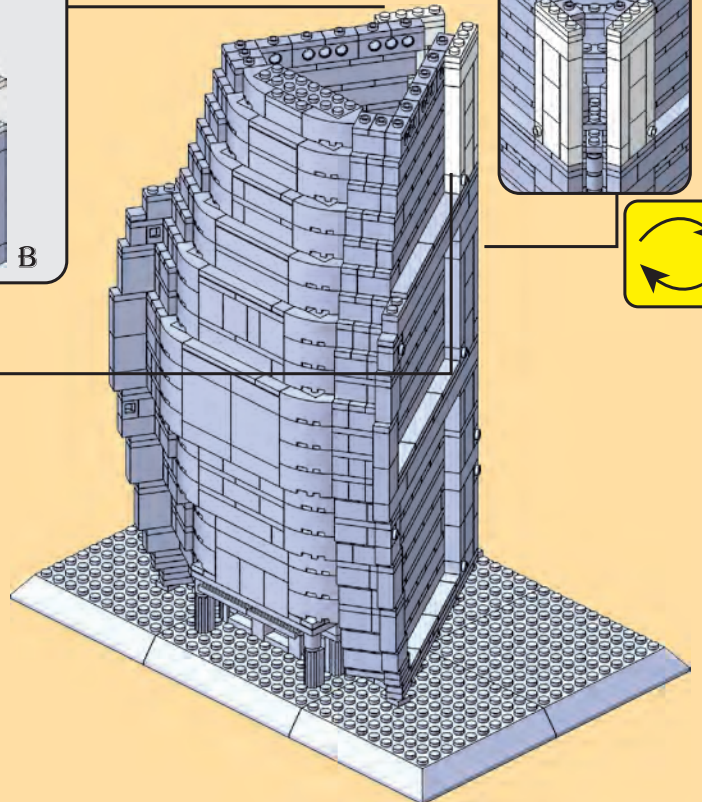
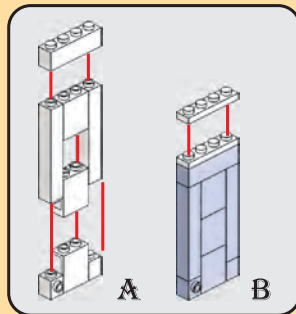
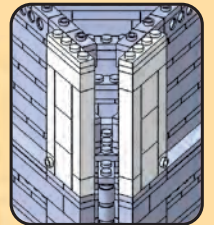
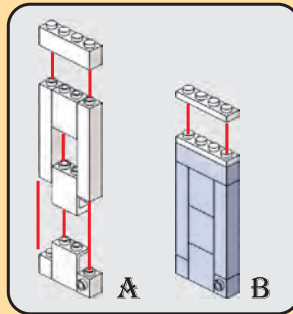

- X4
- X6
- X2
- X2
- X2
- X4







54

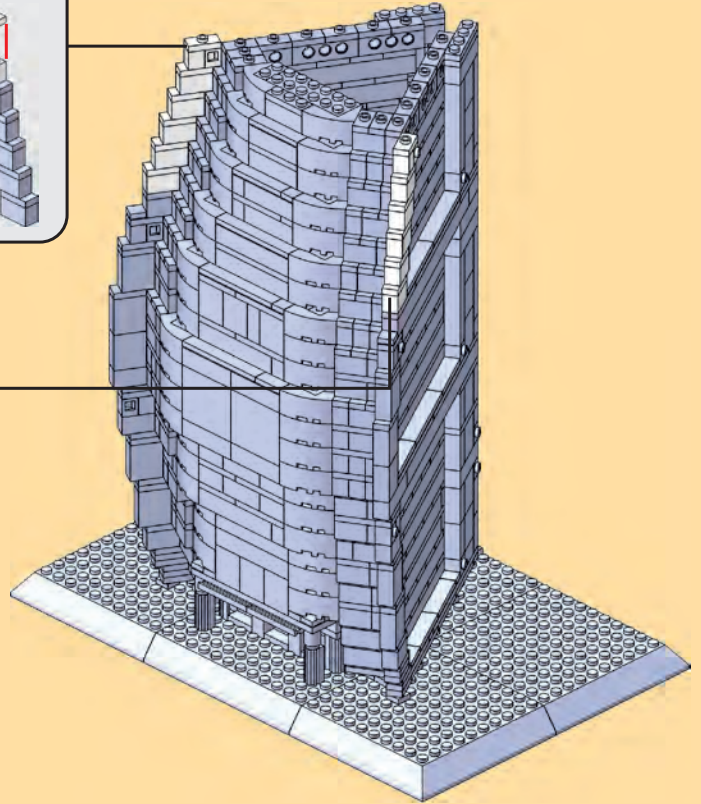
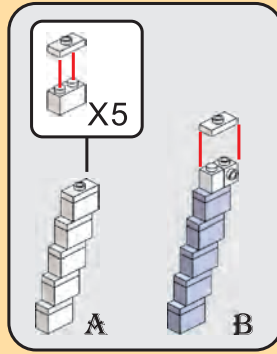
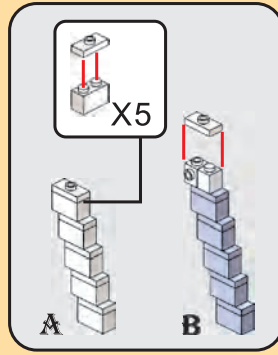

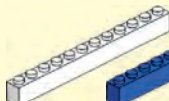
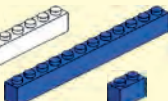
-  X10  X2
-  X12  X2

55



-  X2  X2  X2  X4
-  X1  X1  X1  X2

56

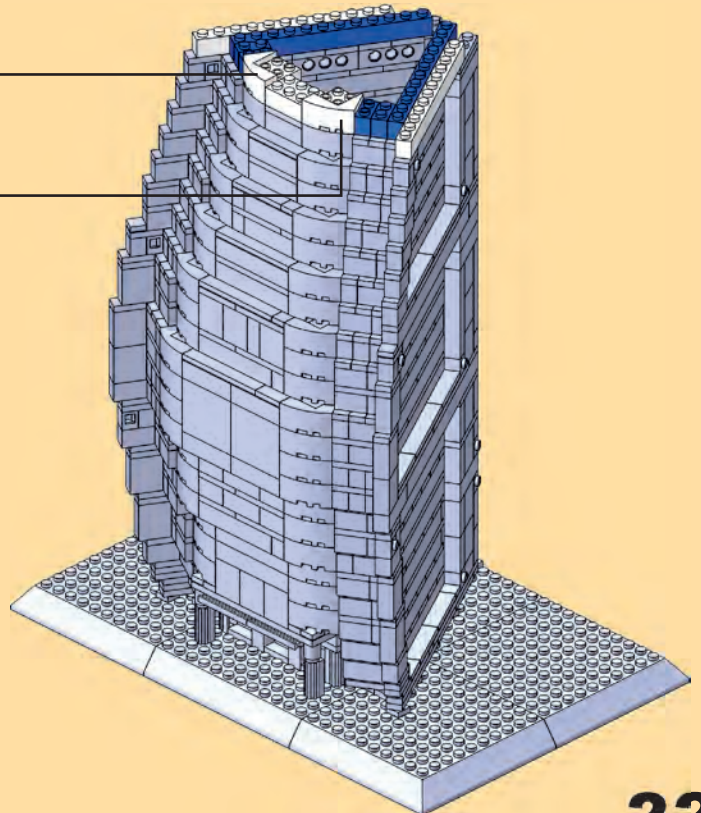
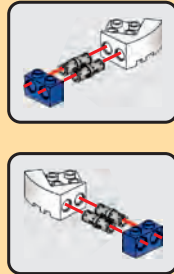

- X2
- X2
- X4
- X7
- X3
- X1
- X3
- X6
- X2



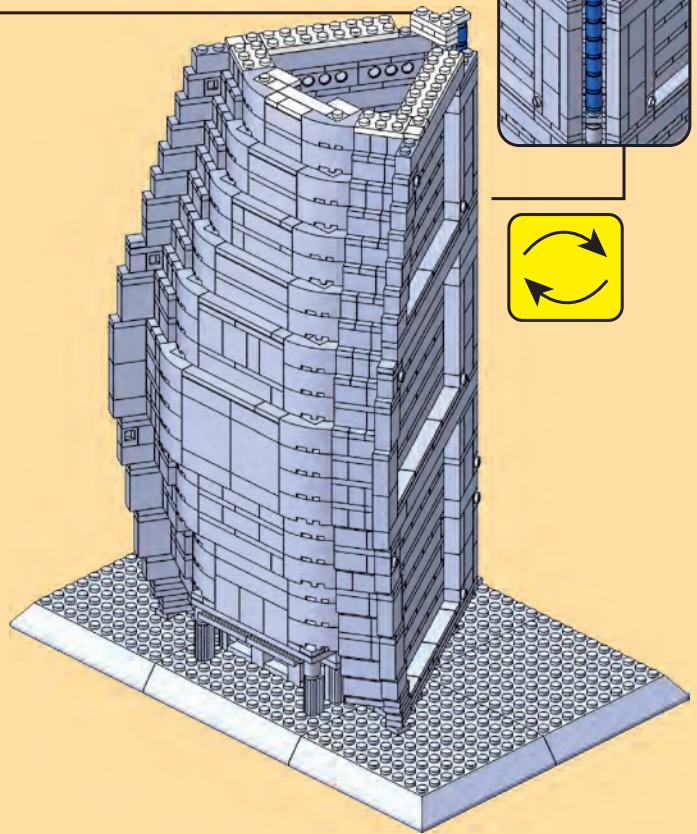
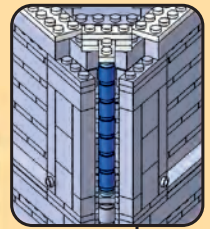
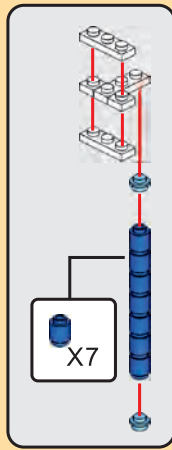

57

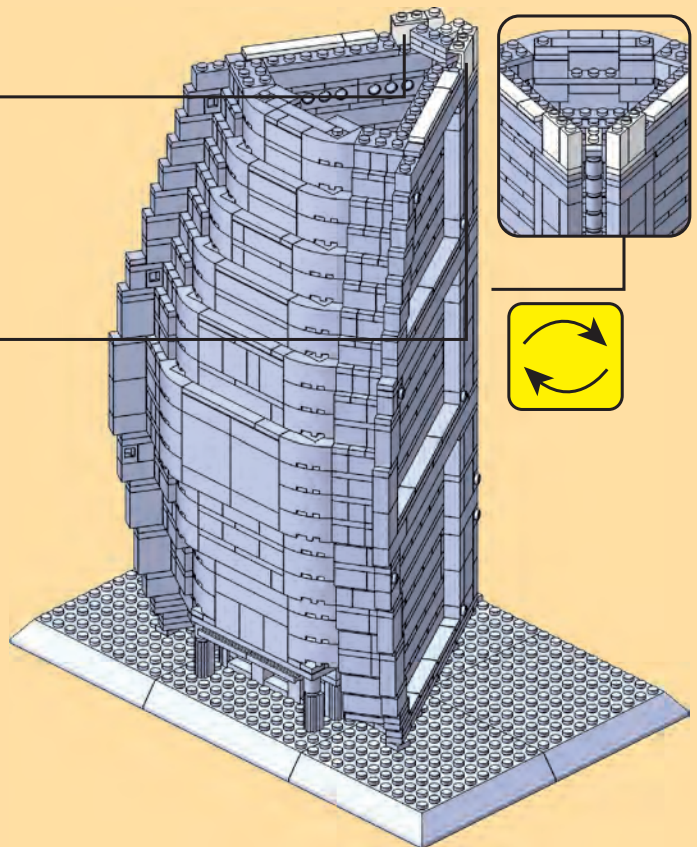
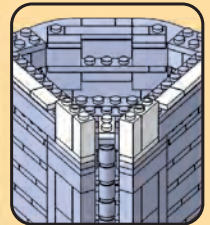
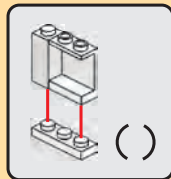
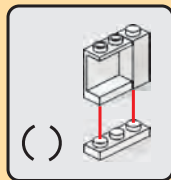

- X2
- X2
- X1
- X2
- X2
- X2





58

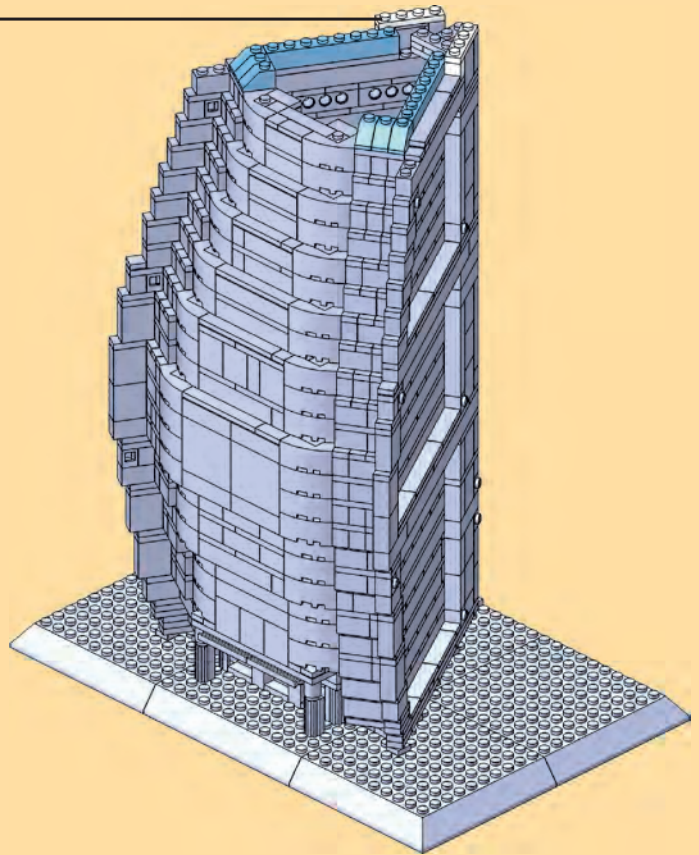
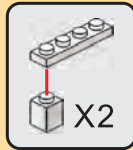

-  X2
-  X2
-  X6
-  X2

59

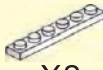

-  X2
-  X2
-  X2
-  X6
-  X2
-  X2

60

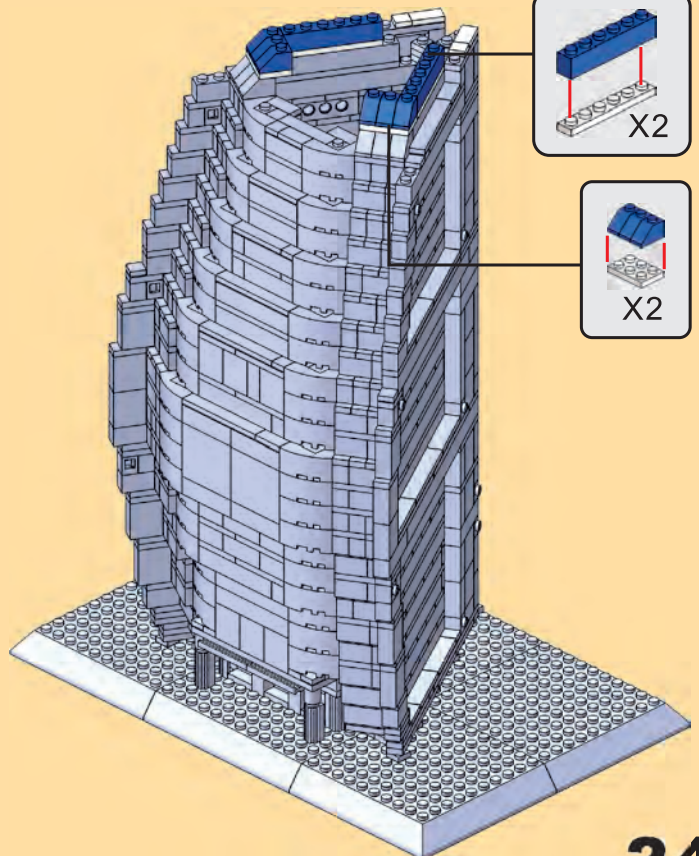
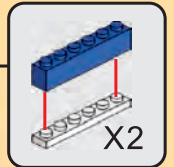

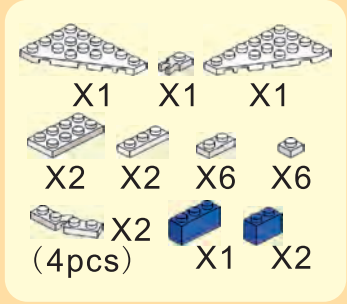



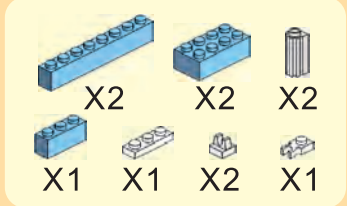
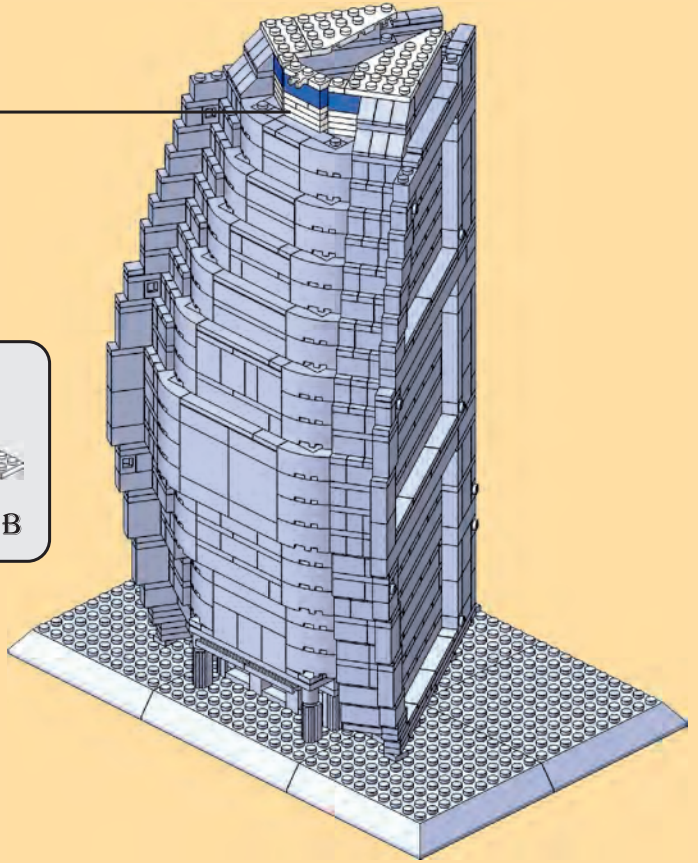
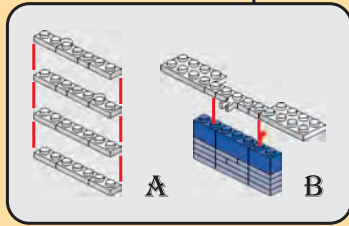



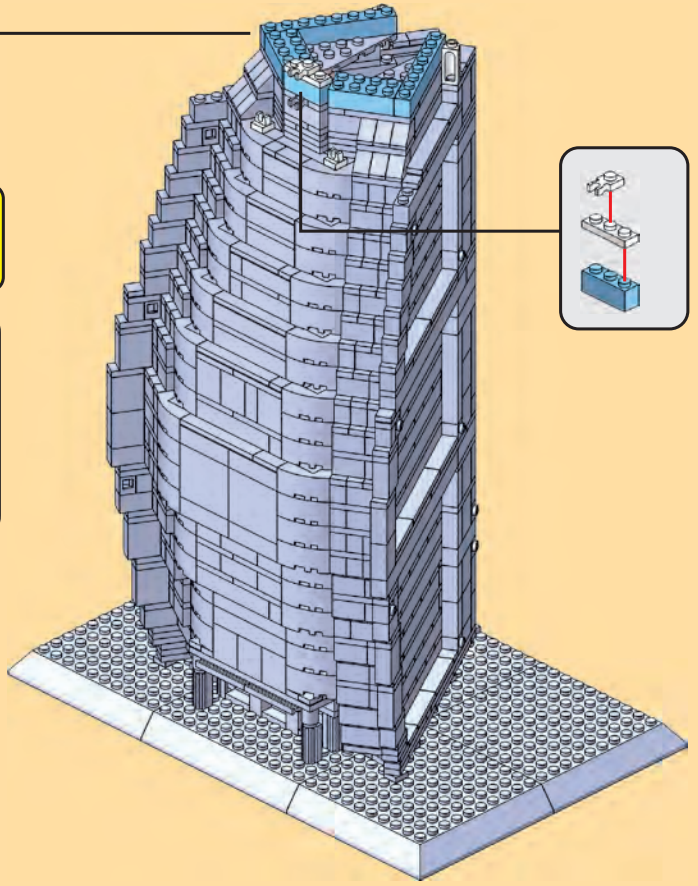
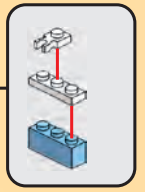
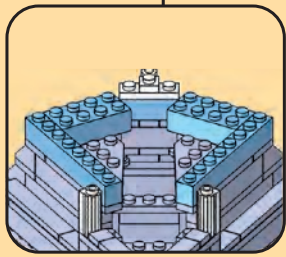

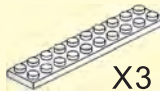





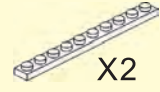



61









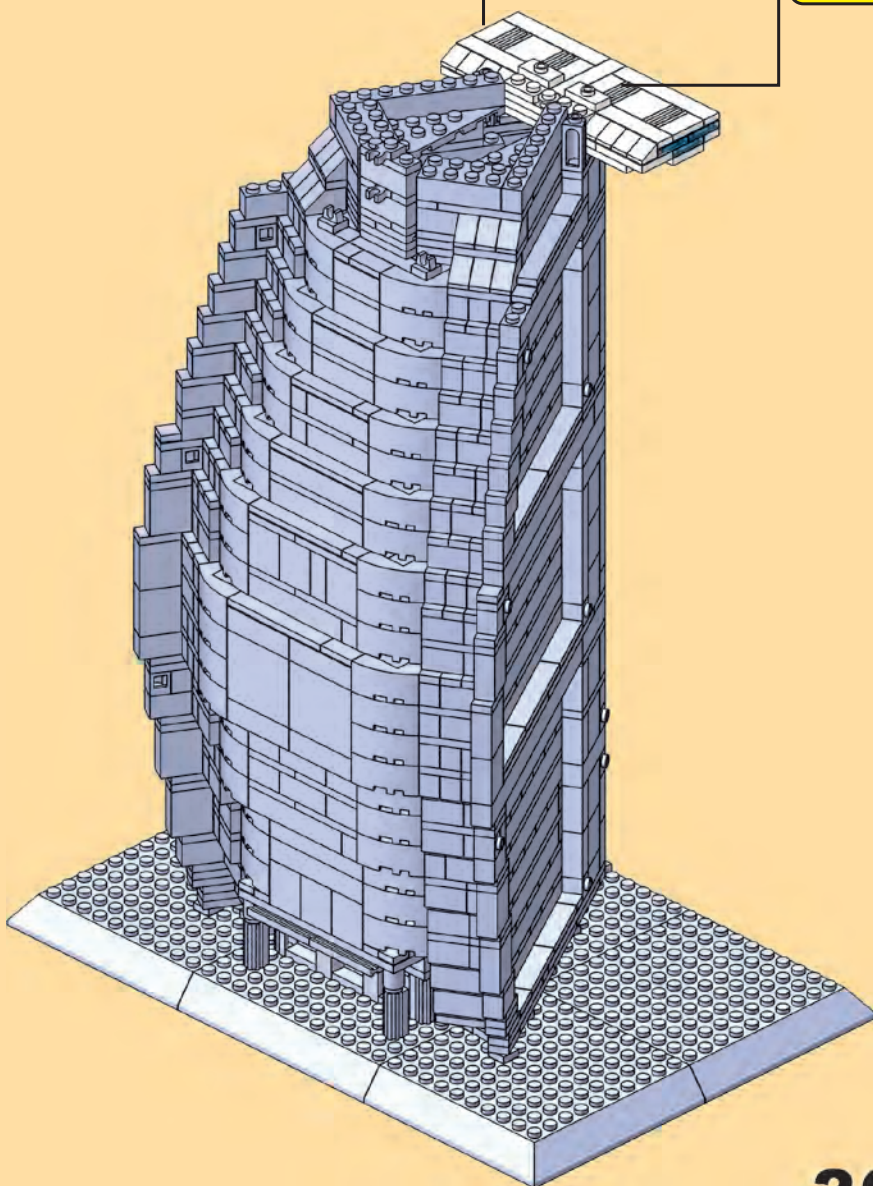
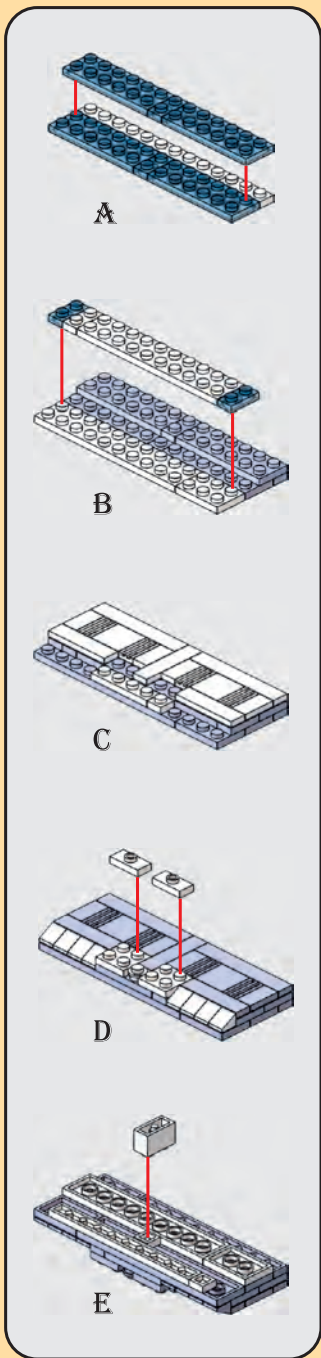
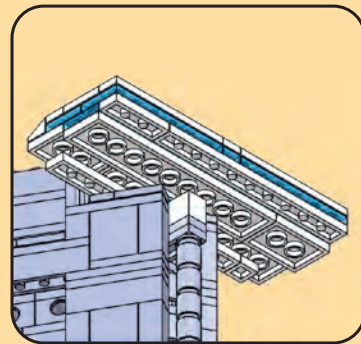

62



- X3  X2  X1  X1  X8  X4  X1 
- X2  X2  X2  X2  X1  X3 
- X4  X3  X1  X2  X4  X4 



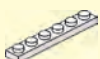





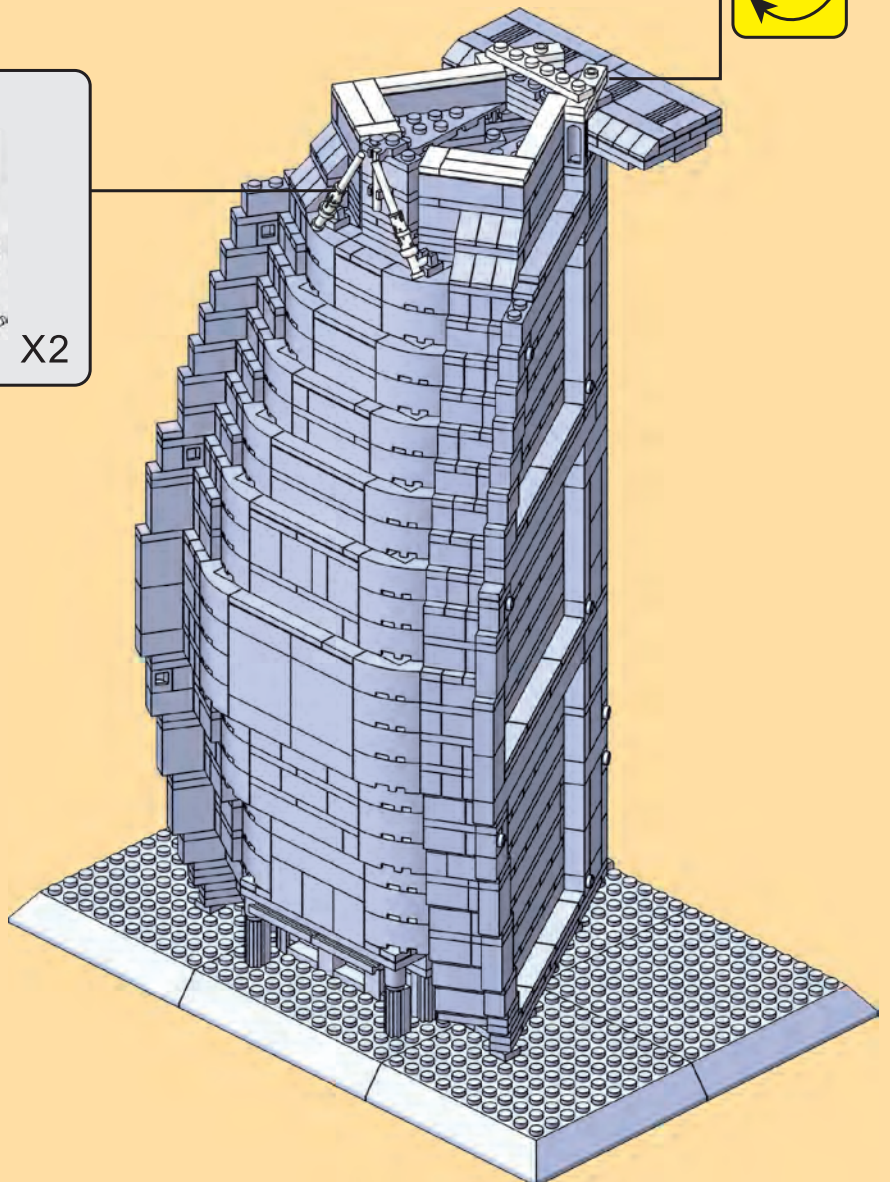
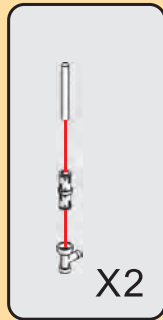
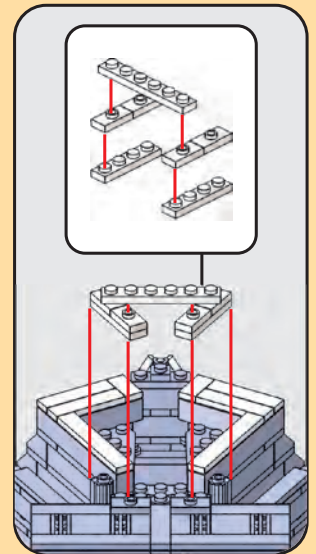

63



- | | | |
|--|--|--|
|  X2 |  X4 |  X2 |
|  X2 |  X4 |  X2 |
|  X1 |  X2 |  X3 |

64



-  X1
-  X2
-  X2
-  X6
-  X2
-  X2
-  X1
-  X3
-  X1
-  X15

65

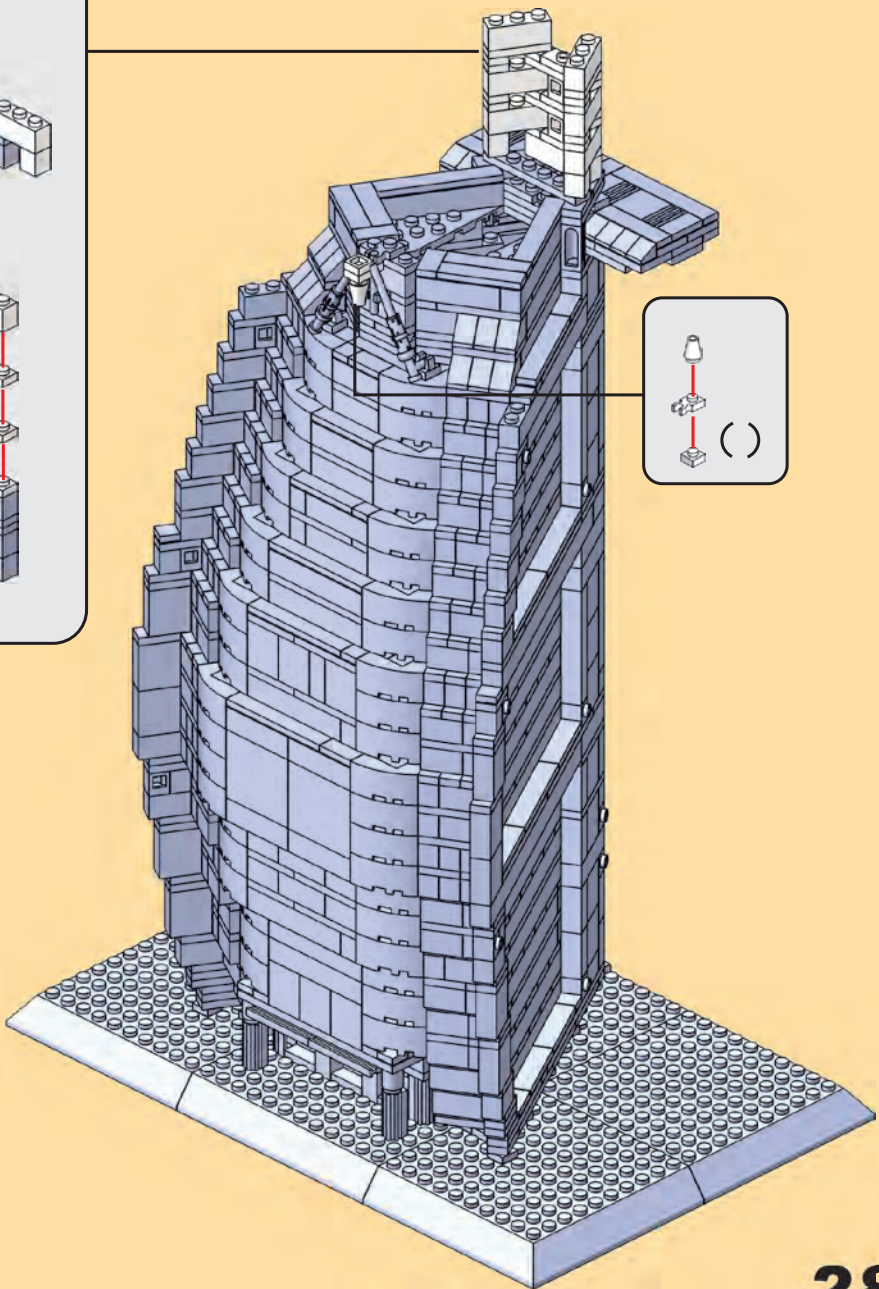
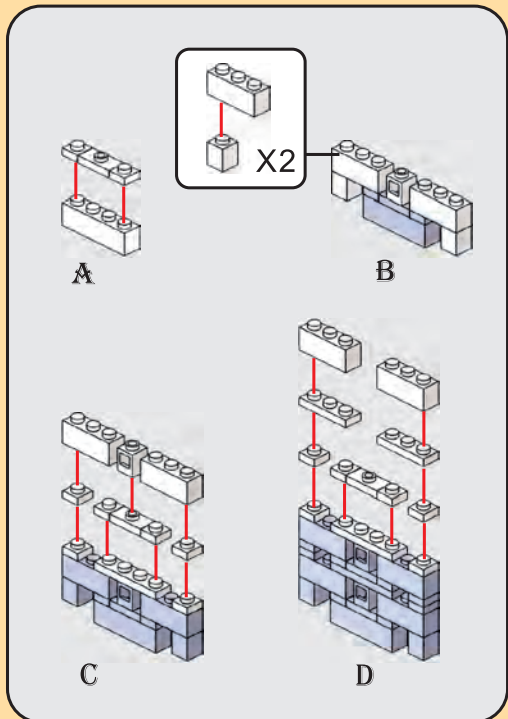

- X30
- X30
- X2
- X2
- X22
- X2
- X2

66

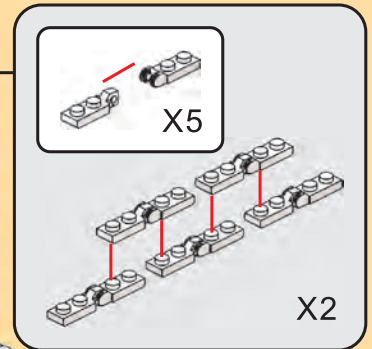
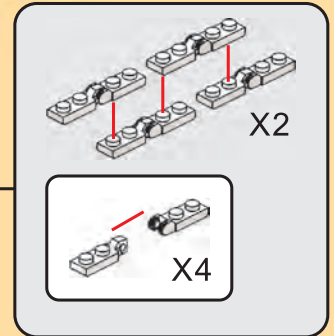
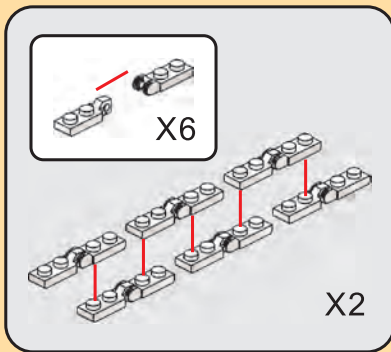
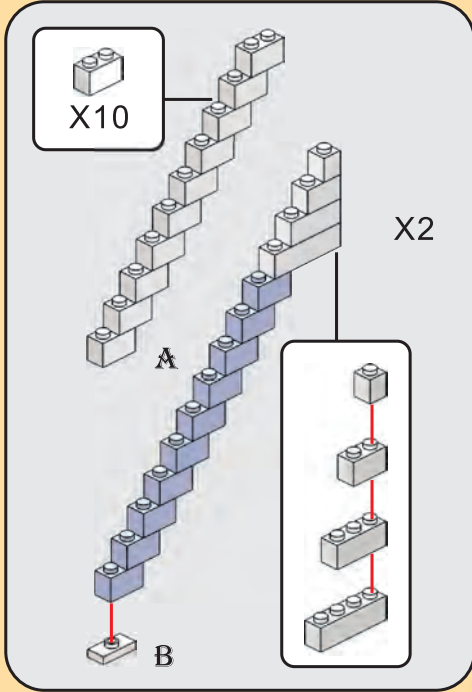
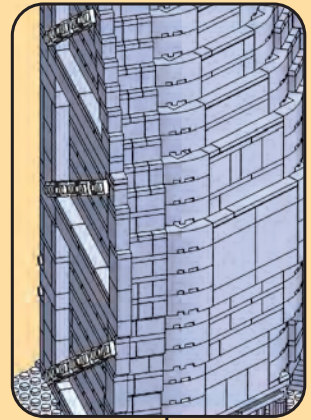



X2



X1 (4pcs)



X1



X1



X1 (2pcs)



X1

67

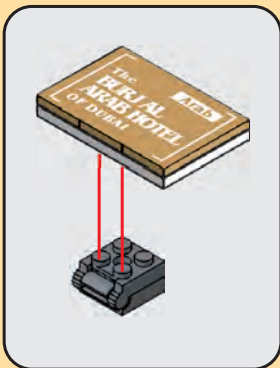
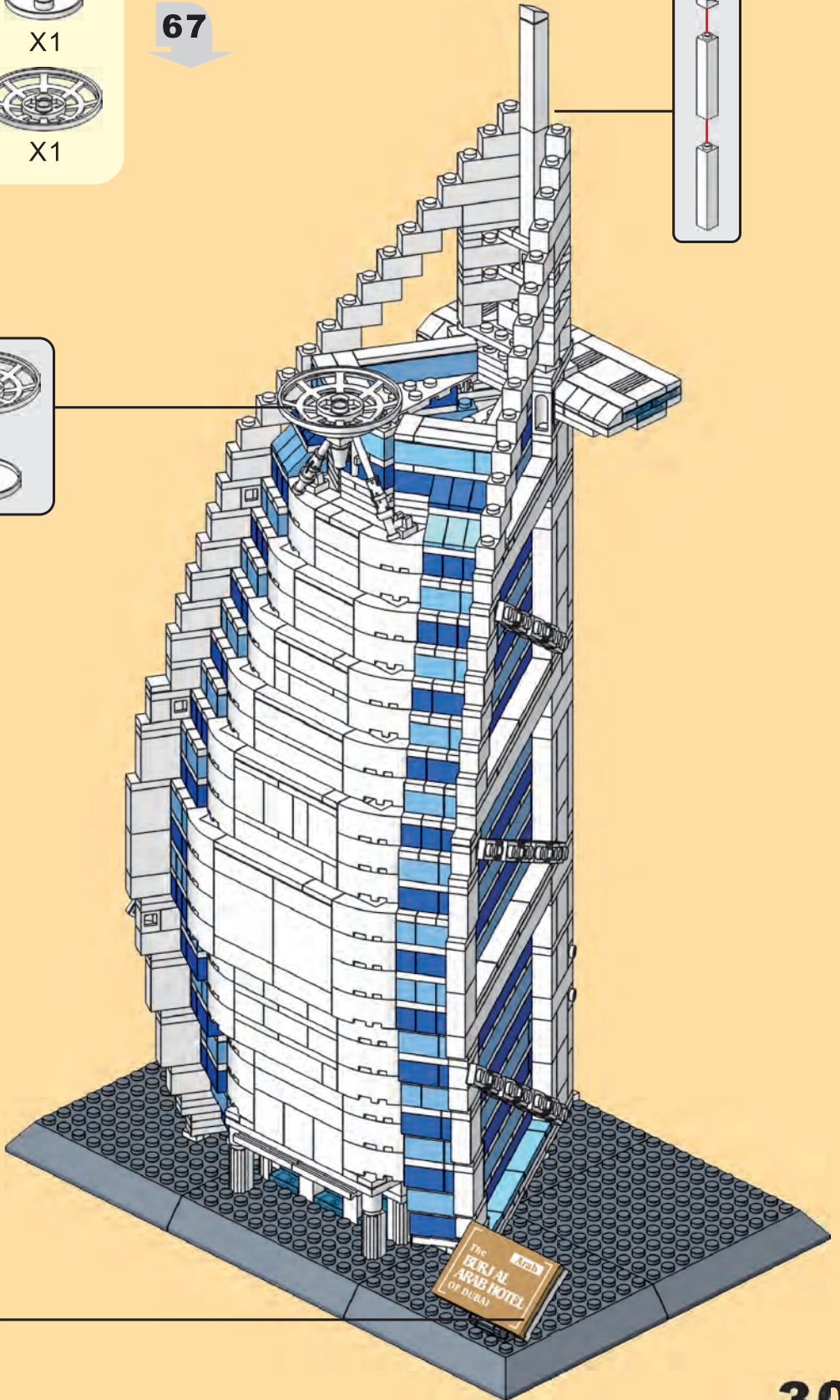
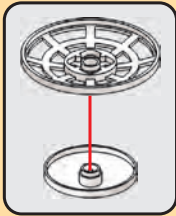
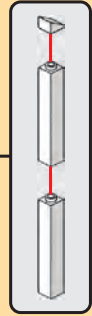



THE BURJ AL ARAB HOTEL OF DUBAÏ

L'HÔTEL BURJ AL ARAB DE DUBAÏ

INTRODUCTION

The Burj Al Arab is a luxury hotel located in Dubai, United Arab Emirates. It is the third tallest hotel in the world (although 39% of its total height is made up of non-occupiable space). Burj Al Arab stands on an artificial island 280 m (920 ft) from Jumeirah beach and is connected to the mainland by a private curving bridge. The shape of the structure is designed to resemble the sail of a ship. It has a helipad near the roof at a height of 210 m (689 ft) above ground. Burj Al Arab was designed by multidisciplinary consultancy Atkins, led by architect Tom Wright, who has since become co-founder of WKK Architects. The design and construction were managed by Canadian engineer Rick Gregory also of WS Atkins. It's very similar to the Vasco da Gama Tower, located in Lisbon, Portugal. Construction of the Island began in 1994 and involved up to 2,000 construction workers during peak construction. It was built to resemble the billowing spinnaker sail of a J-class yacht. "Wings" spread in a V to form a vast "mast", in the space between them is enclosed in a massive atrium. The architect Tom Wright said "The client wanted a building that would become an iconic or symbolic statement for Dubai; this is very similar to Sydney with its Opera House, London with Big Ben, or Paris with the Eiffel Tower. It needed to be a building that would become synonymous with the name of the country." The building opened in December 1999.

L'Hôtel Burj Al Arab est un hôtel de luxe situé à Dubaï, Émirats Arabes Unis. Il est le troisième plus haut hôtel au monde (bien que 39 % de sa hauteur totale soit conçue d'espace non occupable). Le Burj Al Arab est situé sur une île artificielle de 280 m (920 pi.) de la plage de Jumeirah et est connecté au continent par un pont courbe. La forme de la structure a été conçue pour ressembler à un voile de bateau. Il a une hélicoptère près du toit à une hauteur de 210 m (689 pi.) au-dessus du sol. Le Burj Al Arab a été conçu par la firme de consultants multidisciplinaires Atkins, dirigée par l'architecte Tom Wright, qui est depuis devenu le cofondateur de WKK Architectes. La conception et la construction furent supervisés par l'ingénieur canadien Rick Gregory et aussi par WS Atkins. Il est très similaire à la tour Vasco de Gama, située à Lisbonne, Portugal. La construction de l'île commença en 1994 et durant la période de pointe de la construction, jusqu'à 2000 ouvriers du bâtiment furent impliqués. Il a été construit pour ressembler à la voile spinnaker gonflée d'un yacht de classe J. Des « ailes » épandent en forme de V pour former un vaste « mât », un atrium massif est situé dans l'espace entre eux. L'architecte Tom Wright a dit : « Le client voulait un immeuble qui deviendrait un symbole iconique pour Dubaï, comme Sydney et la maison de l'opéra, Londres et Big Ben ou Paris et la tour Eiffel. Il devait être un immeuble qui deviendrait synonyme avec le nom du pays. » L'immeuble fut ouvert en décembre 1999.

ALSO AVAILABLE: AUSSI DISPONIBLES:



EMPIRE STATE BUILDING



THE CN TOWER
LA TOUR DU CN



TAJ MAHAL



THE WHITE HOUSE
LA MAISON-BLANCHE



THE TOWER BRIDGE
TOWER BRIDGE



THE EIFFEL TOWER
LA TOUR EIFFEL



ELIZABETH TOWER
TOUR ELIZABETH



LEANING TOWER OF PISA
LA TOUR DE PISE

