



THE STATUE OF LIBERTY LA STATUE DE LA LIBERTÉ

America / États-Unis

The world's greatest architectural designs /

Les plus grandes œuvres architecturales du monde

6+

Creativity

Family Interaction

Observation

Reasoning

Fine motor skills



Créativité

Interaction familiale

Observation

Raisonnement

Motricité fine



1577 PCS

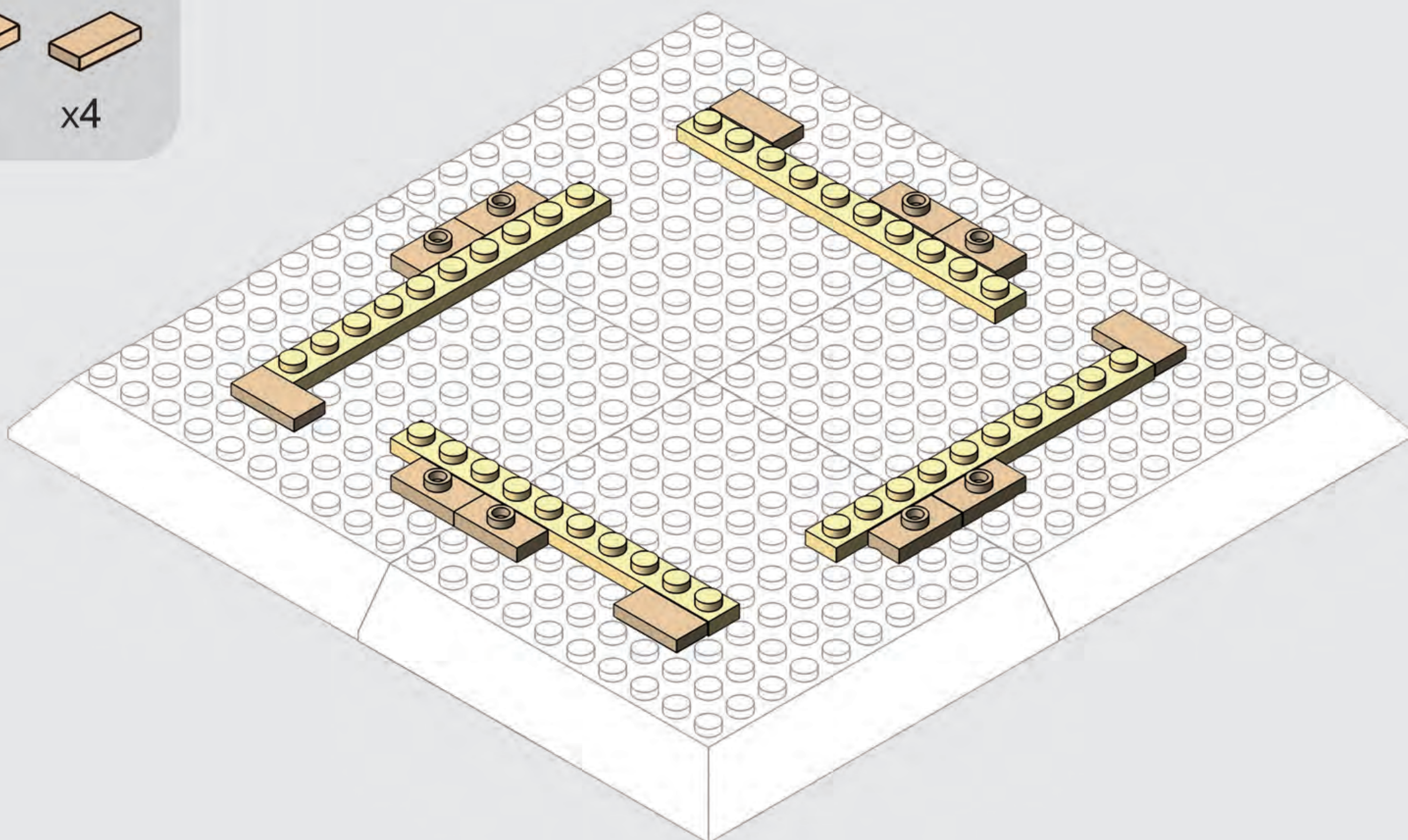
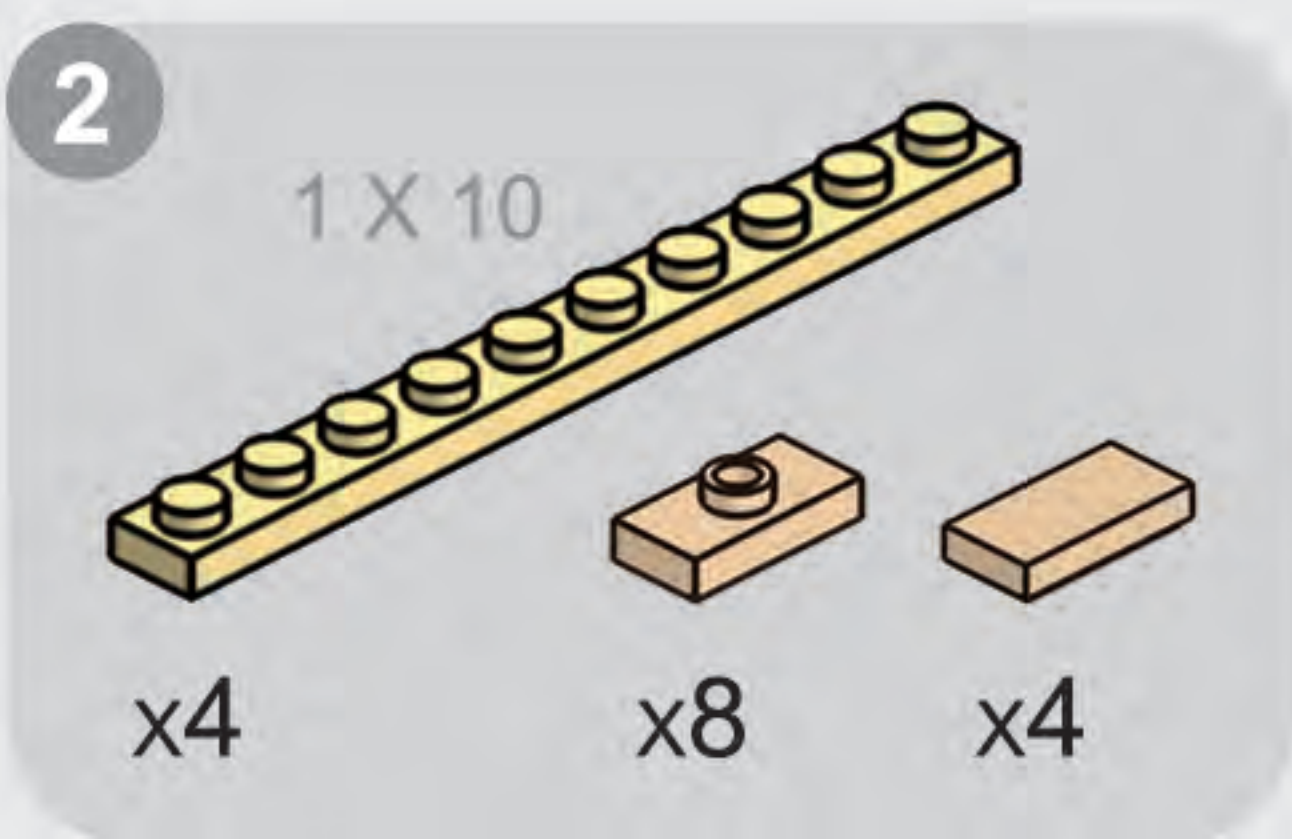
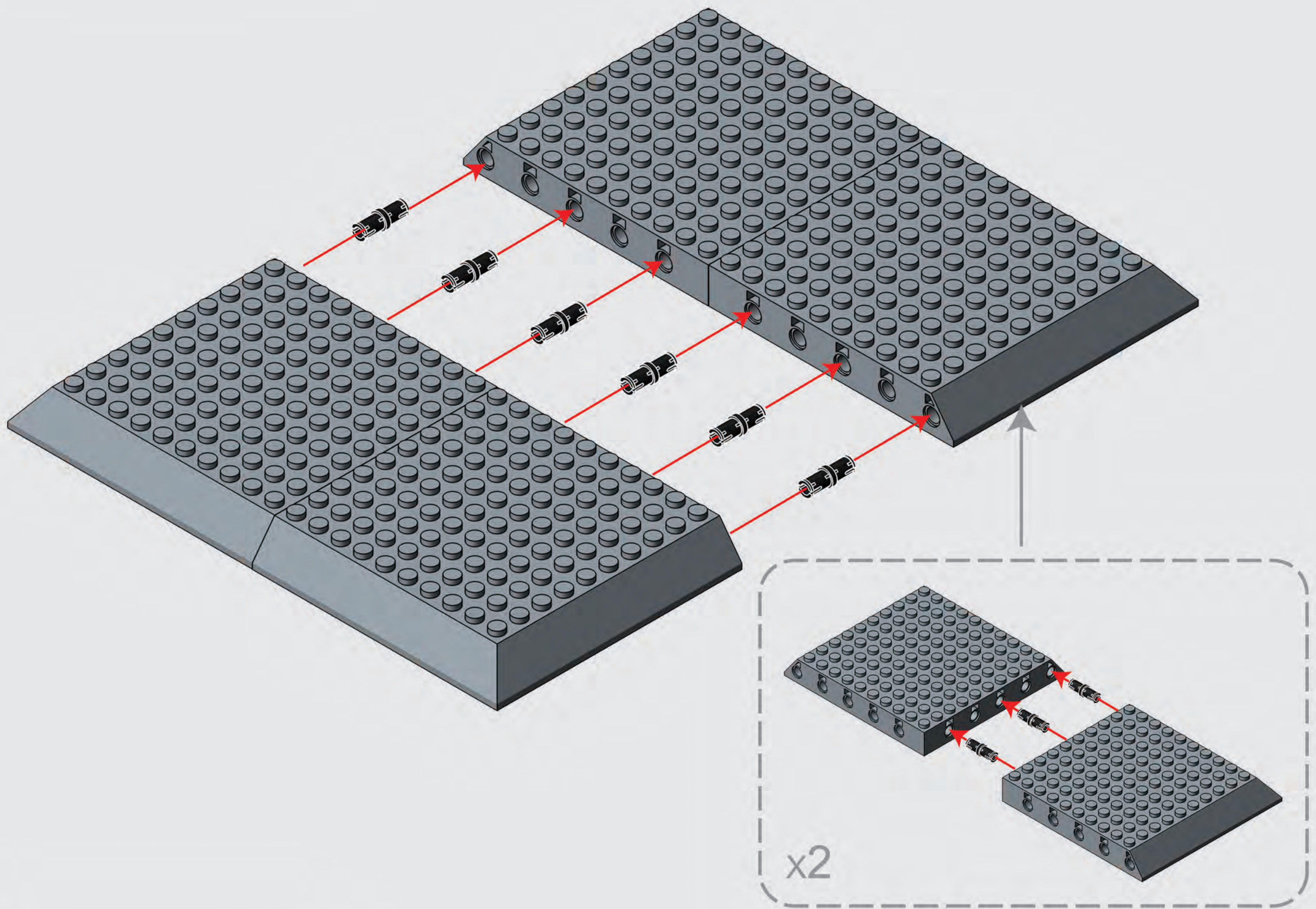
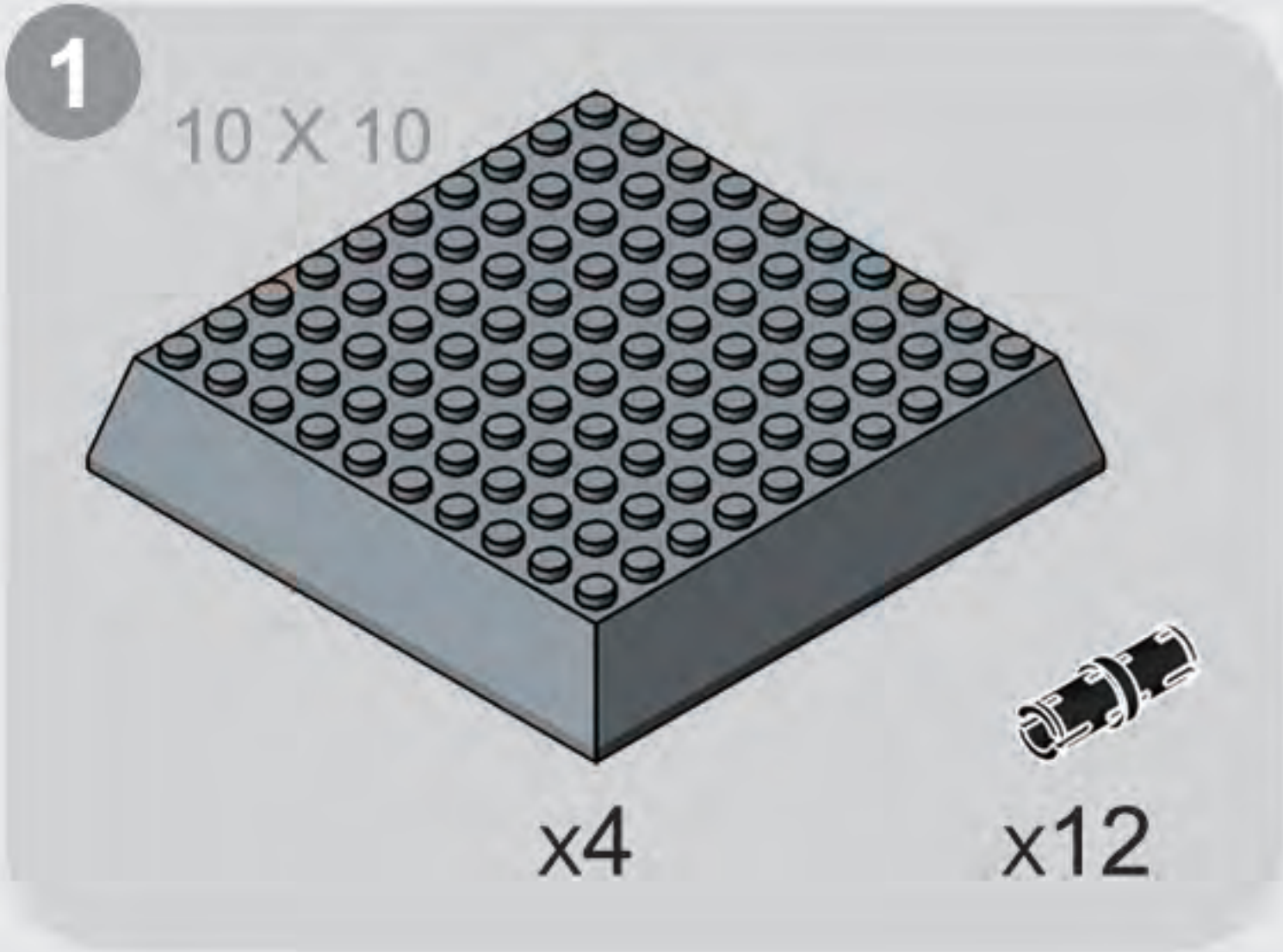

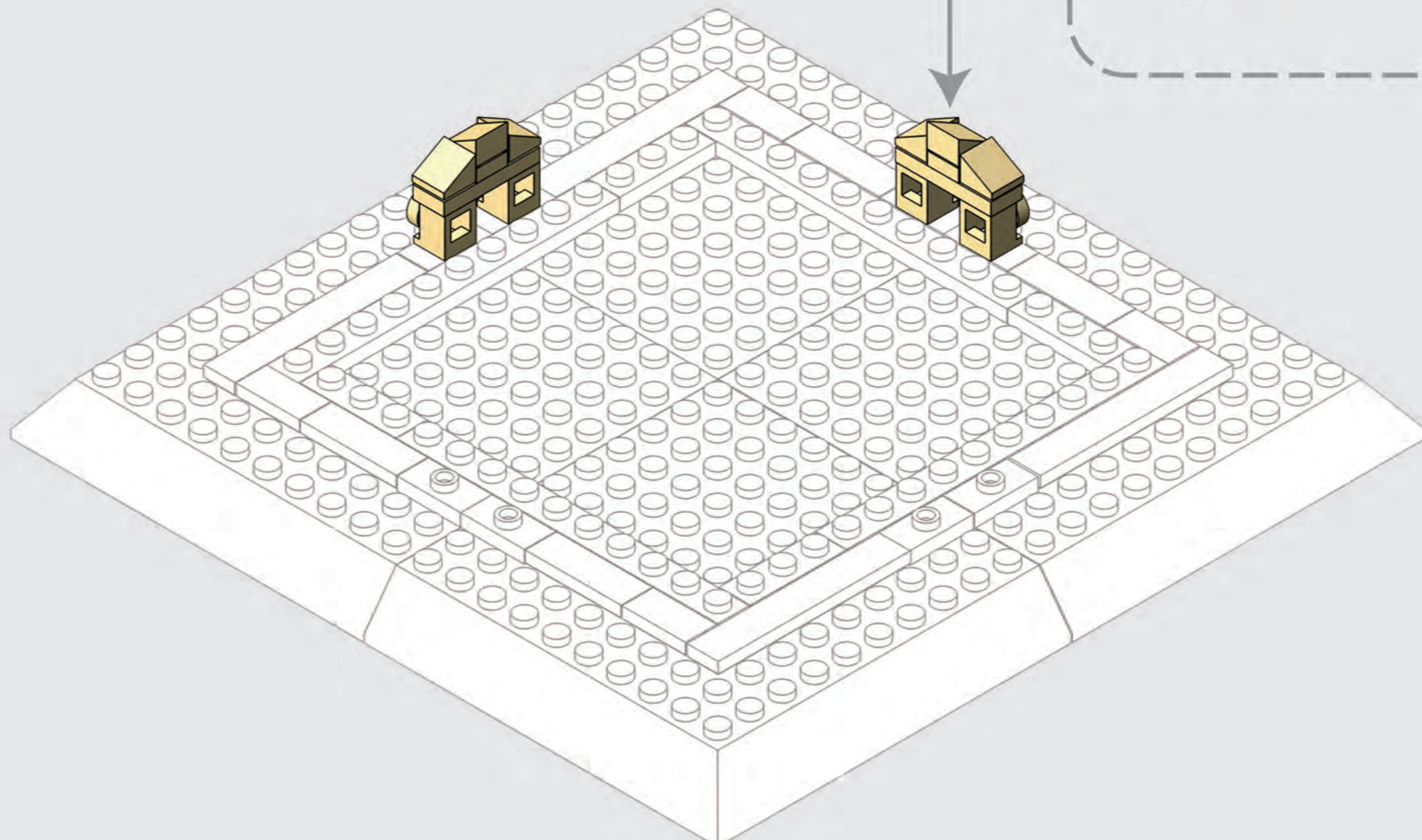
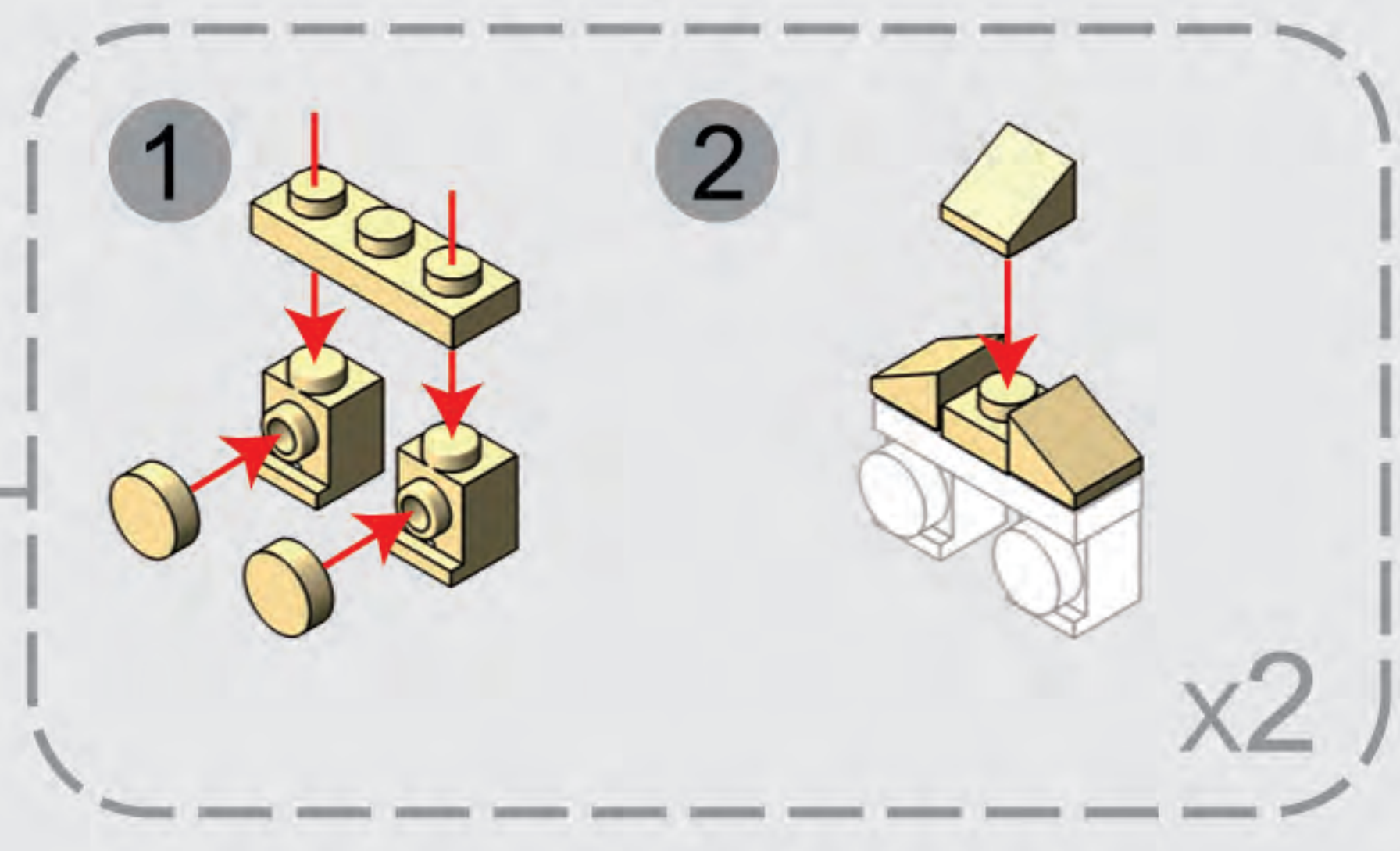
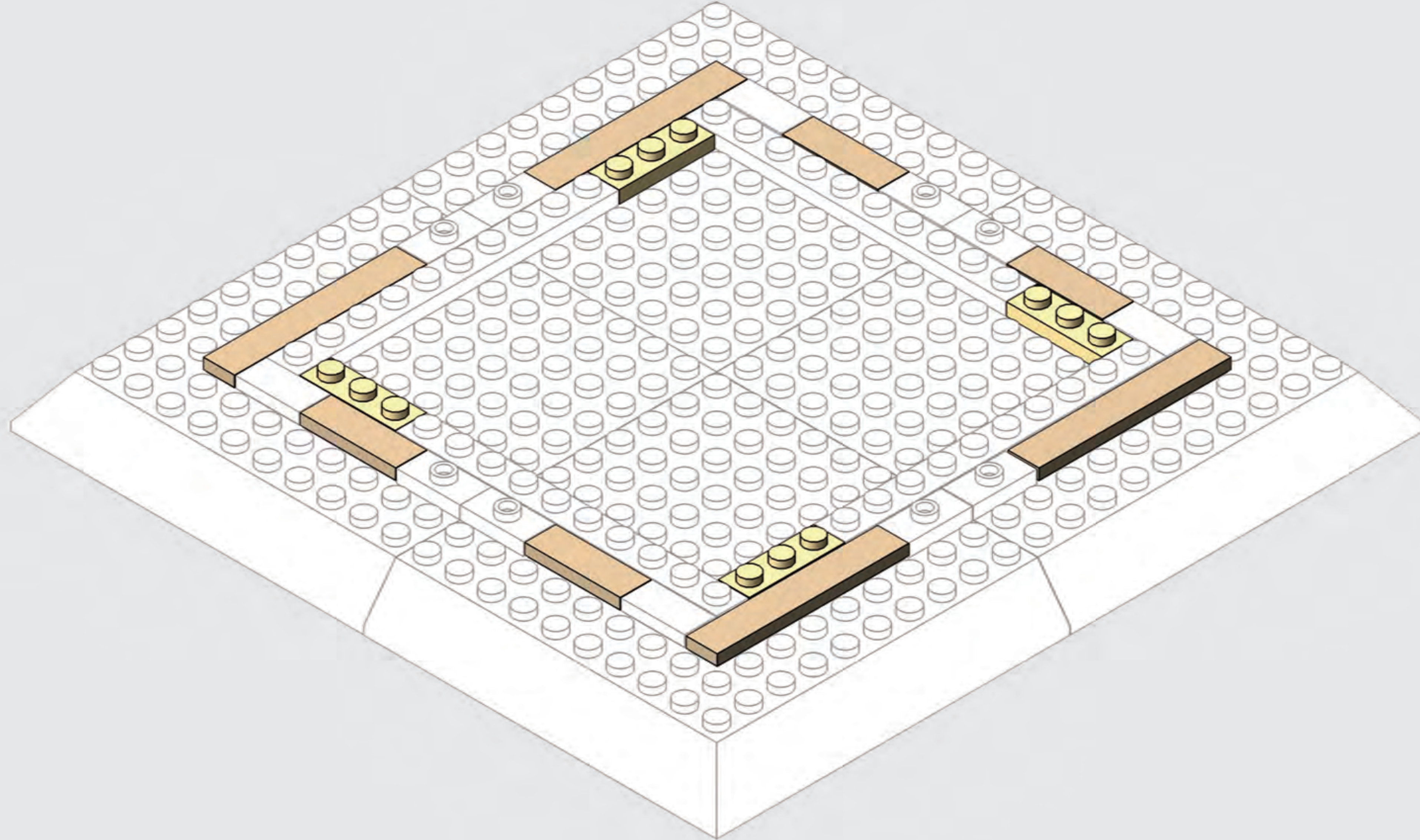
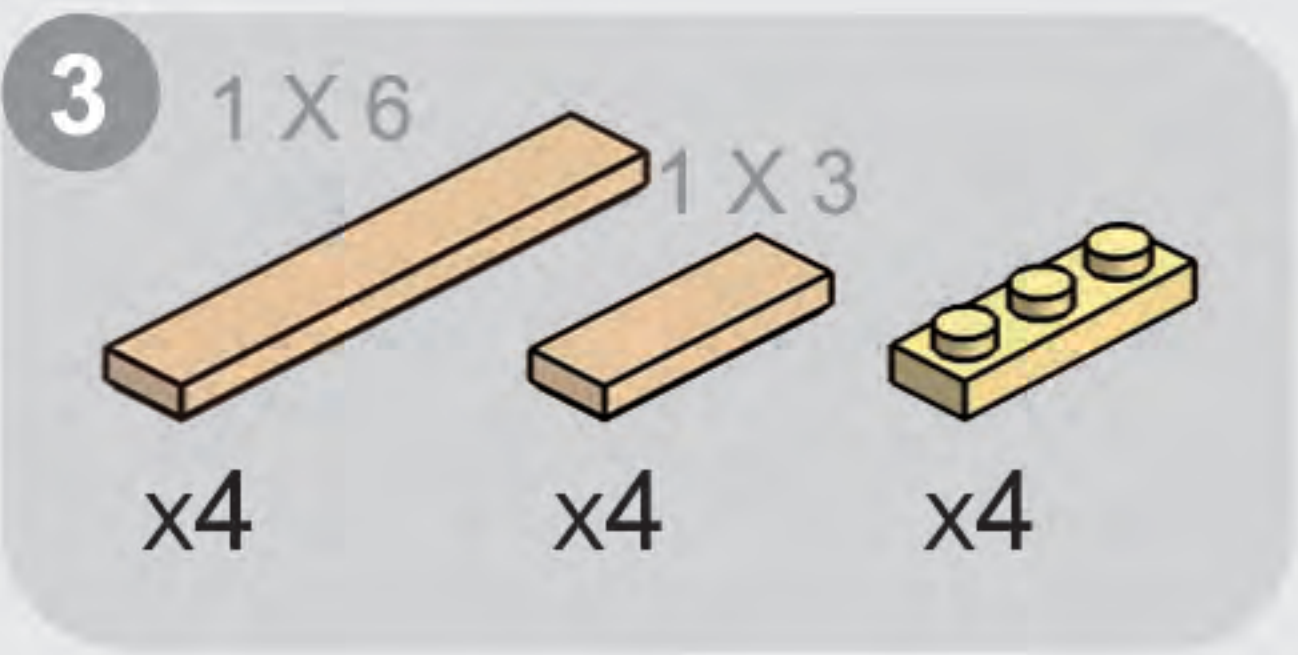

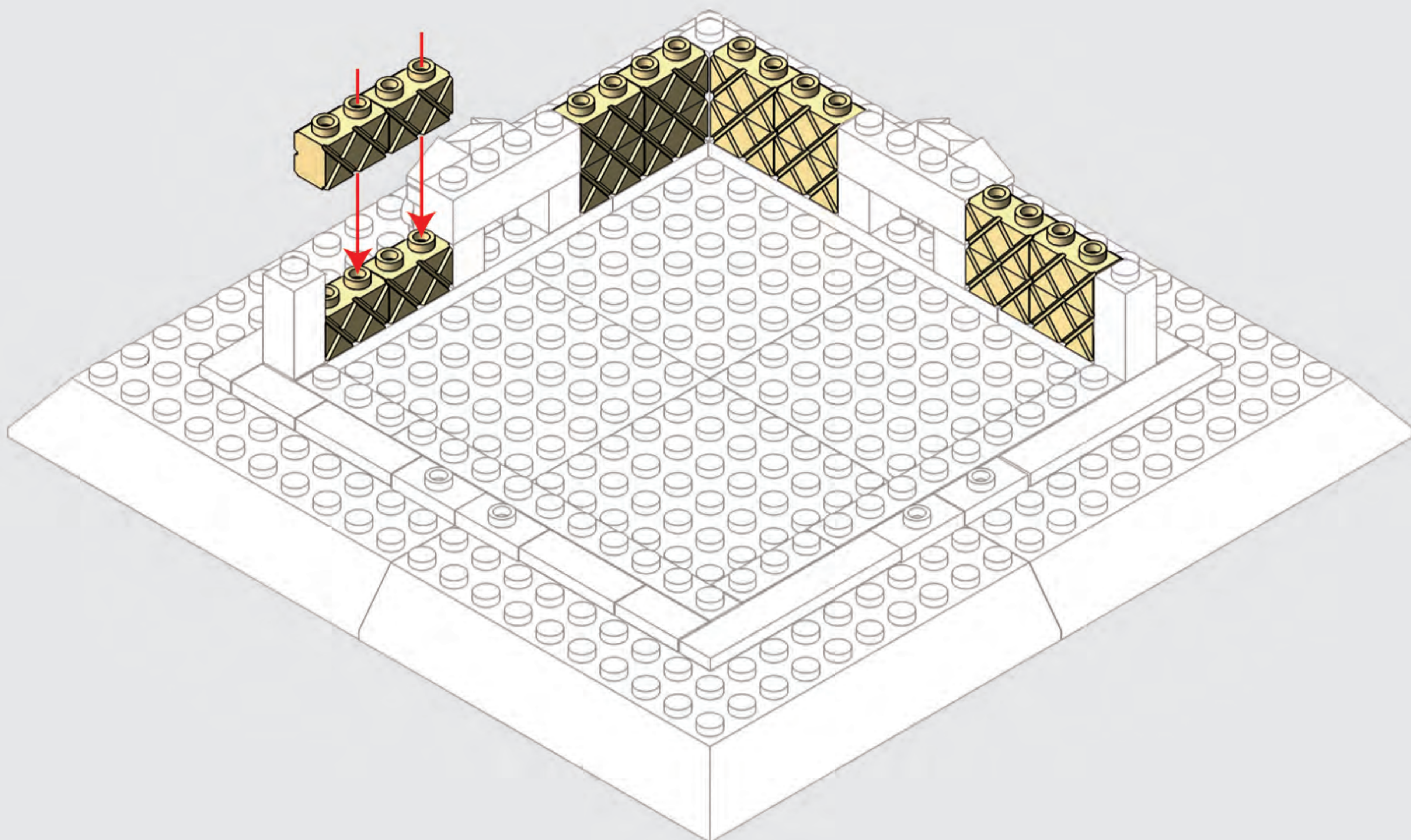
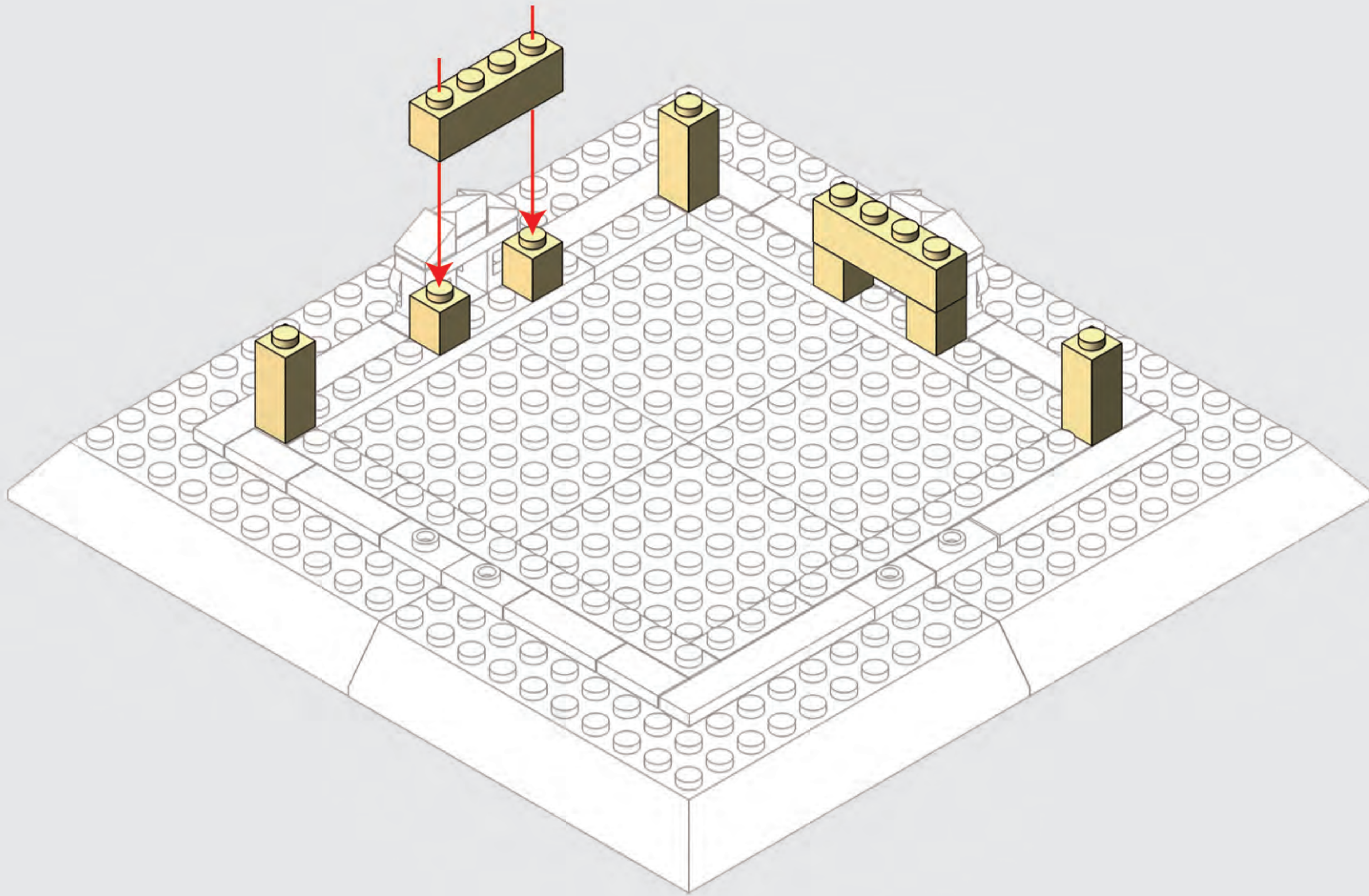
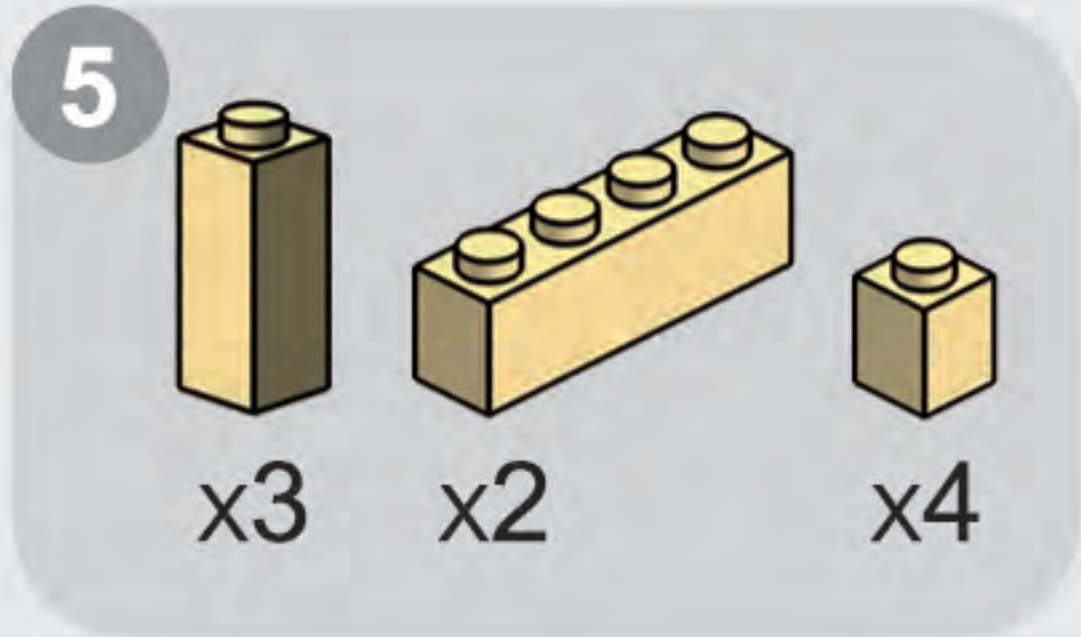

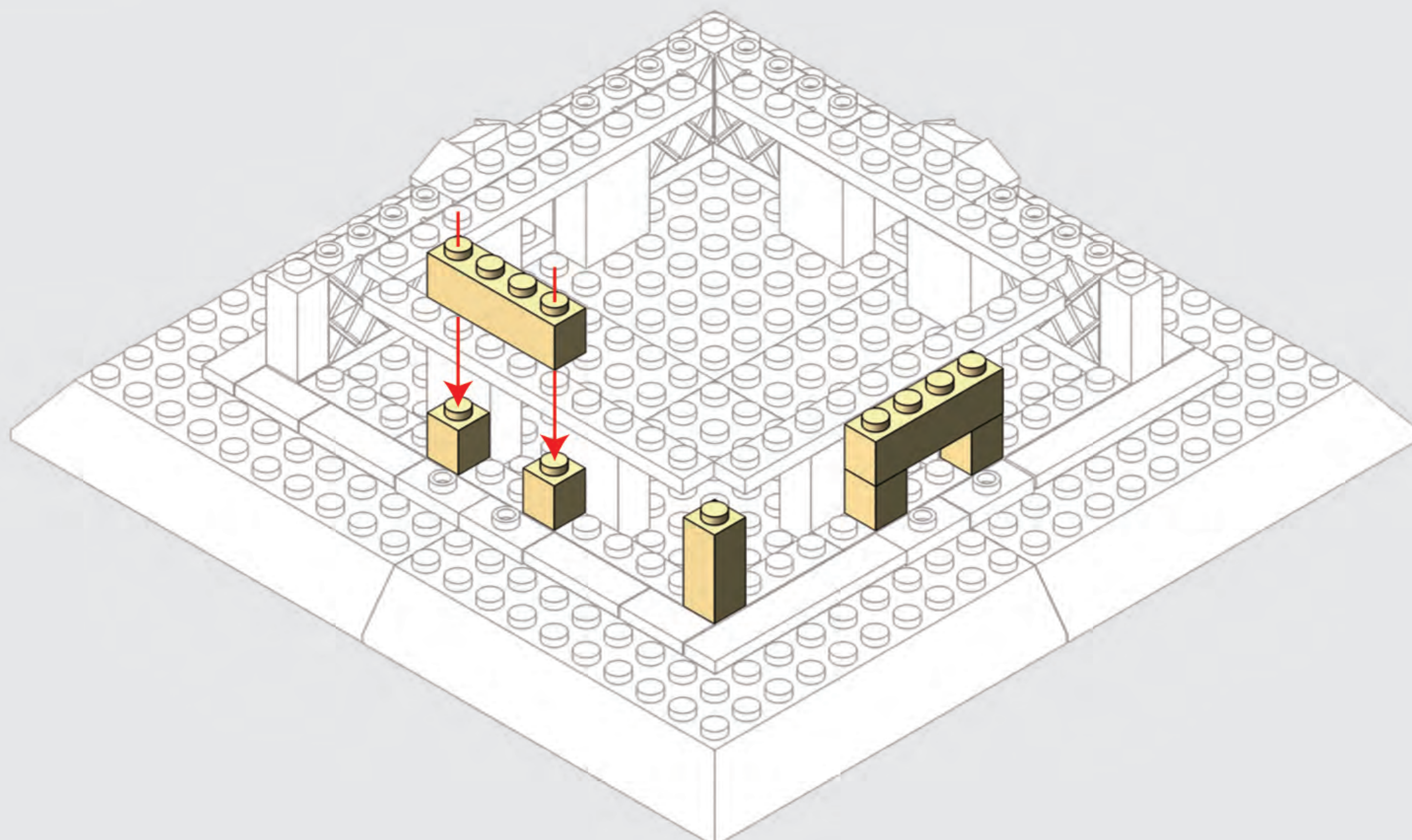
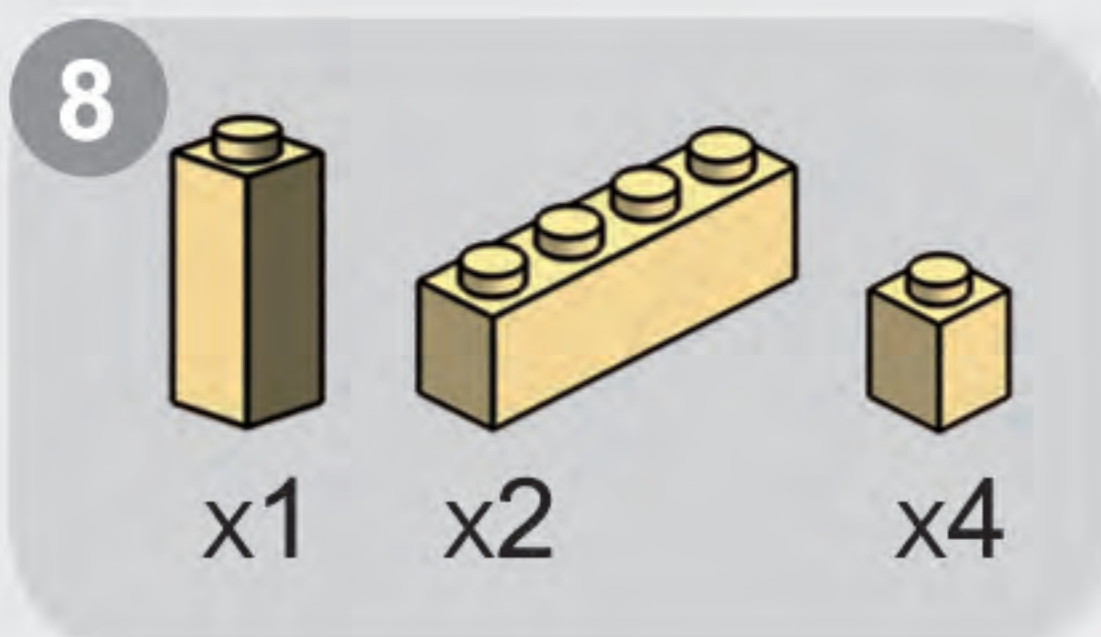
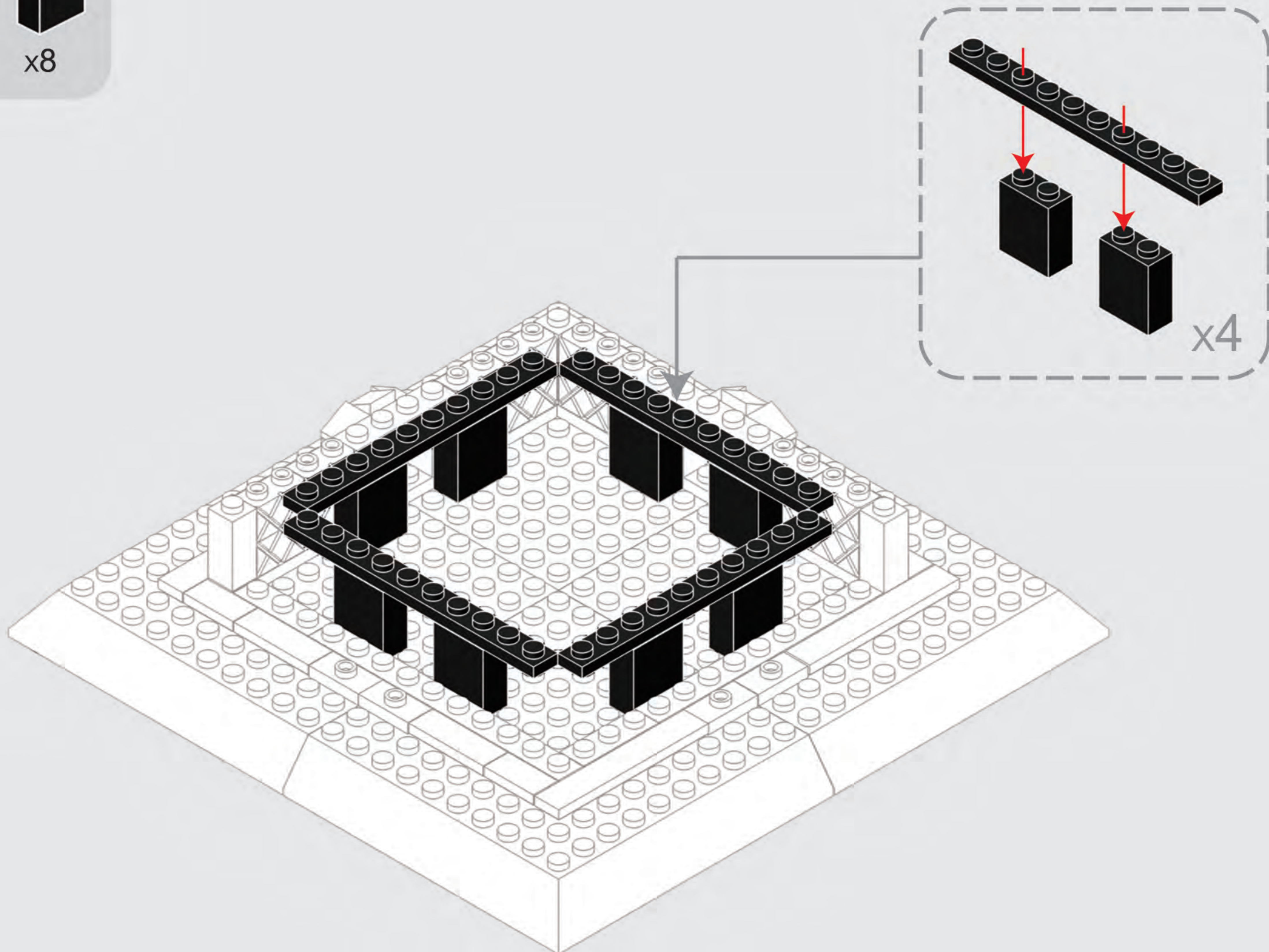
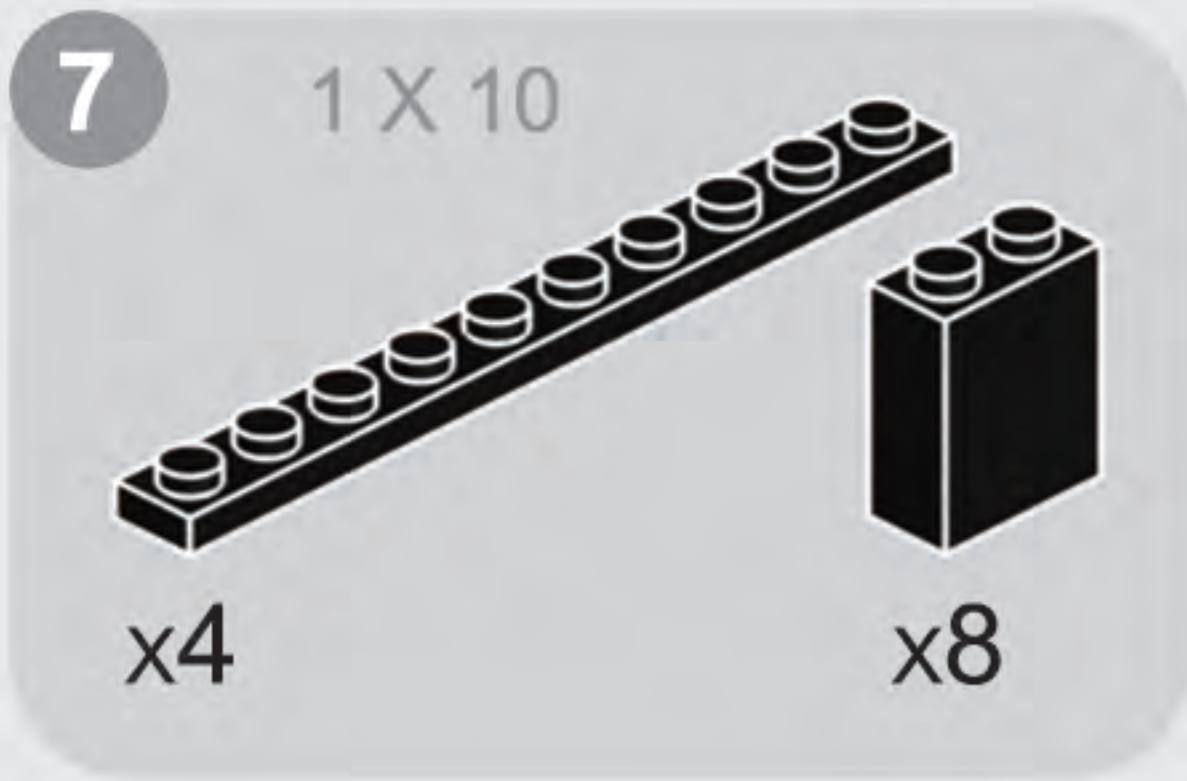

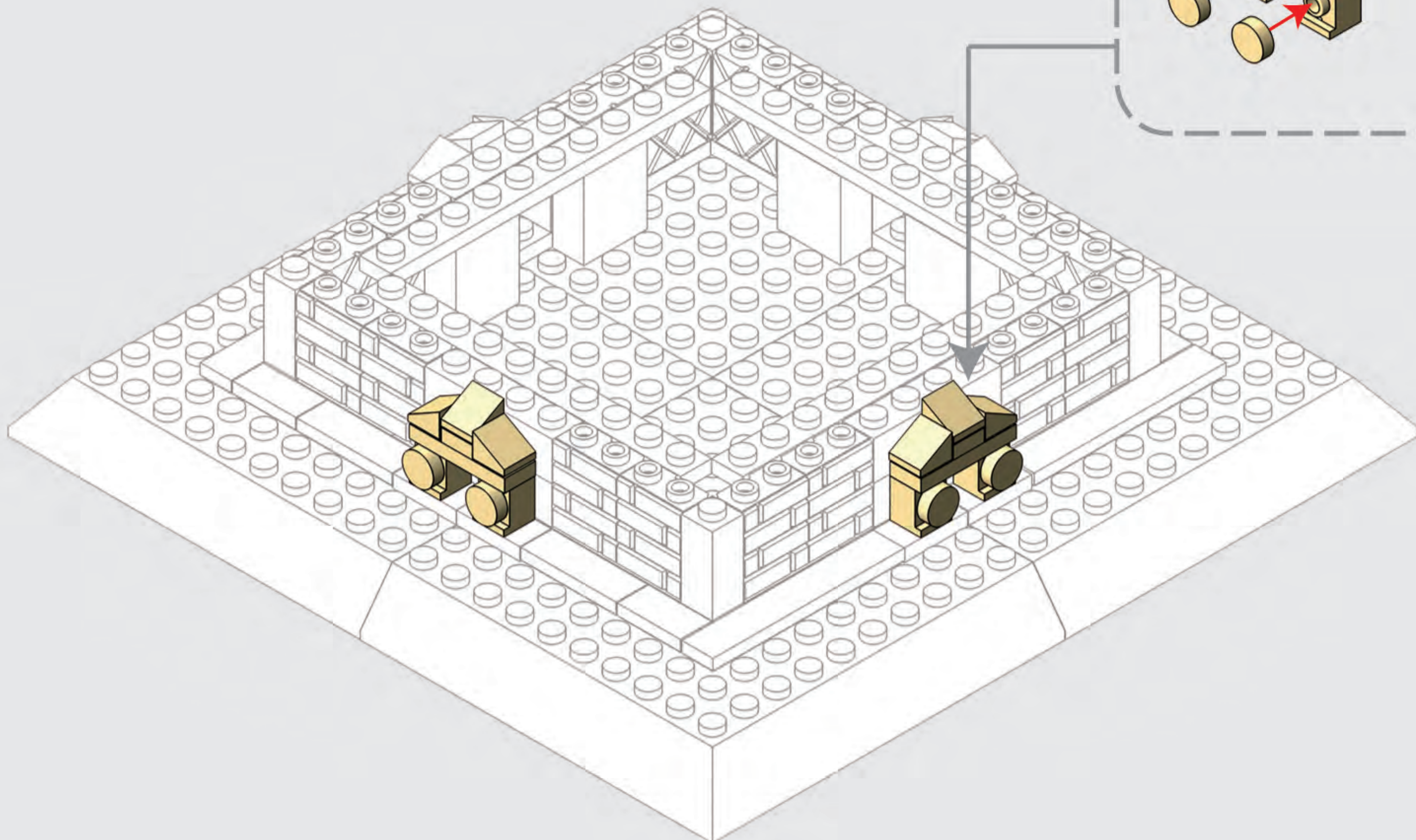
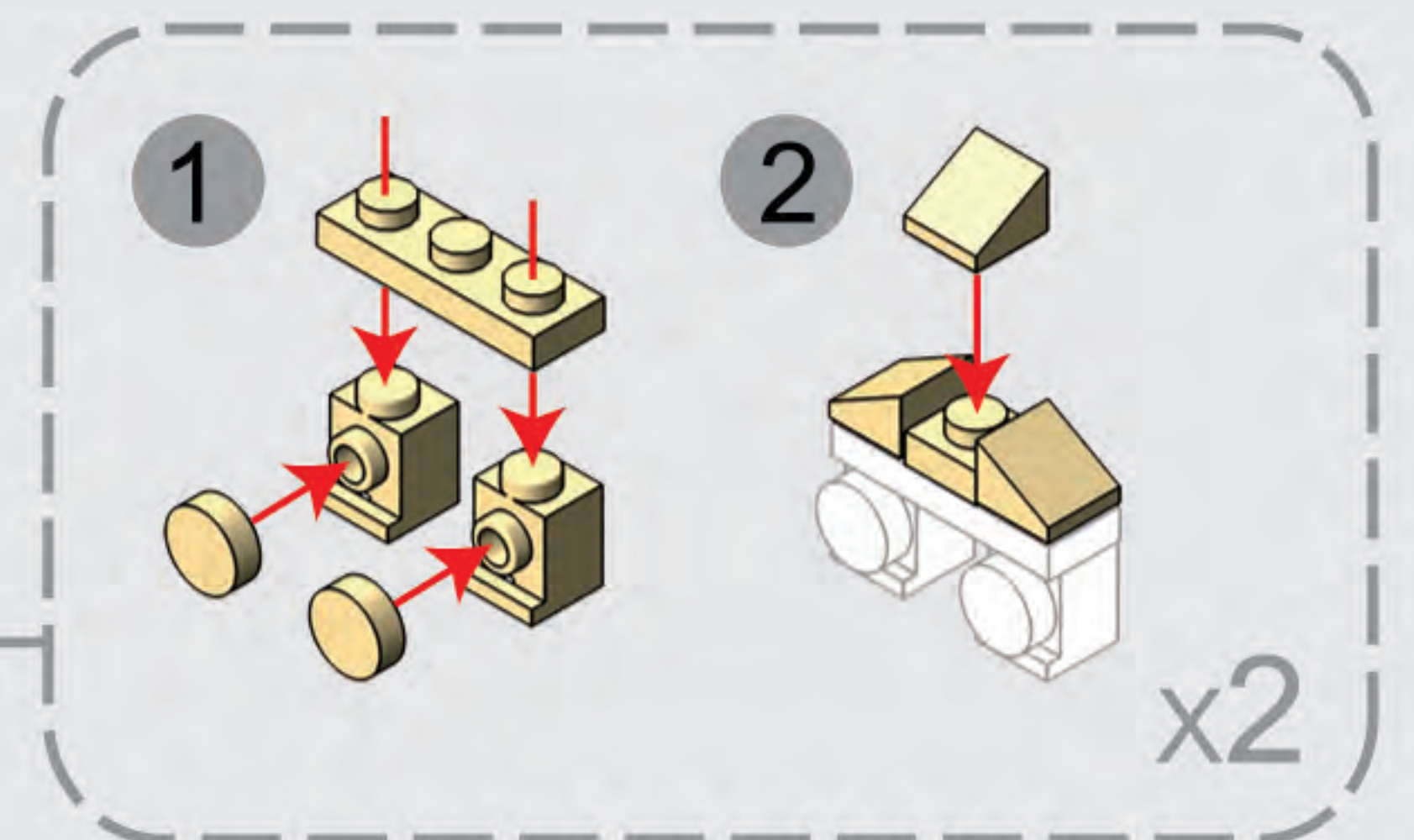
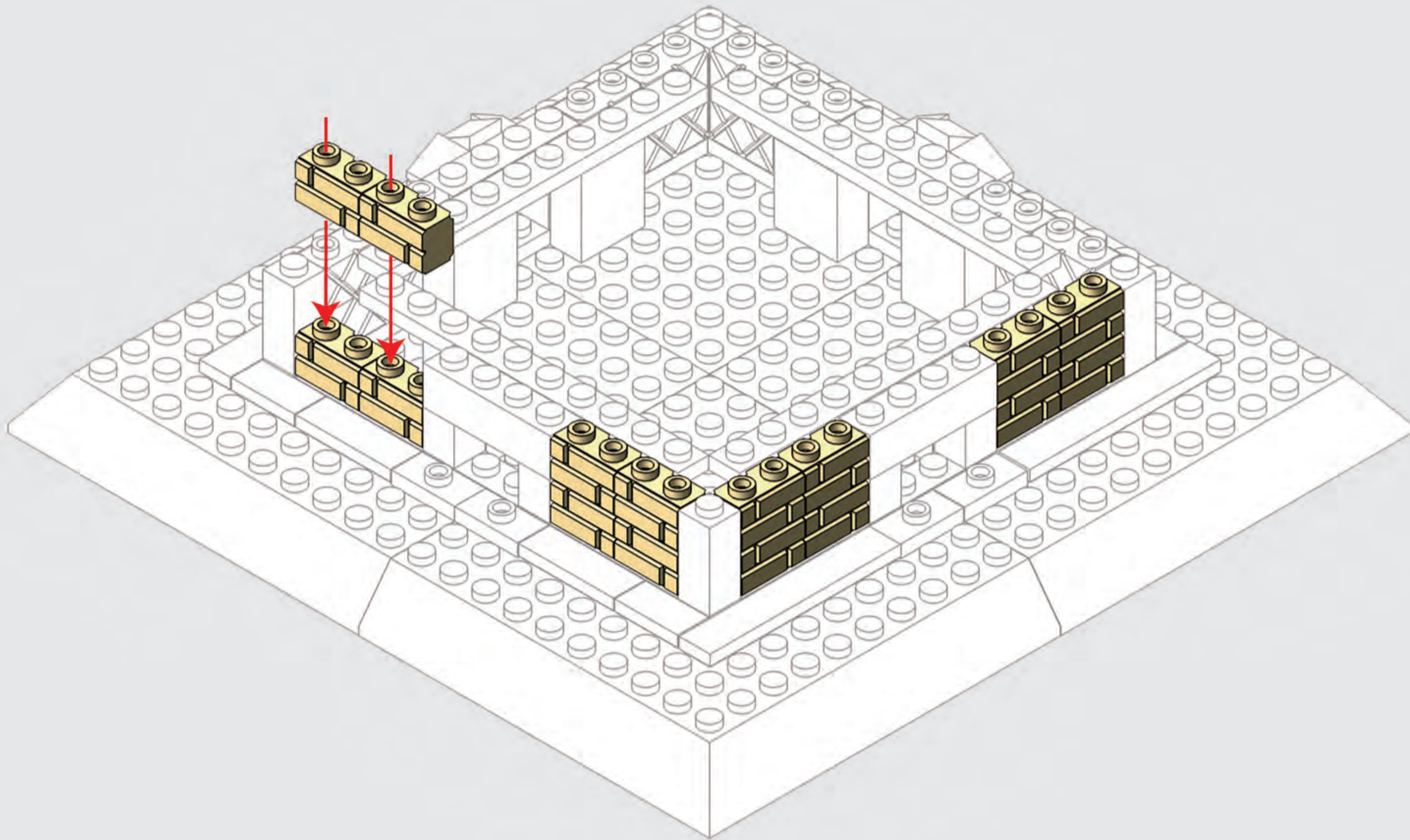

11

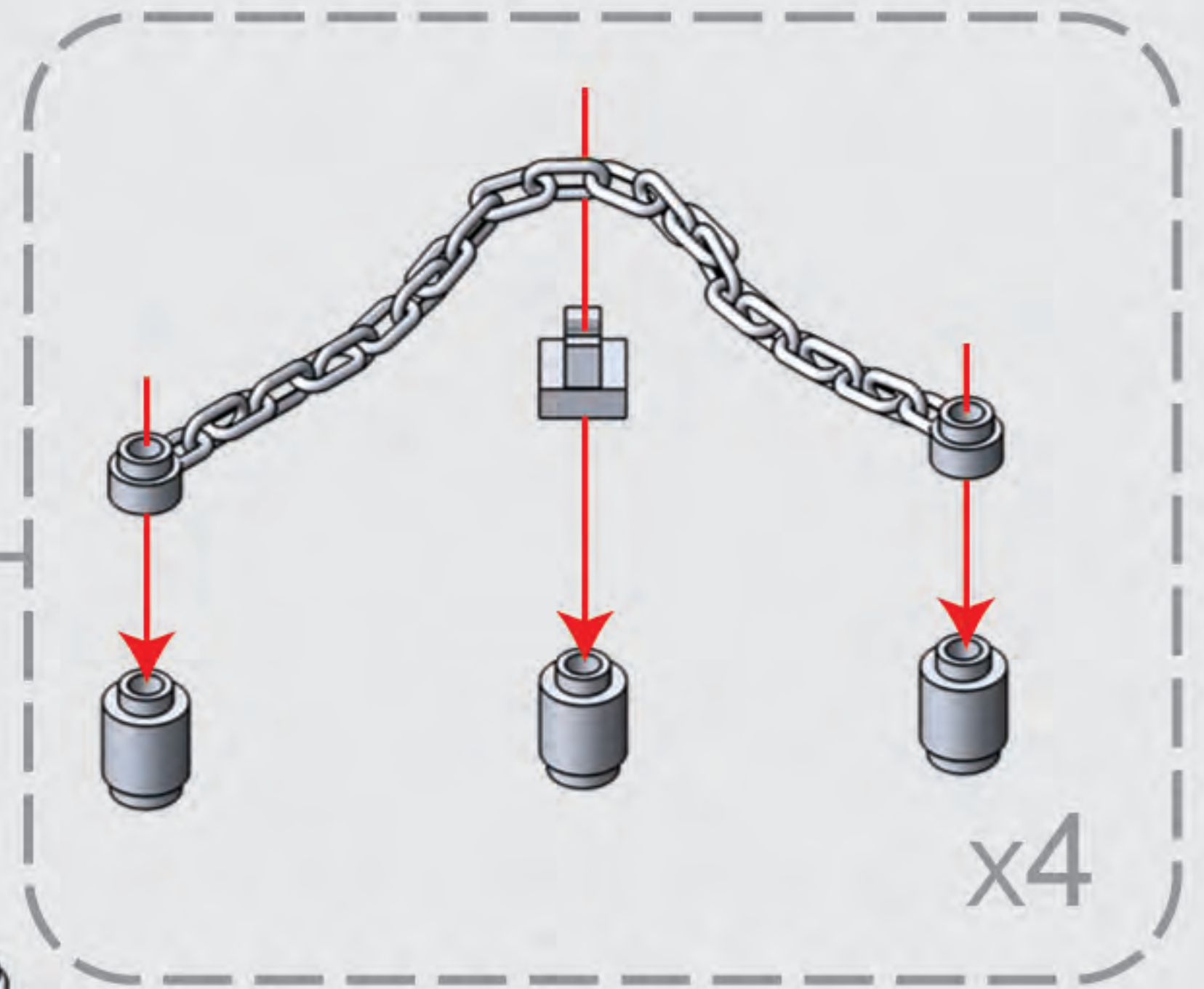
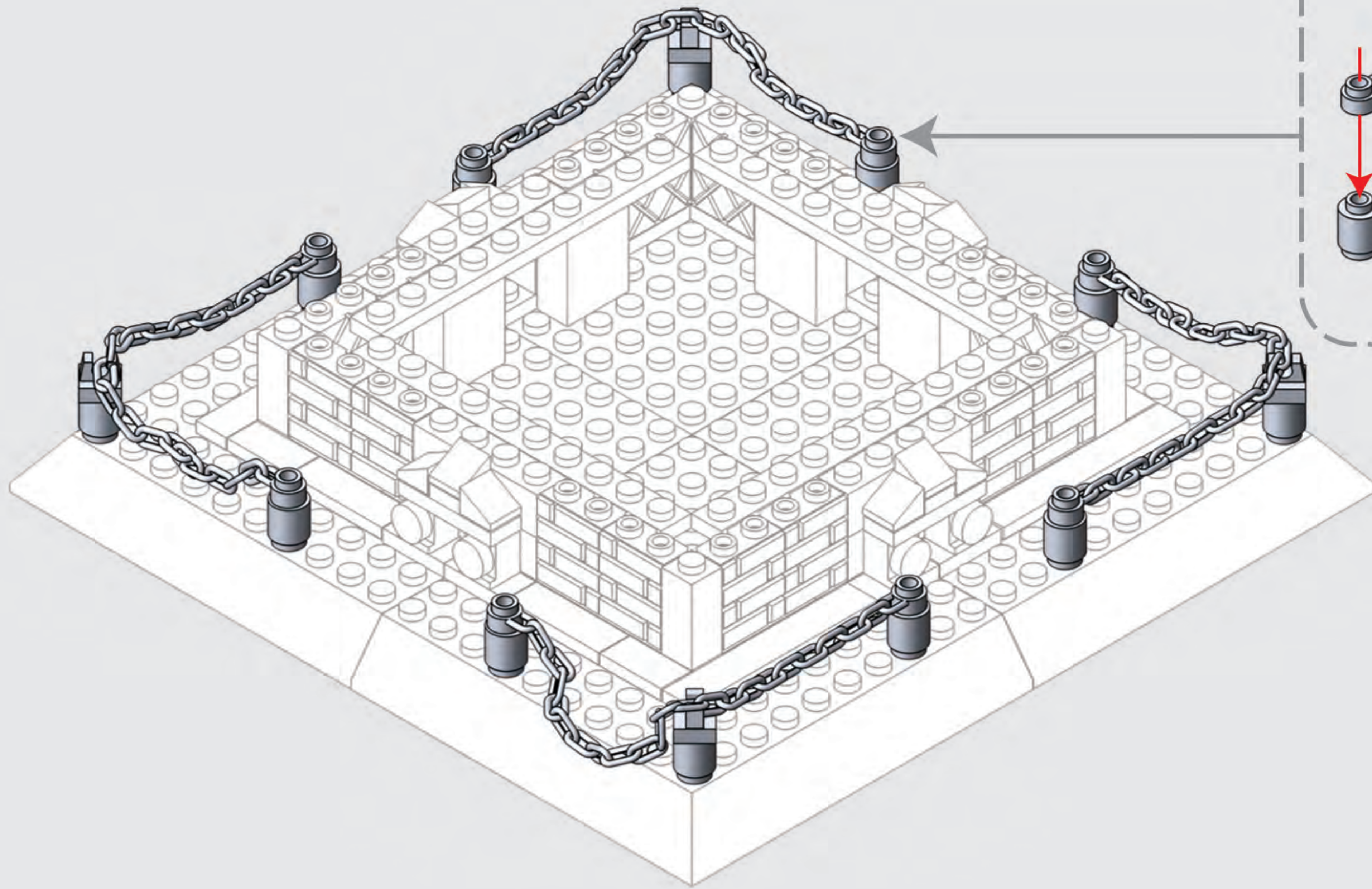
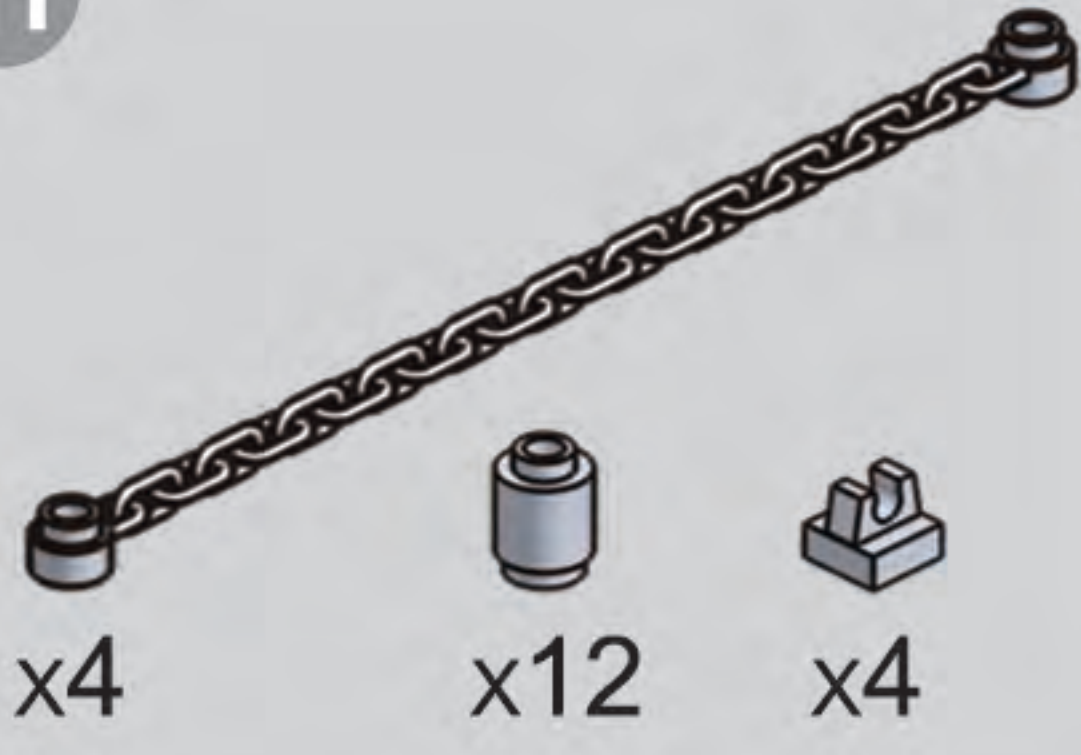

12

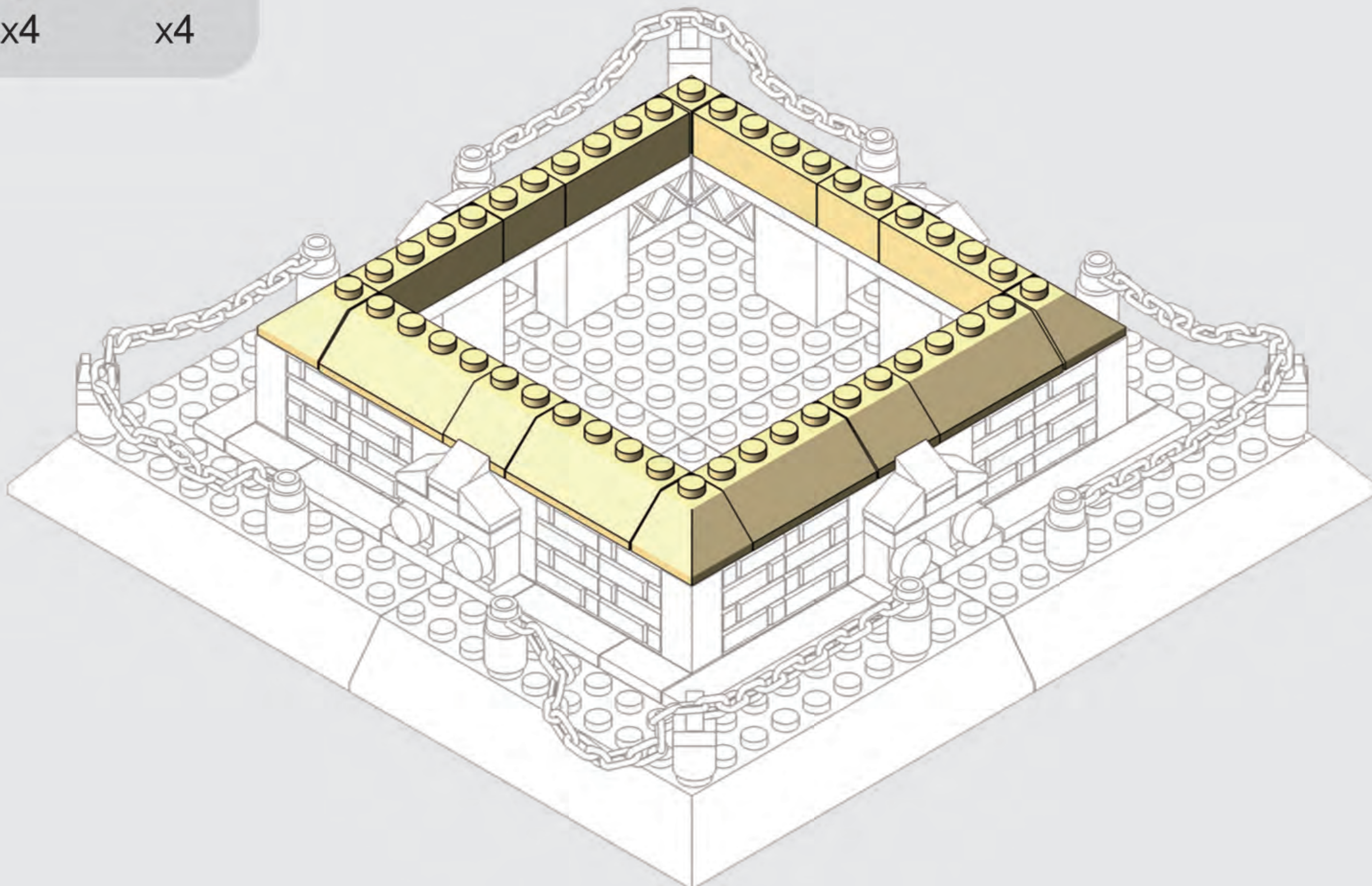

13 2 X 10

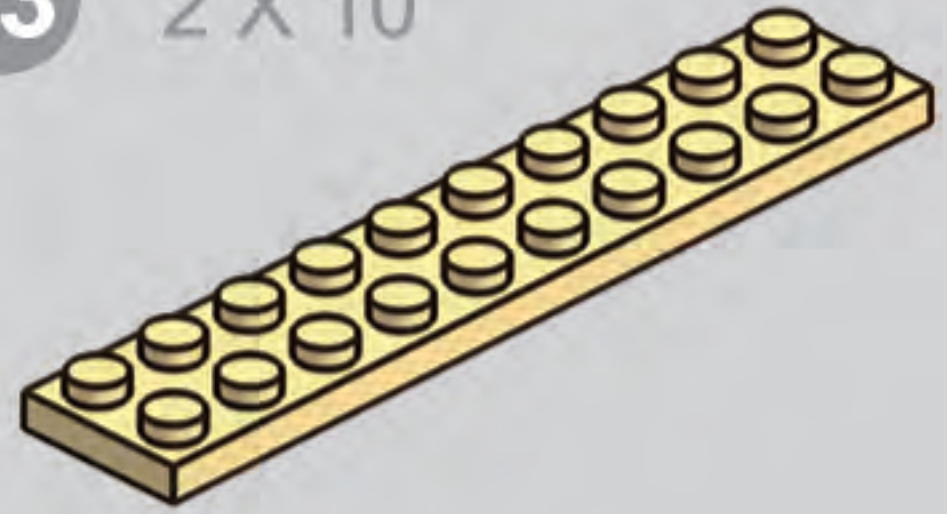

x8

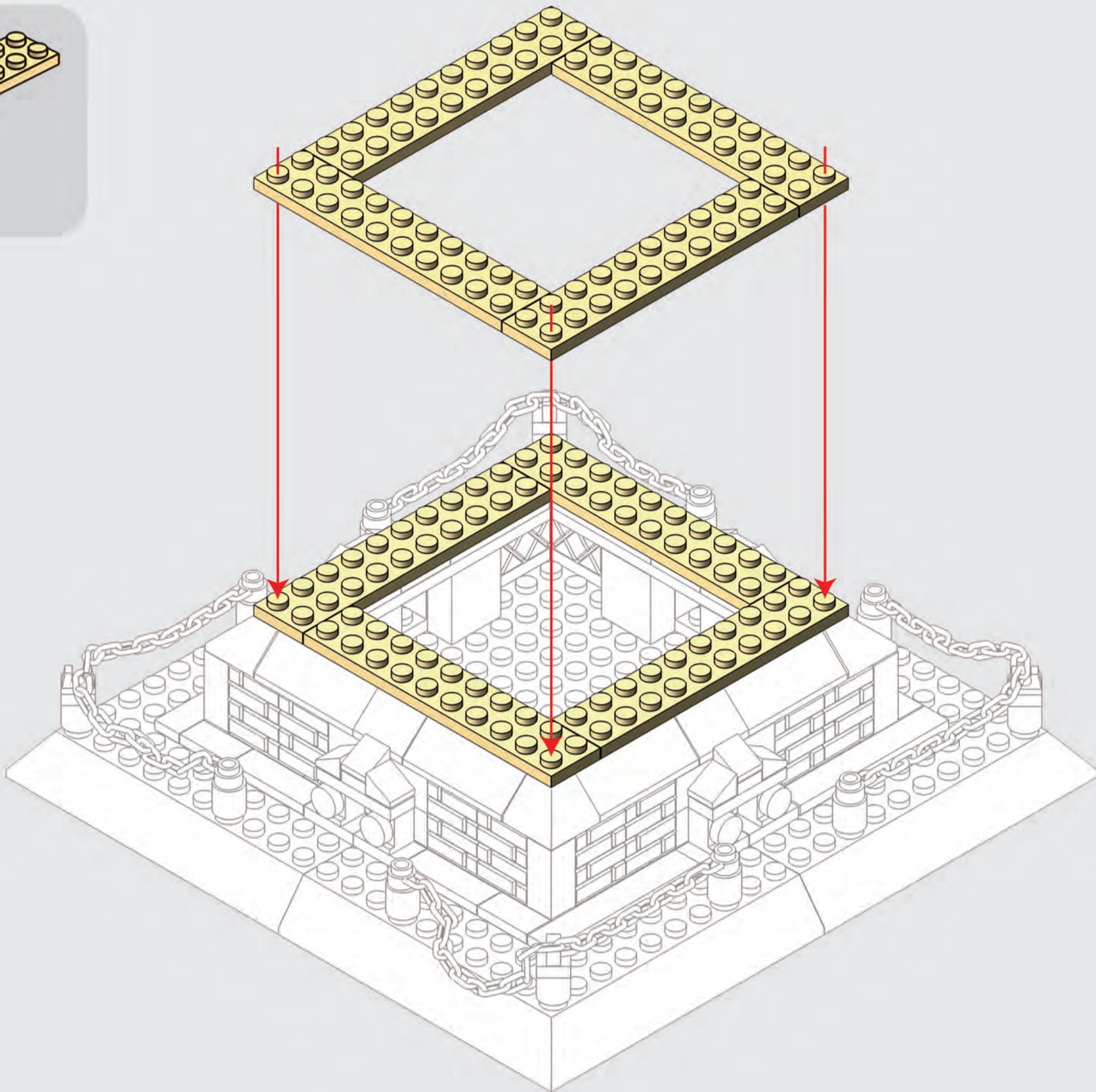

14 1 X 8

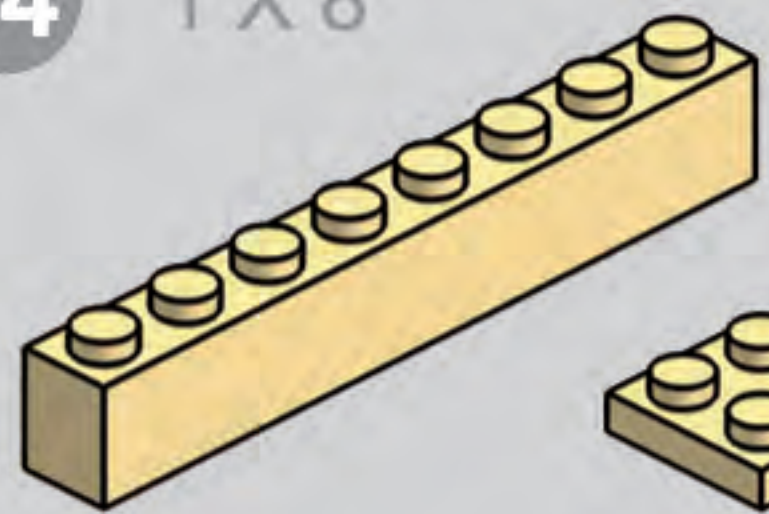

x2



x6



x3



x16

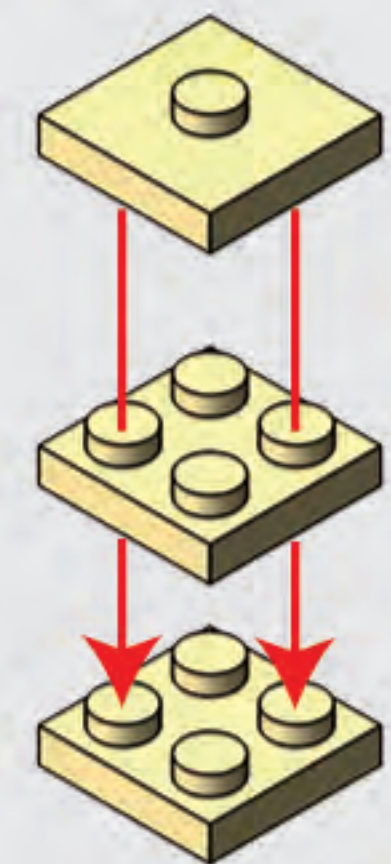
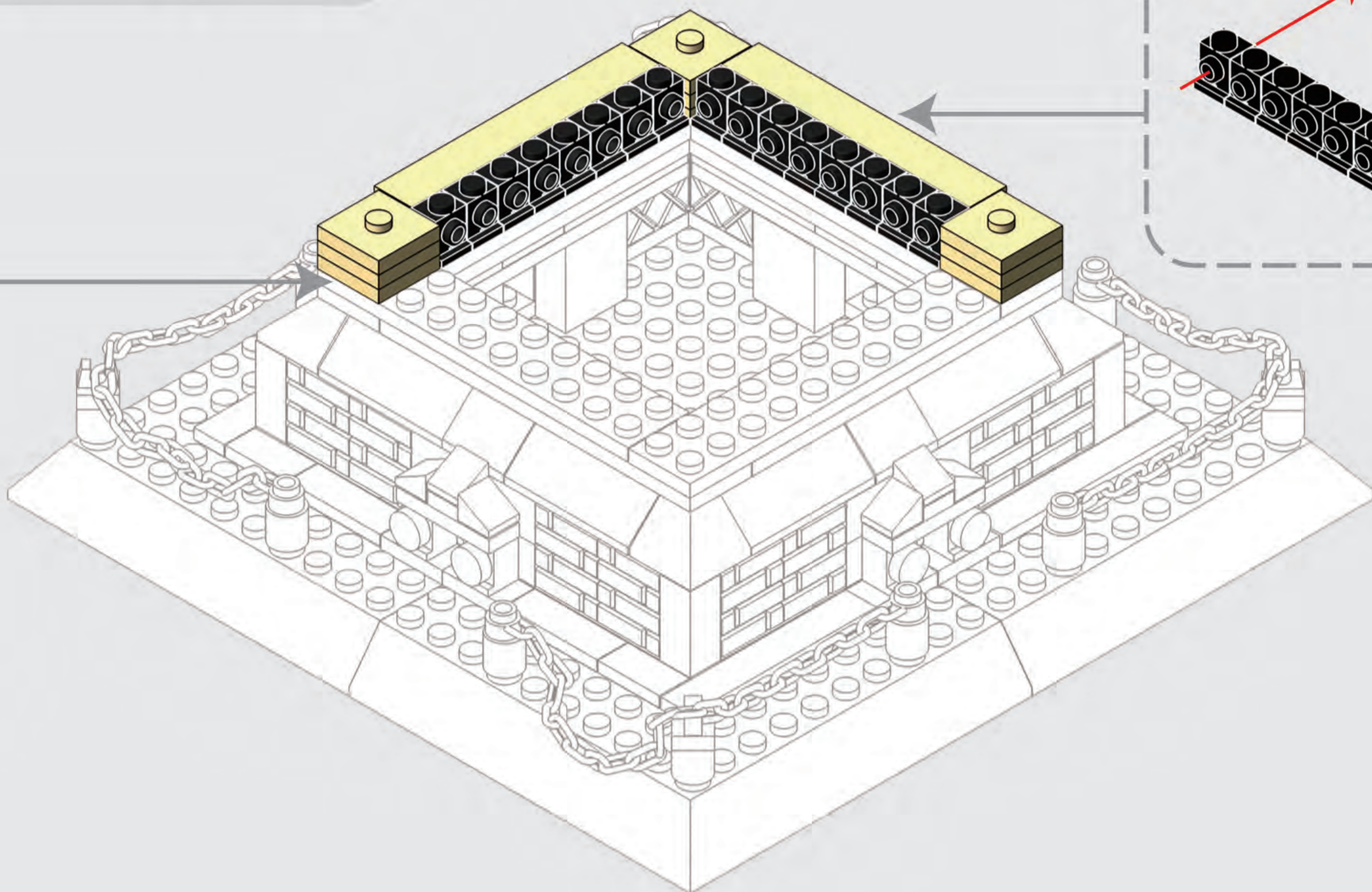

x3

15 1 X 8

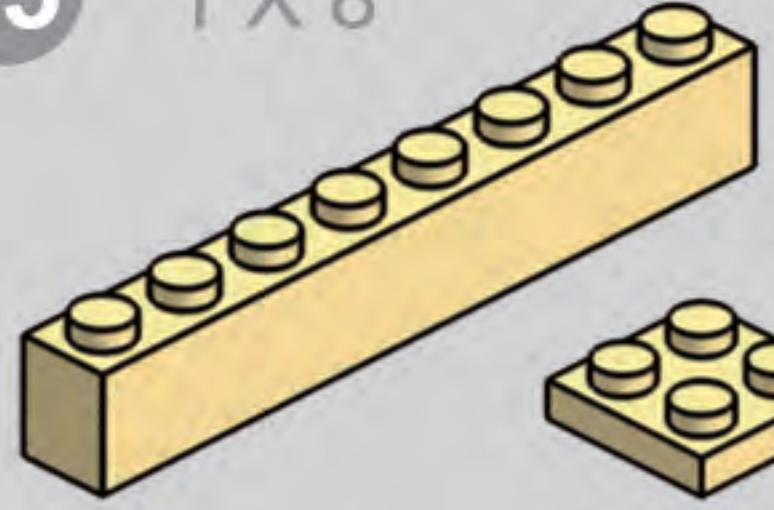

x2



x2



x1



x16

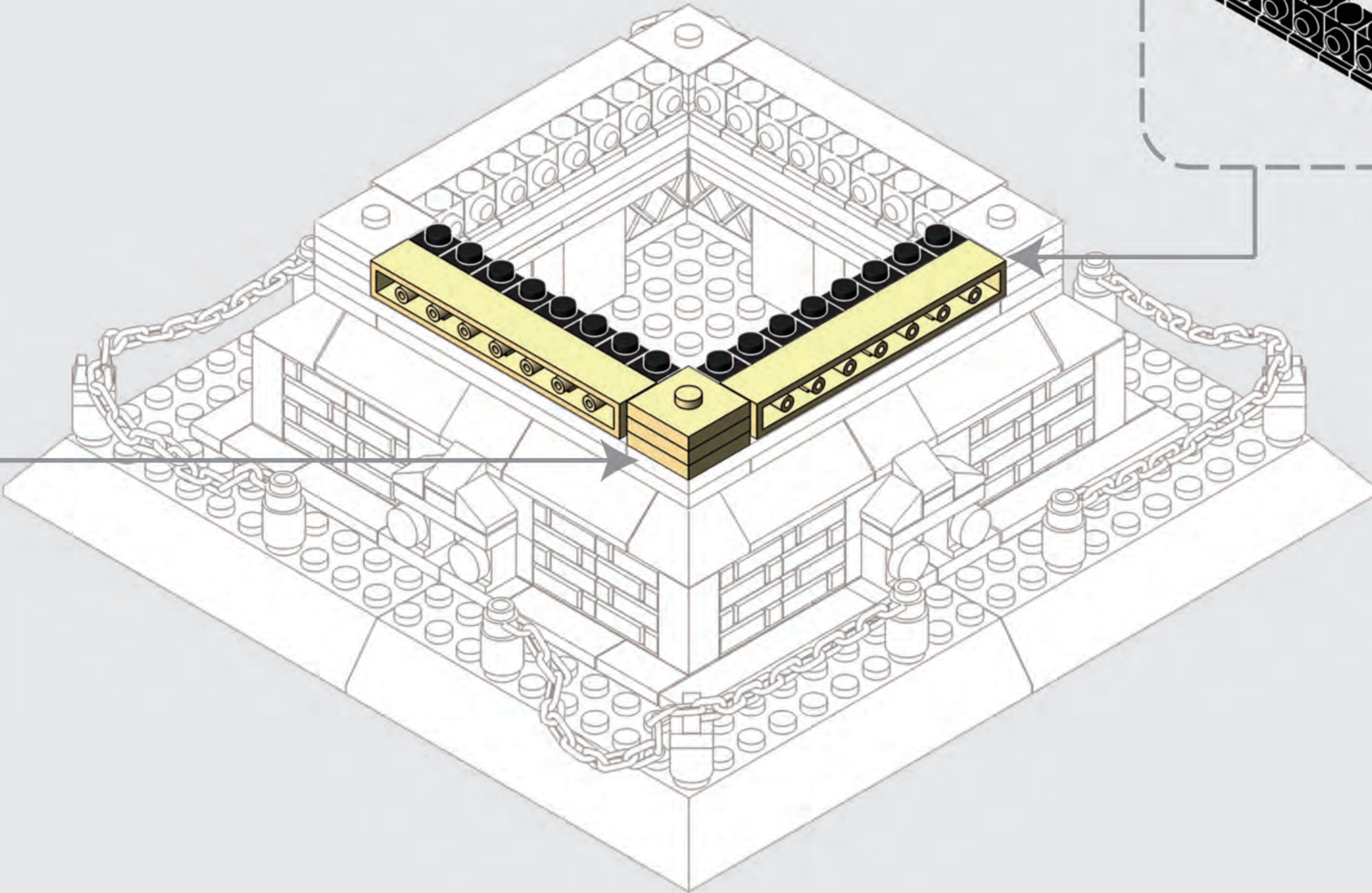
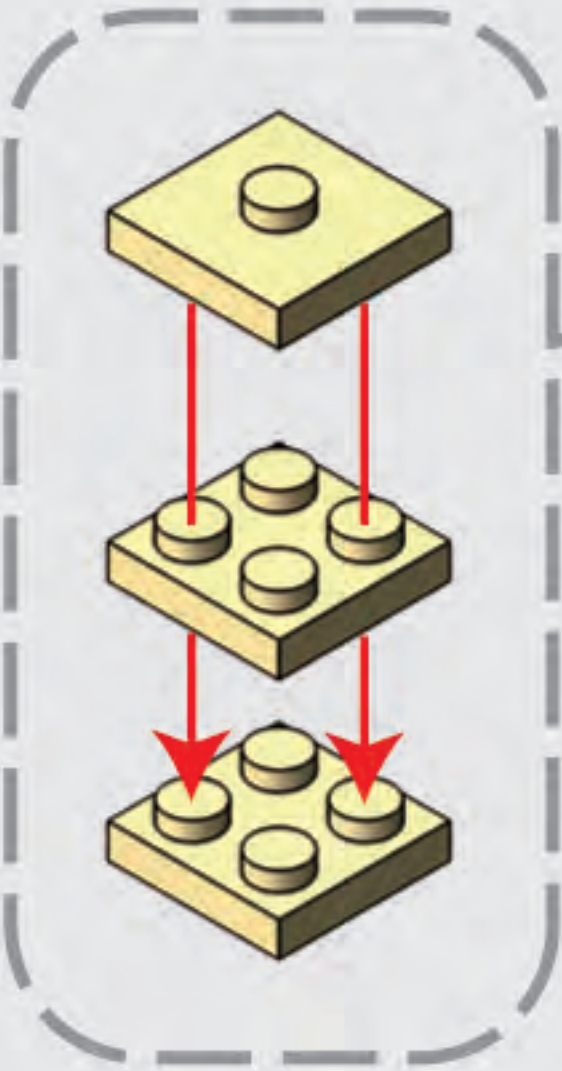
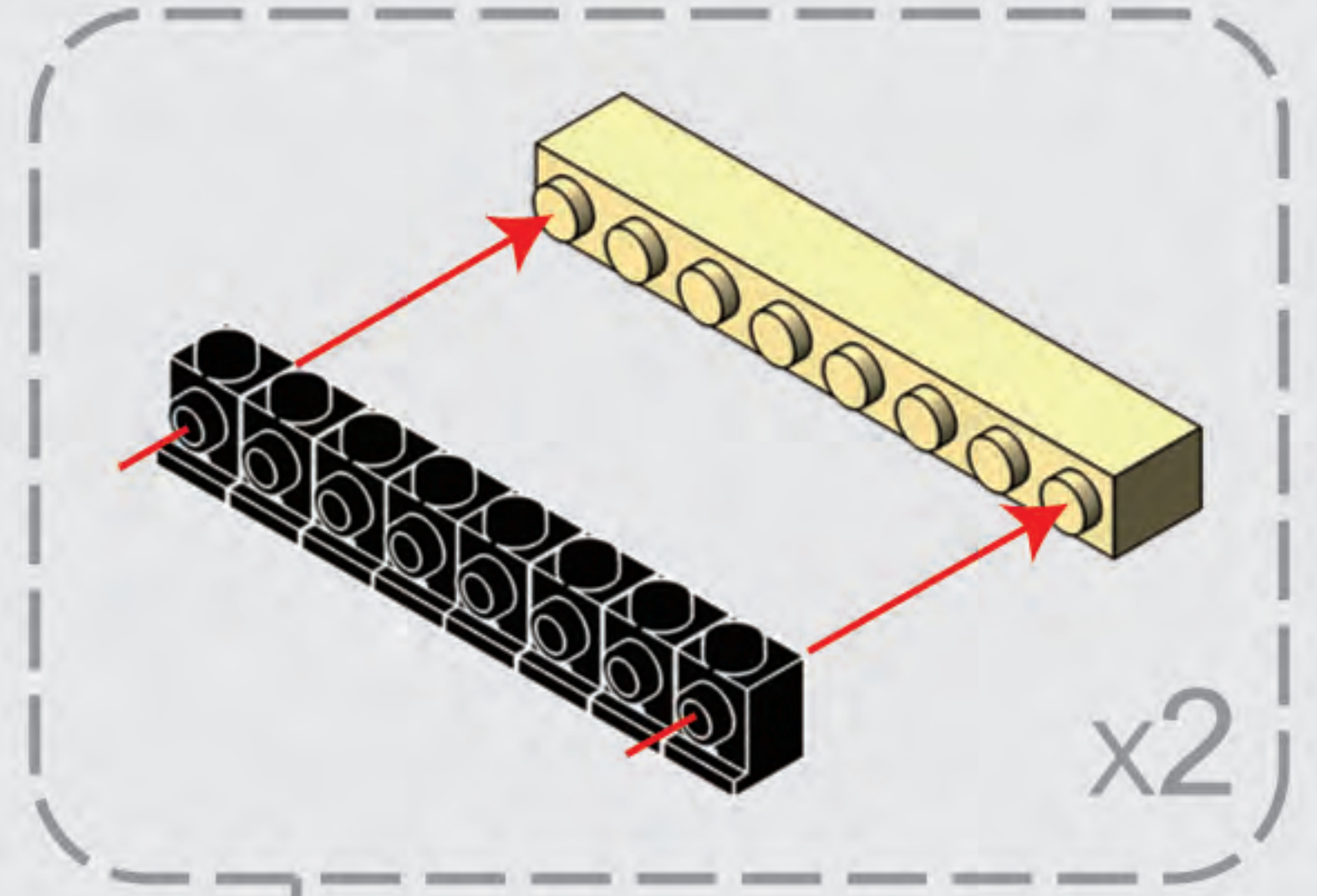

16 2 X 12

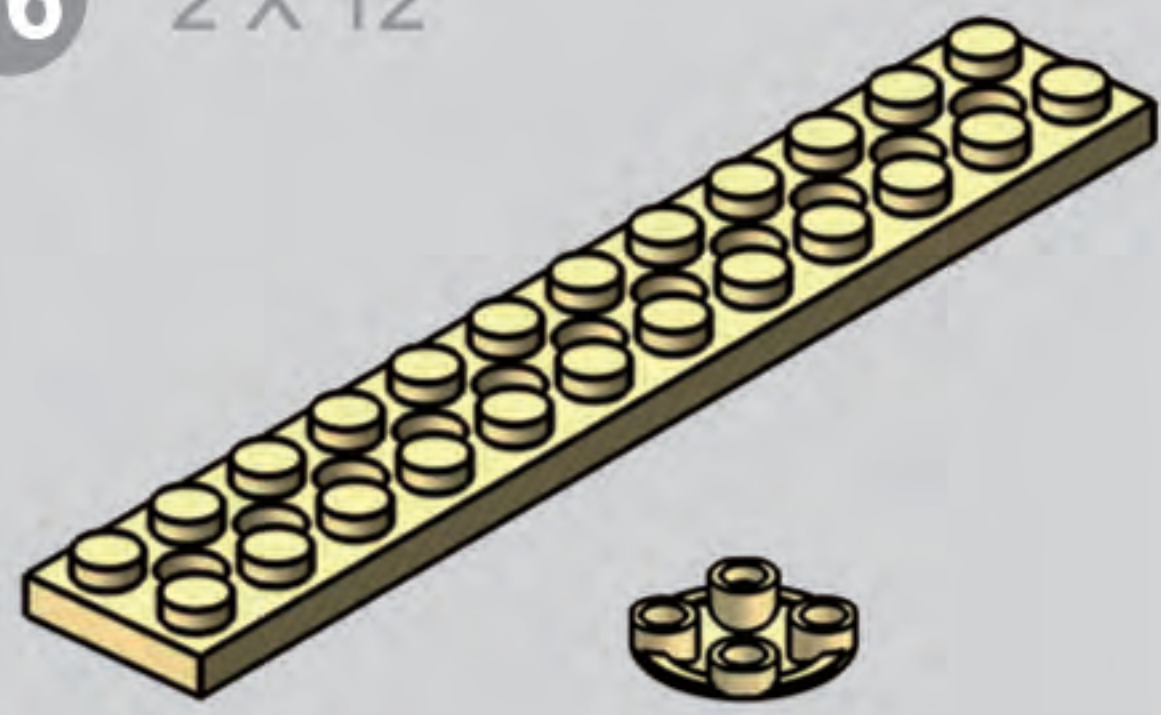

x4



x24

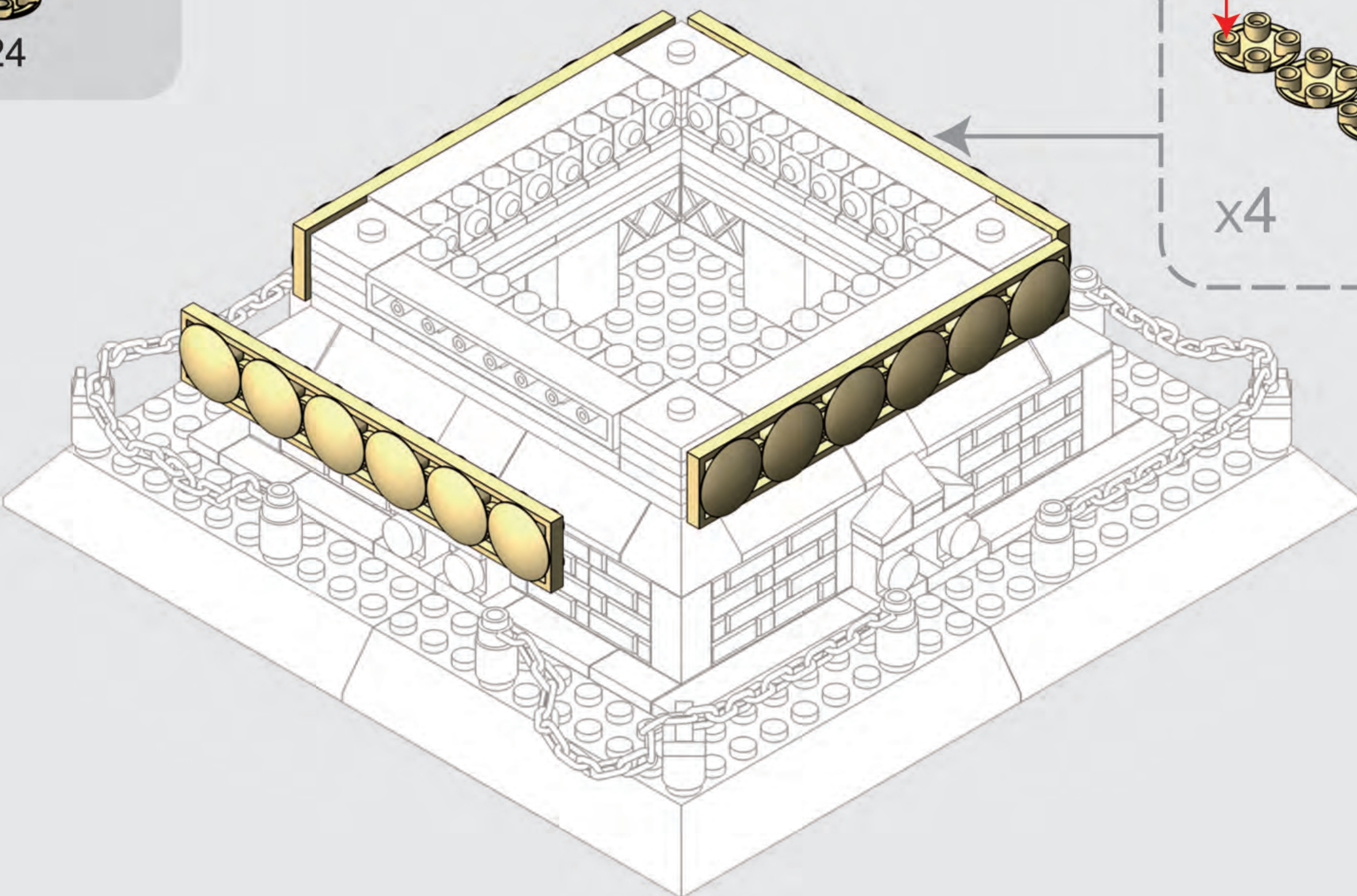
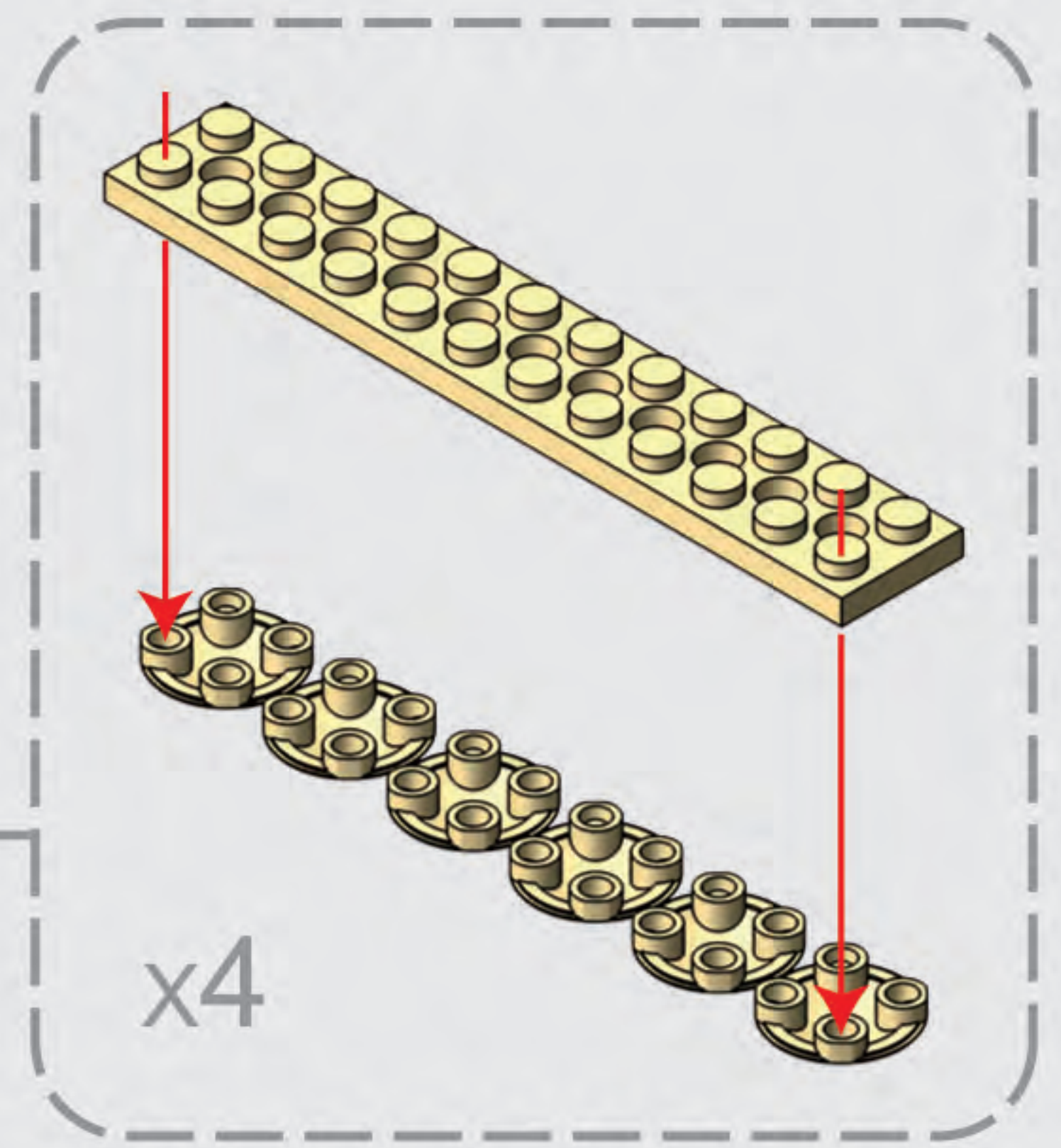

17



x14

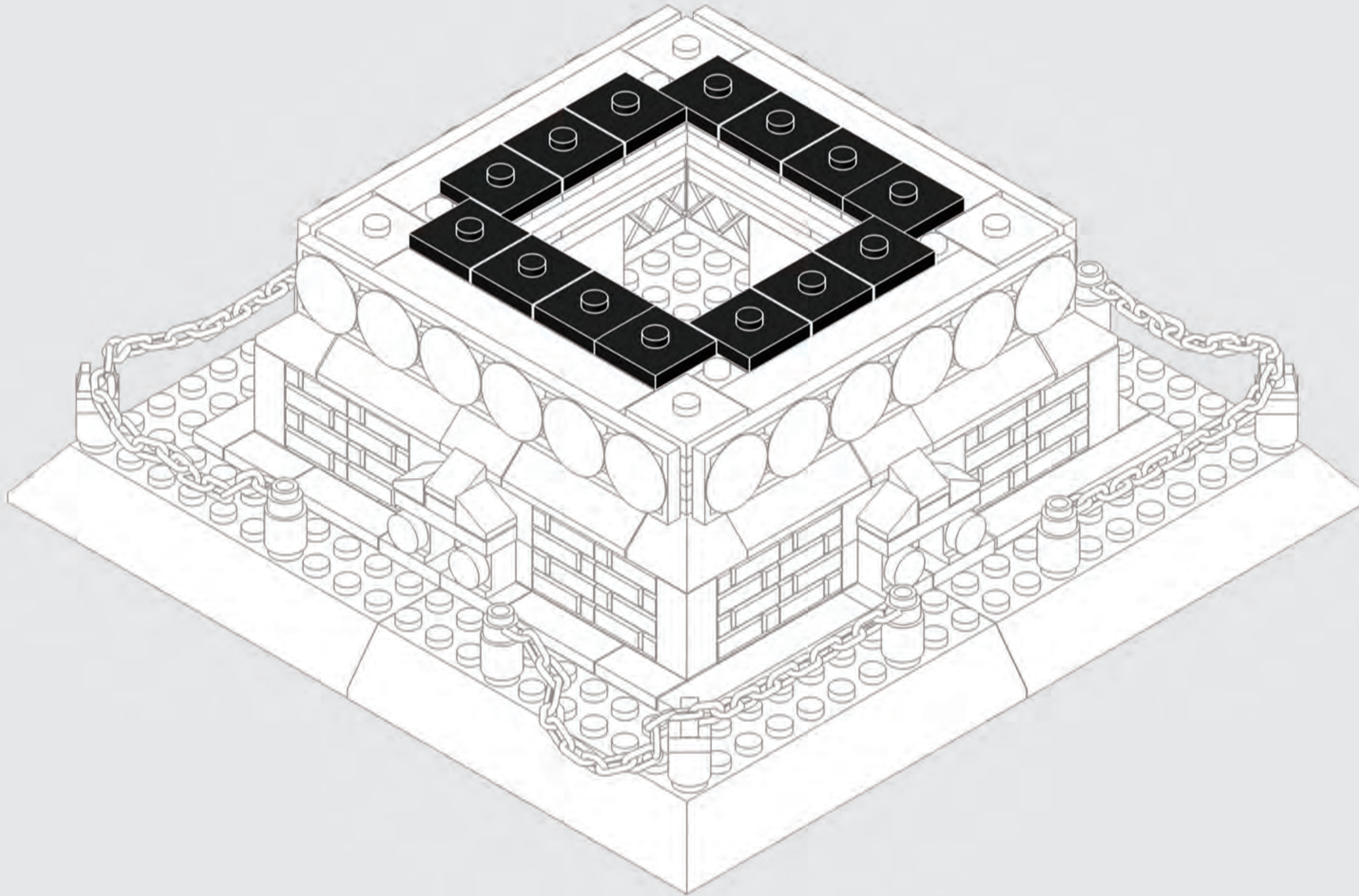

18

4 X 6

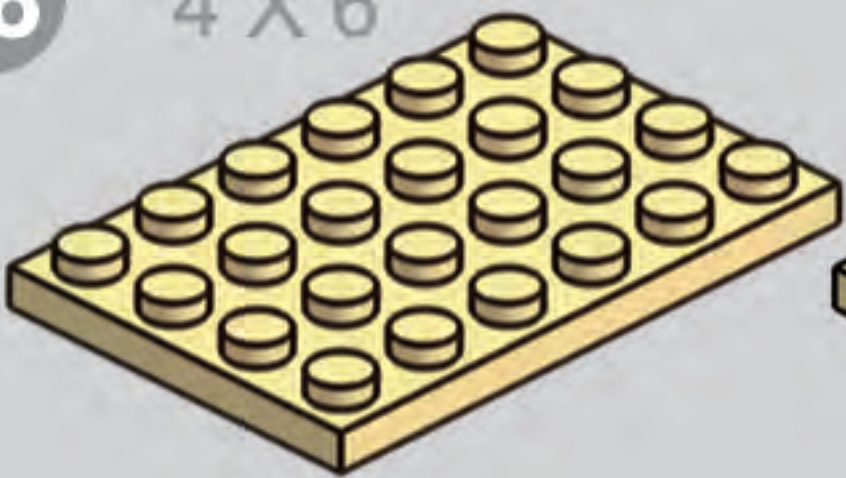

x4

4 X 4



x2

1 X 6



x4



x4



x4

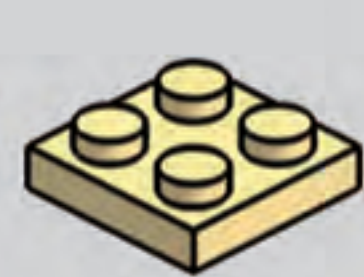

x4

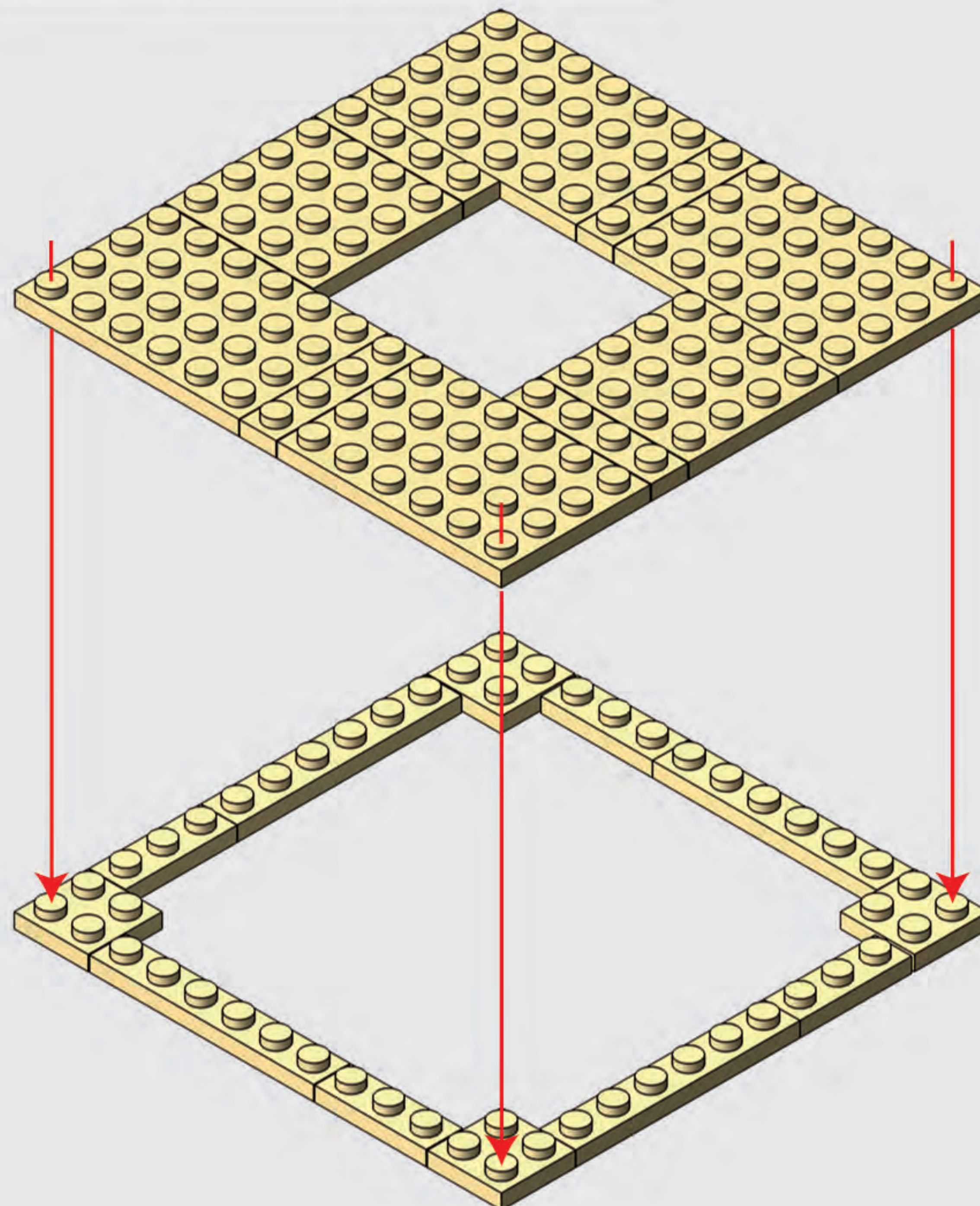

19

17 + 18

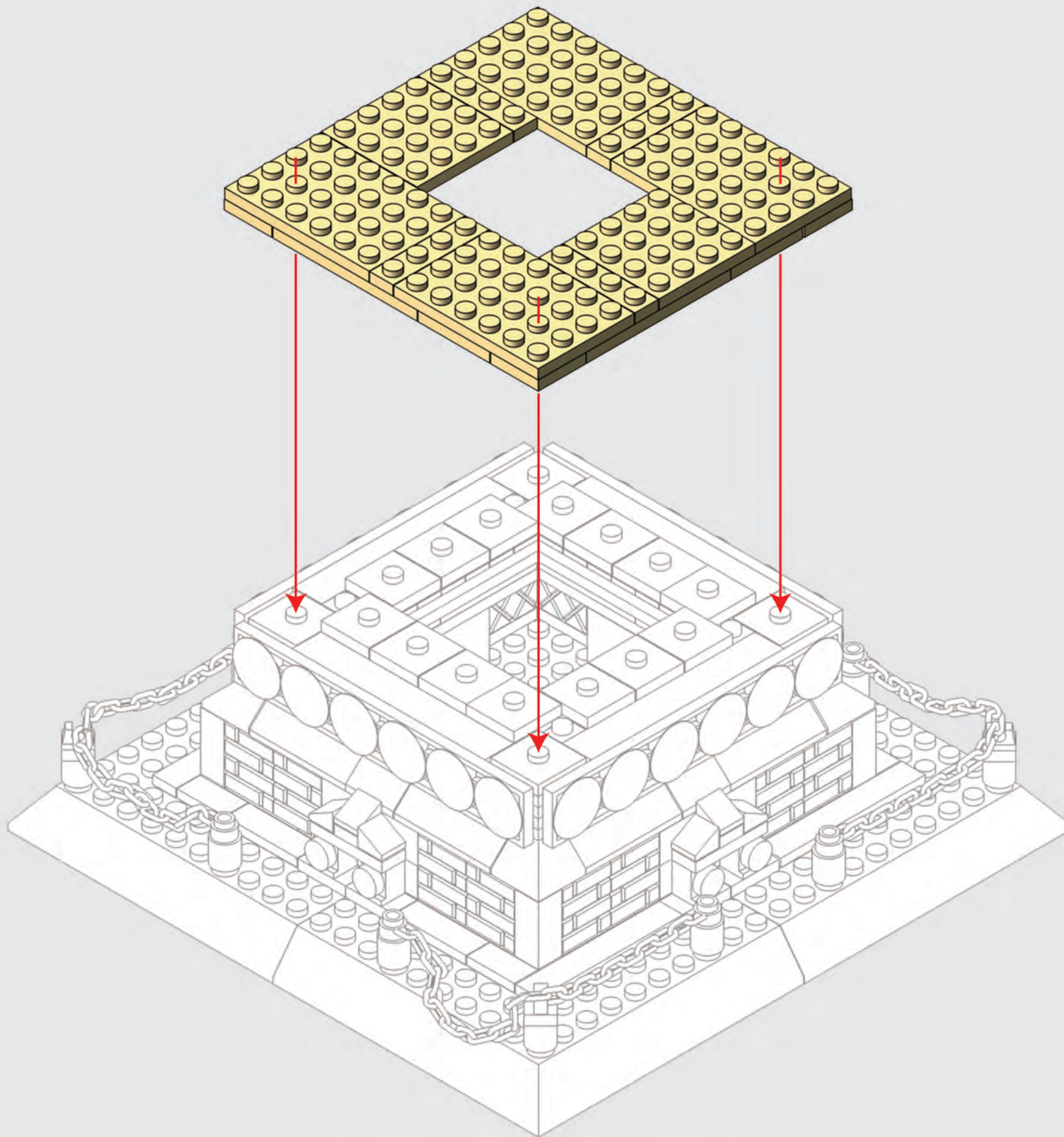

20

x20 x16

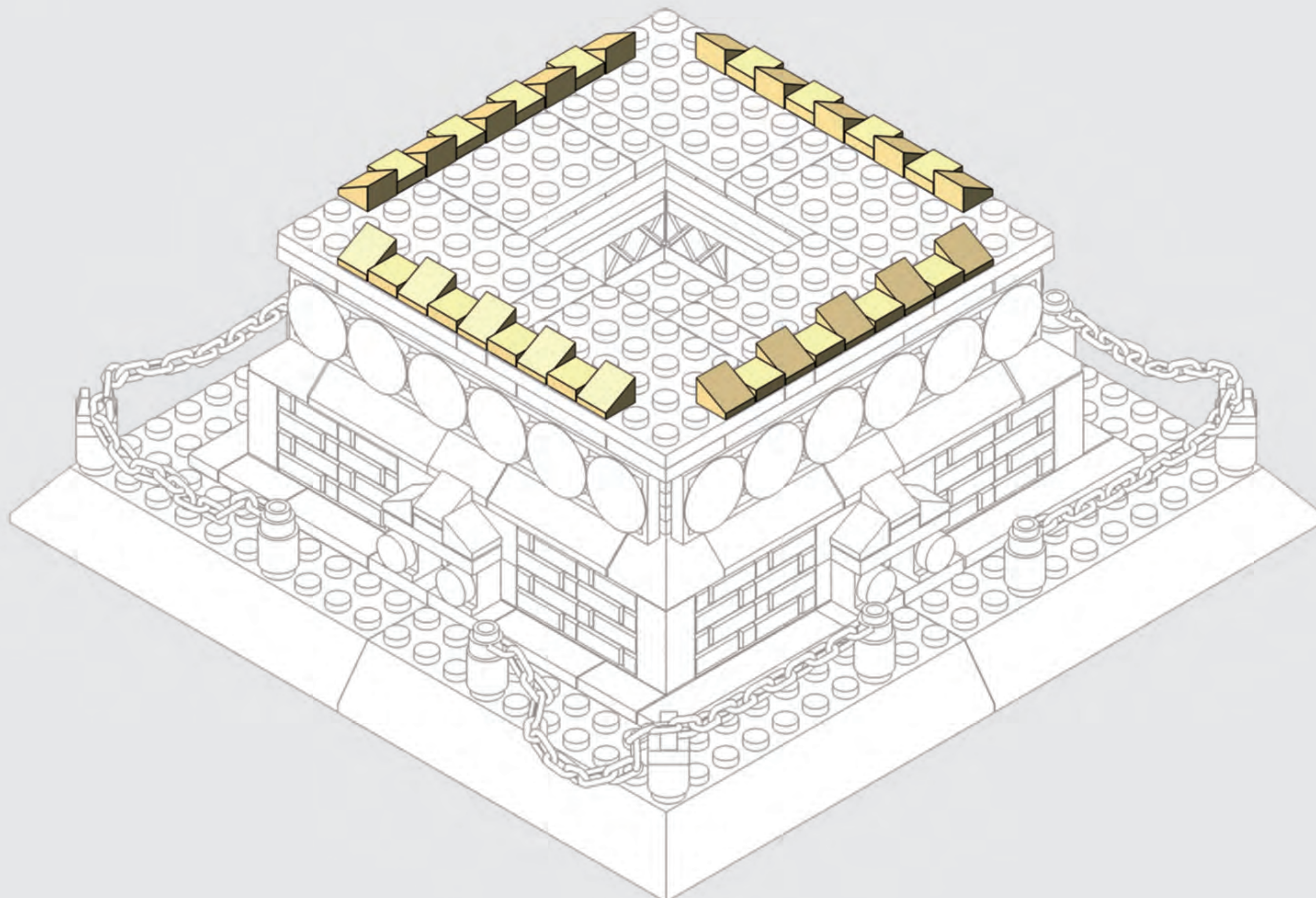

21

1 X 6

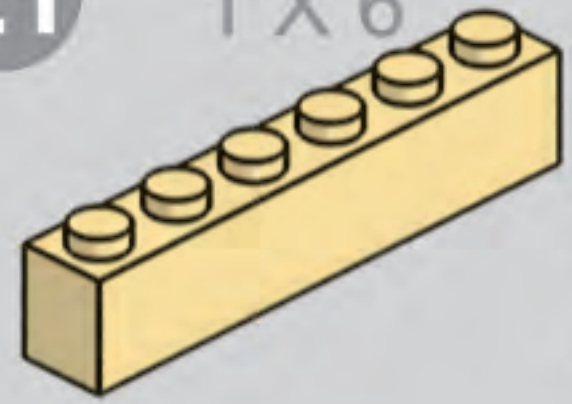

x2

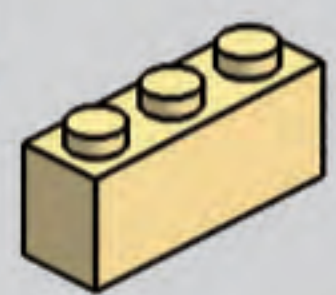

x2



x3

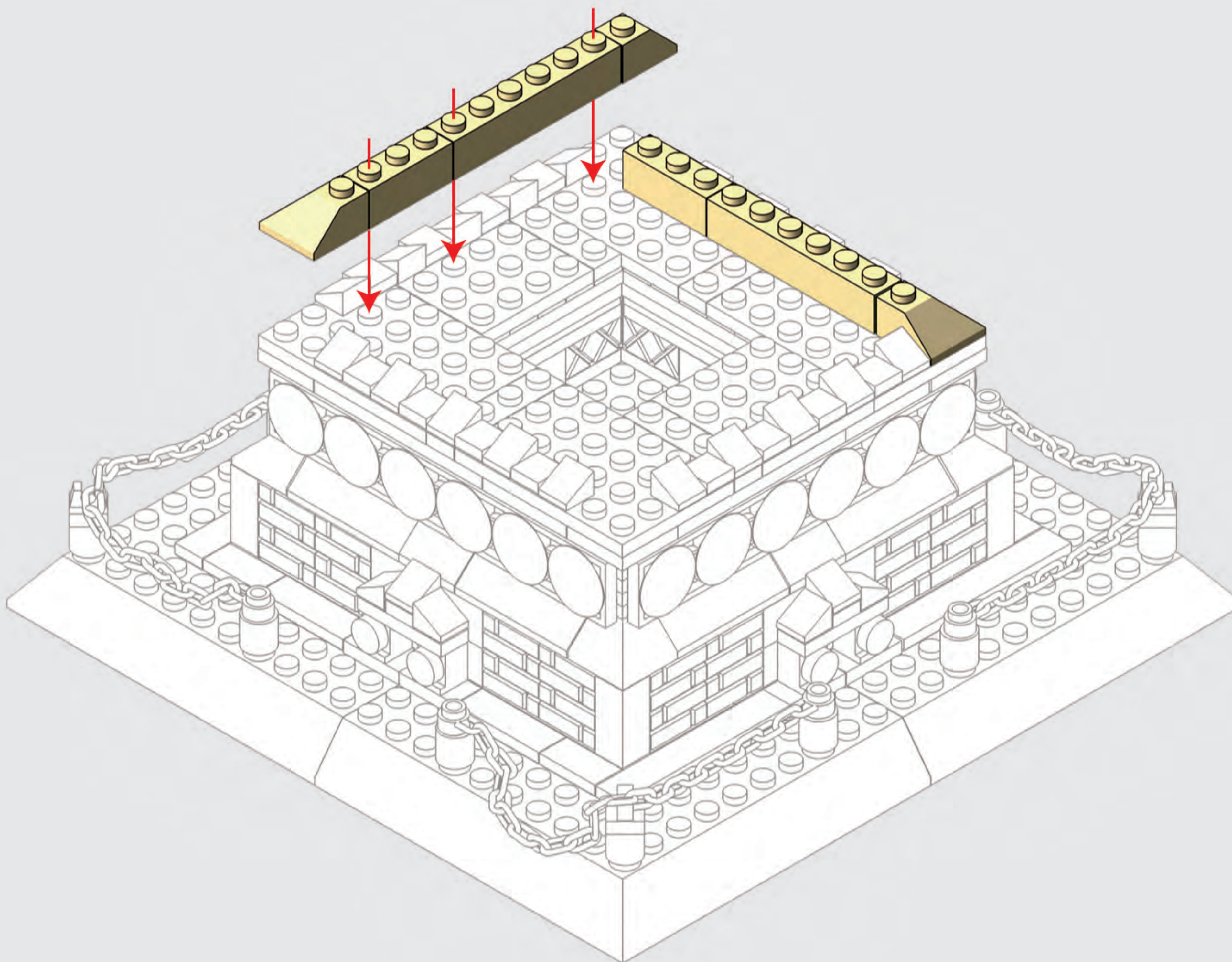

22



x4



x8

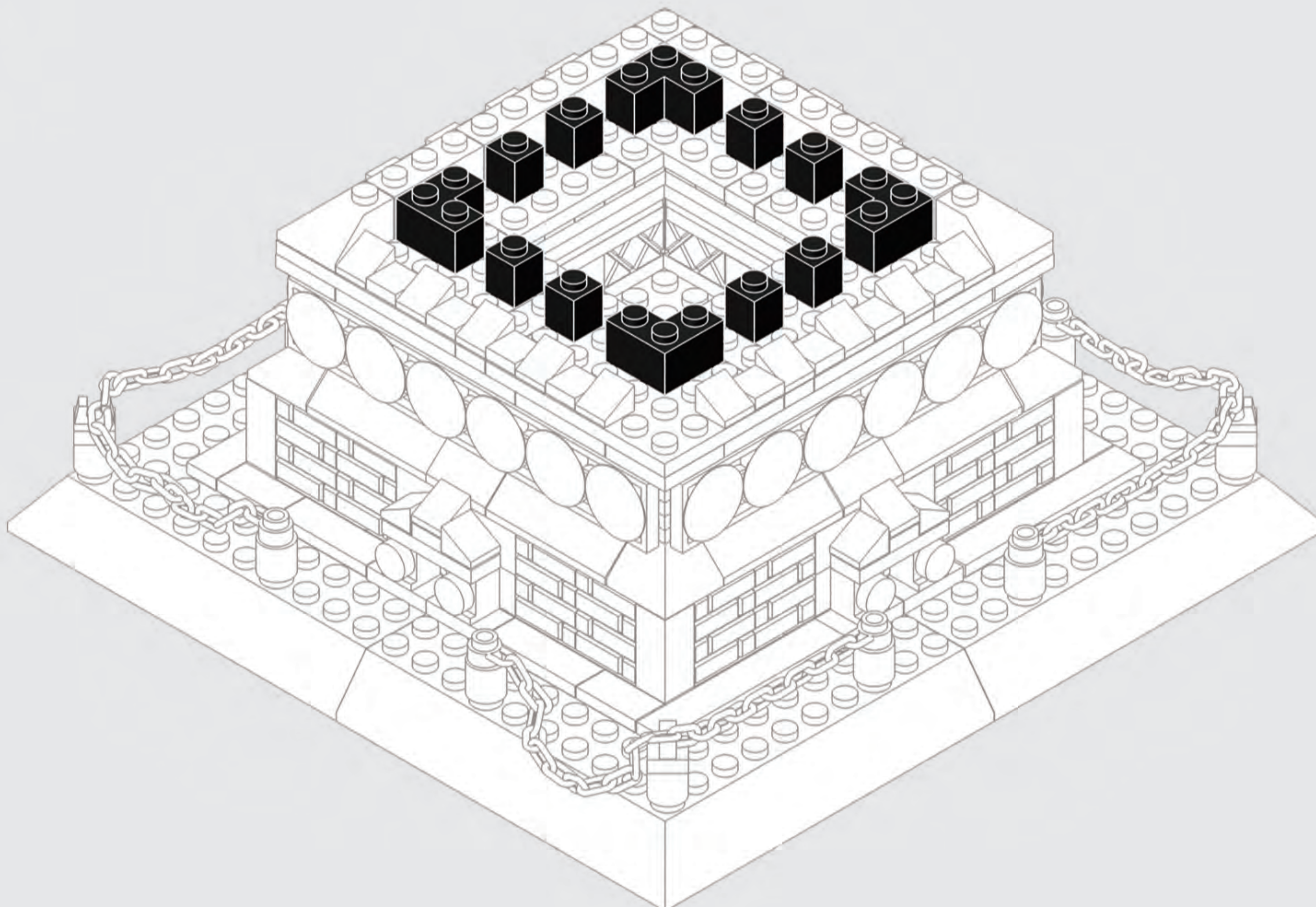

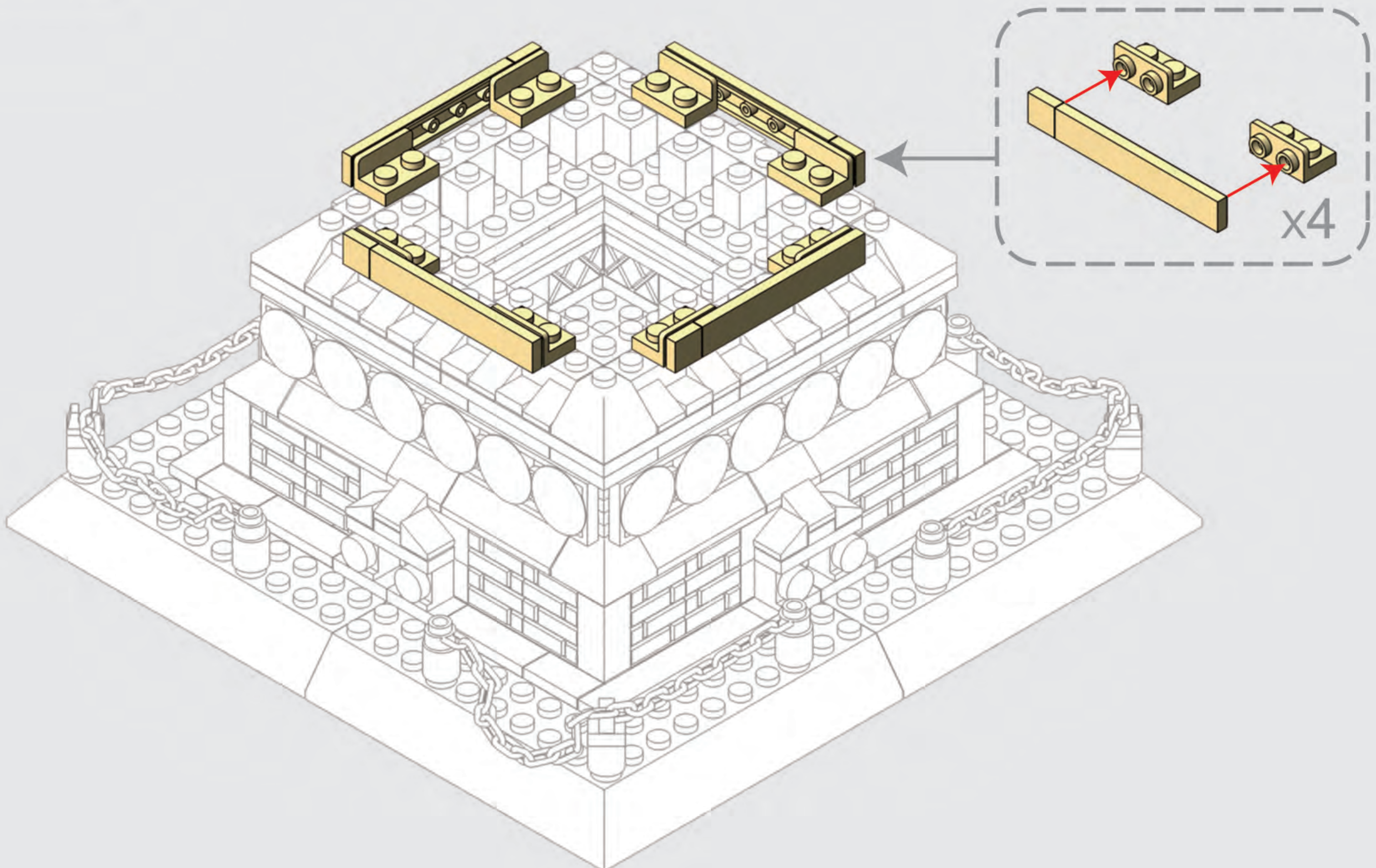
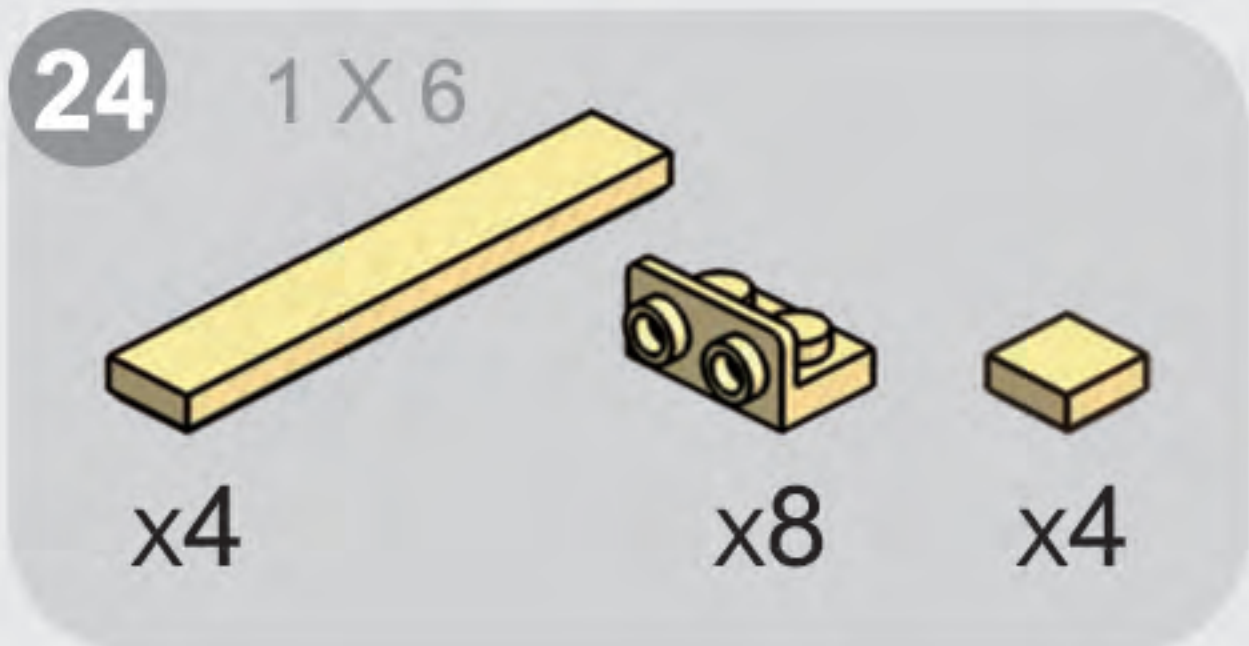
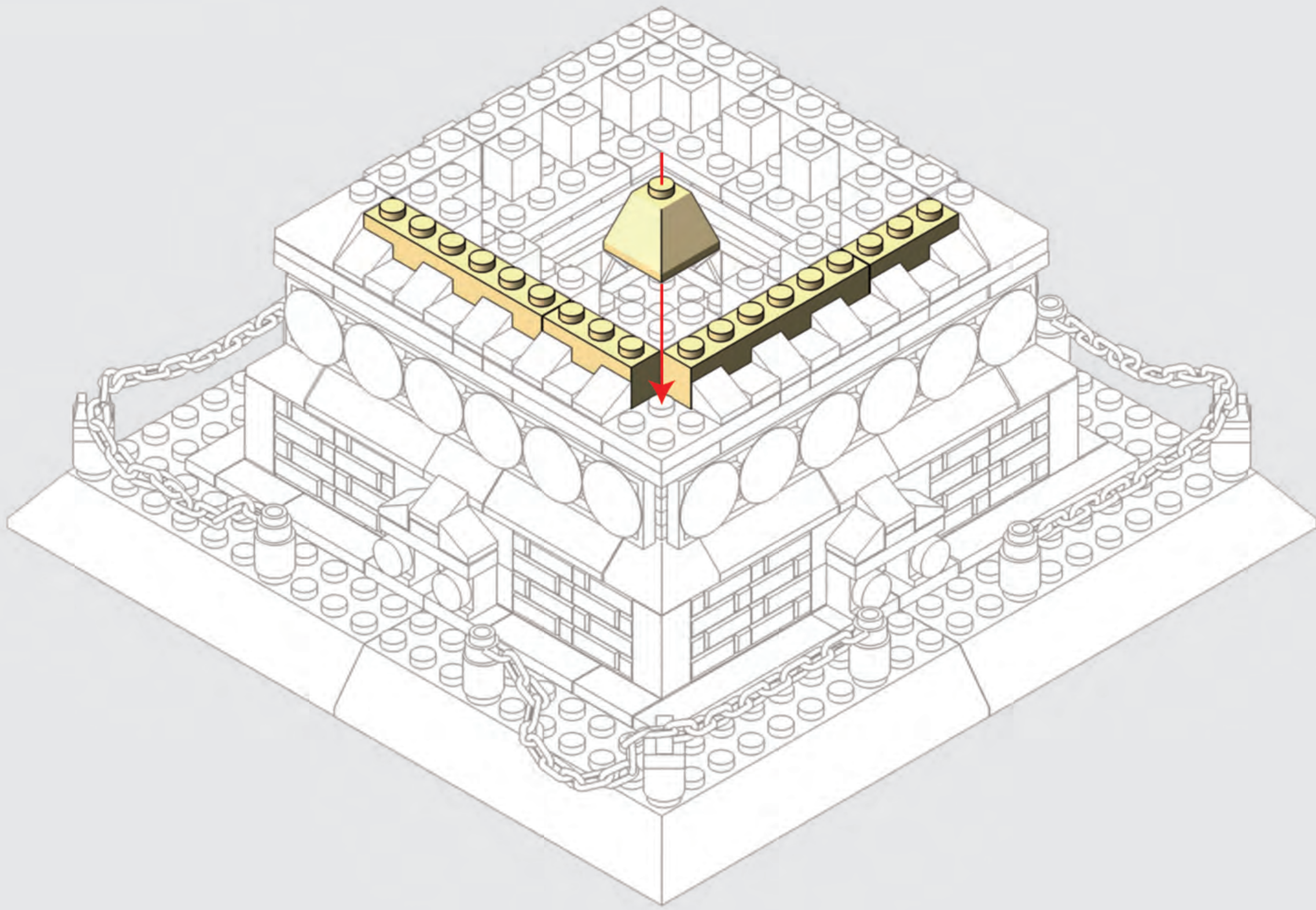
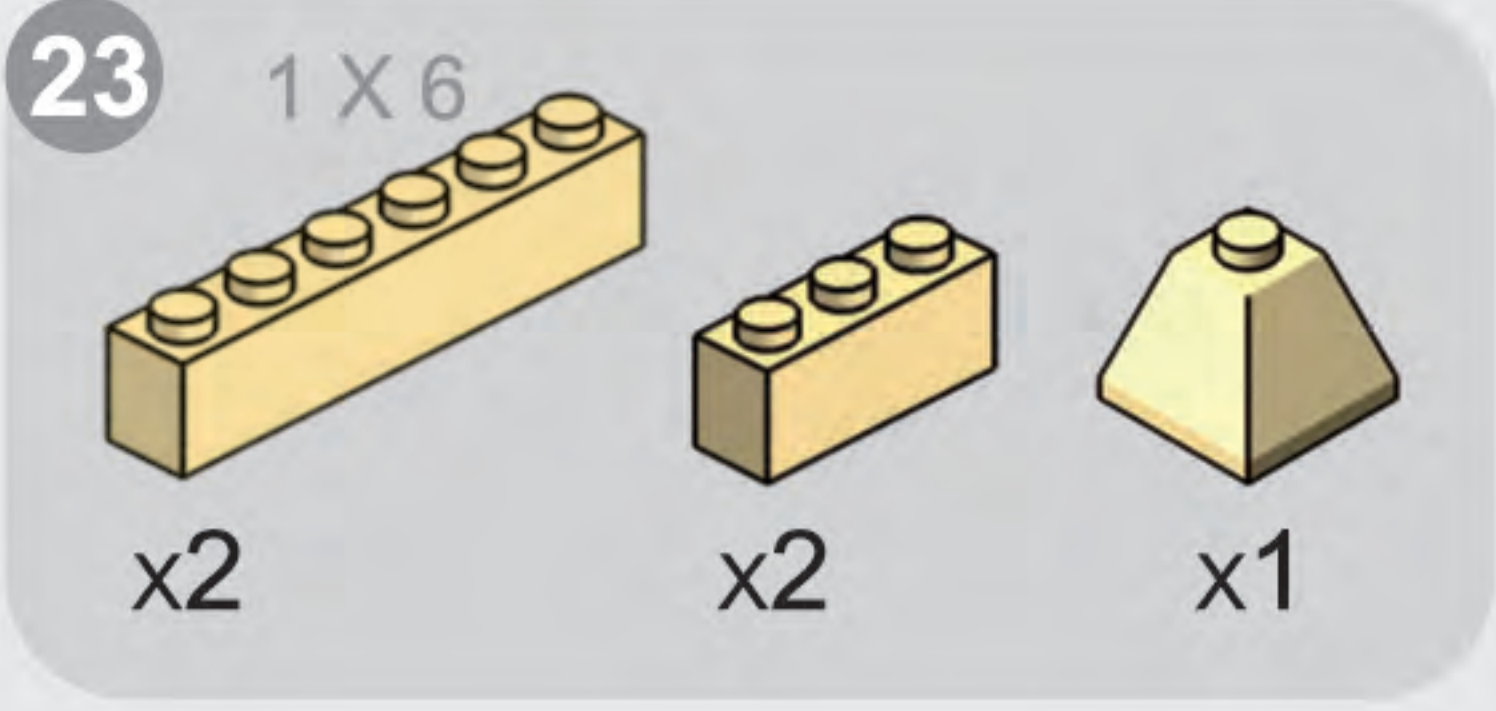

25

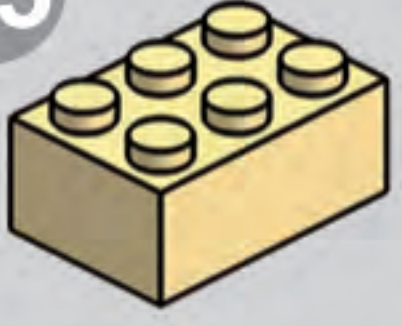

x4



x8

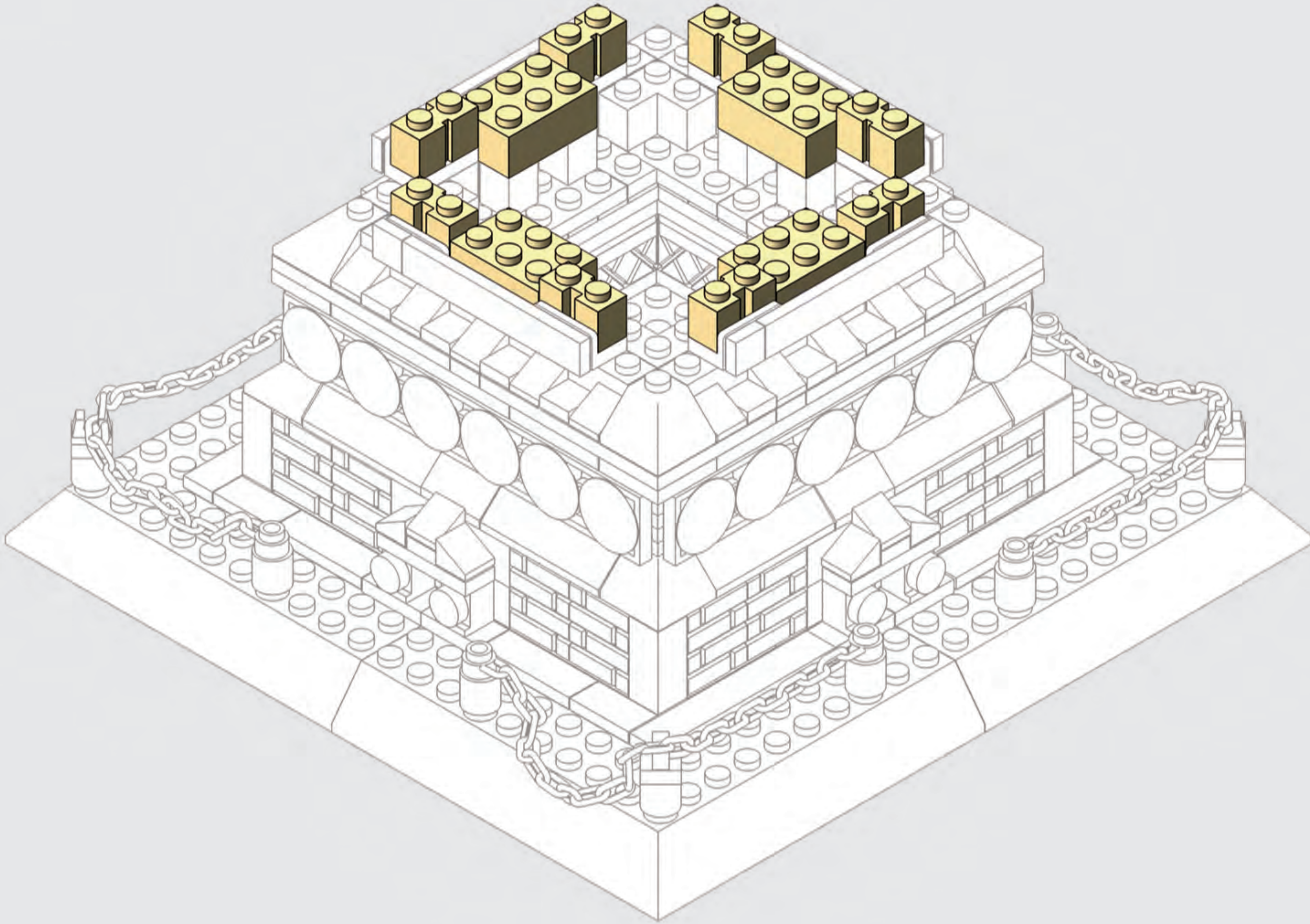

26



x12



x8

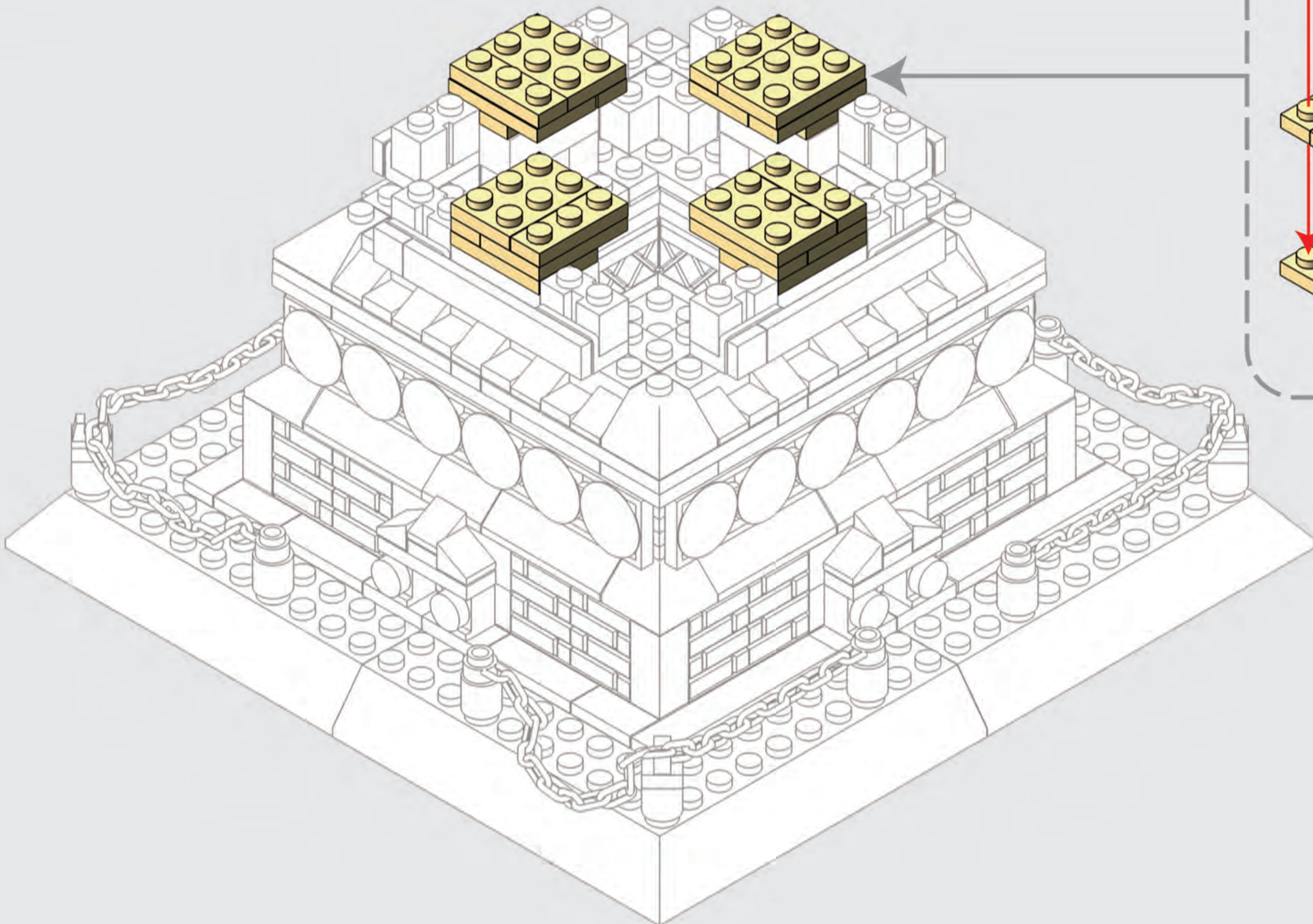

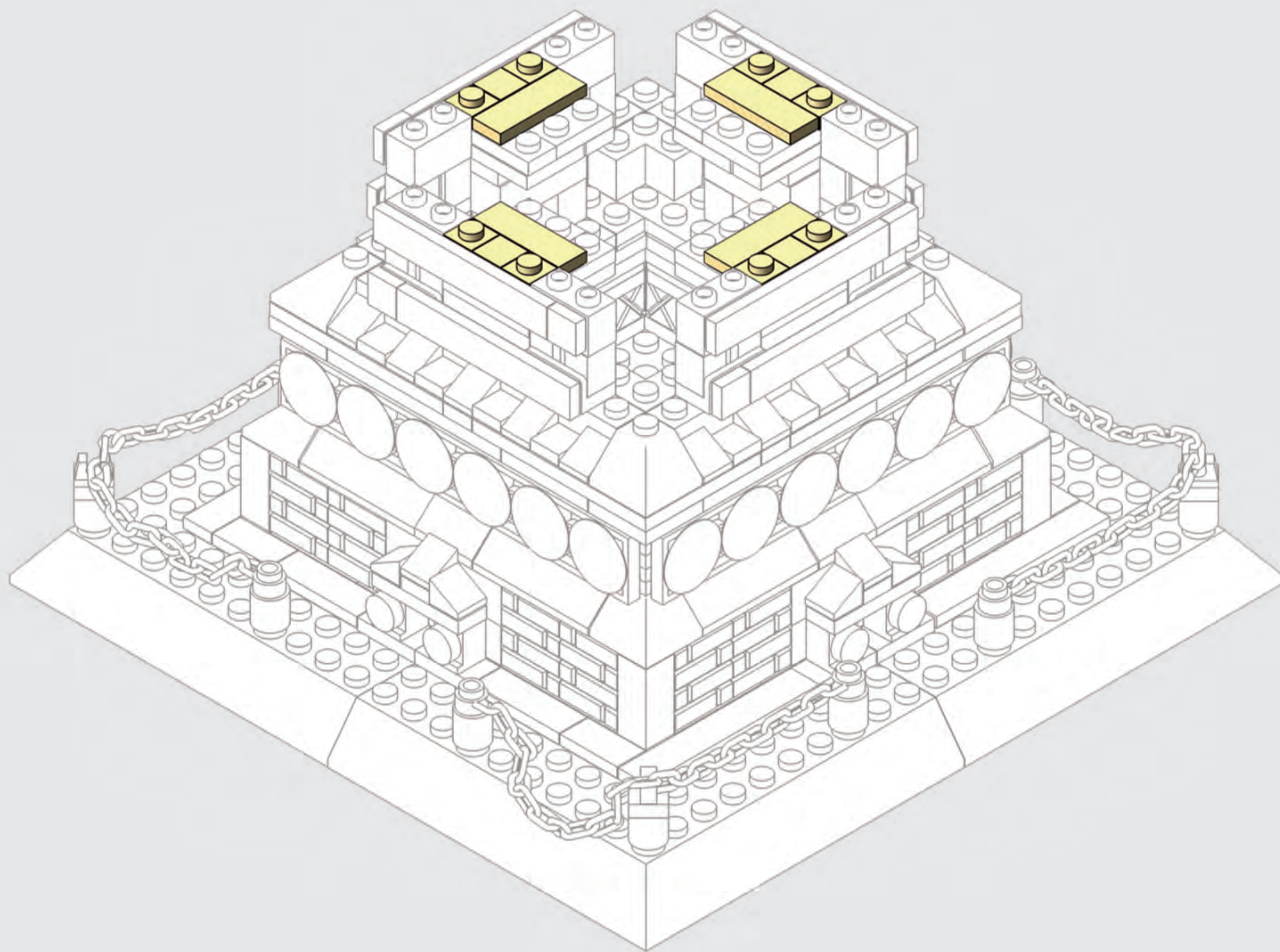
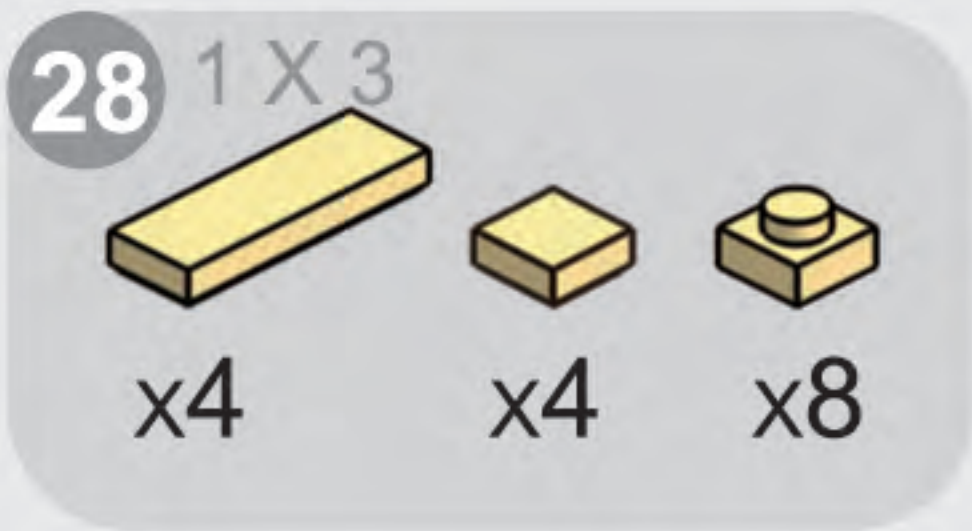
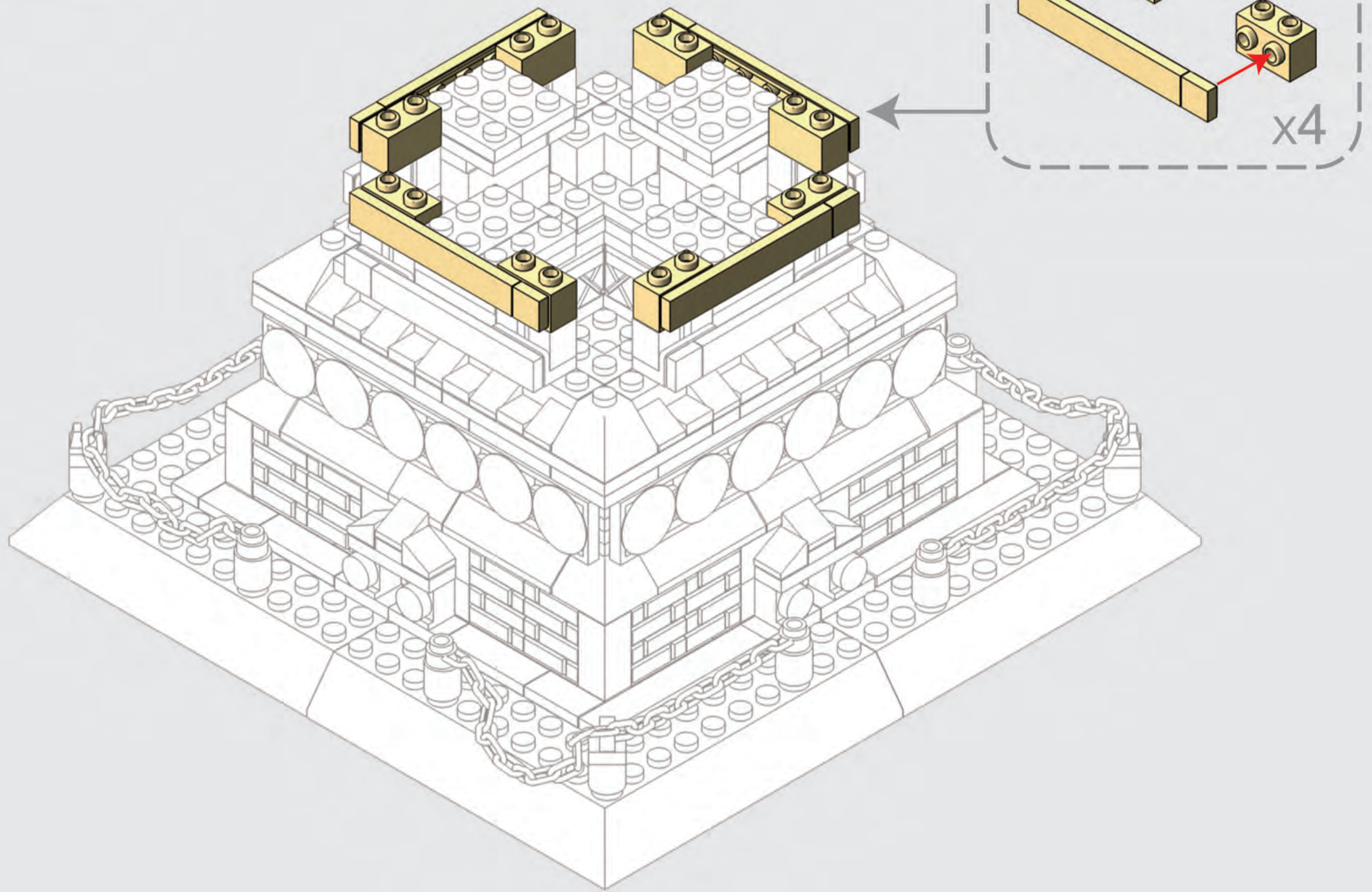
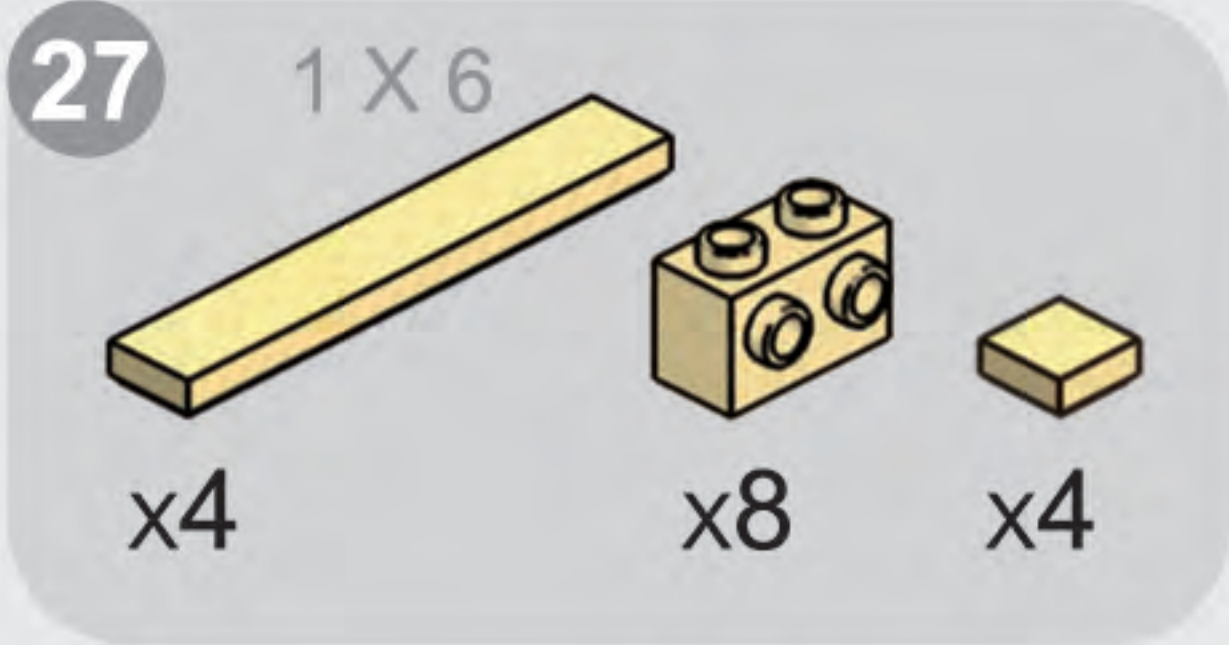

29

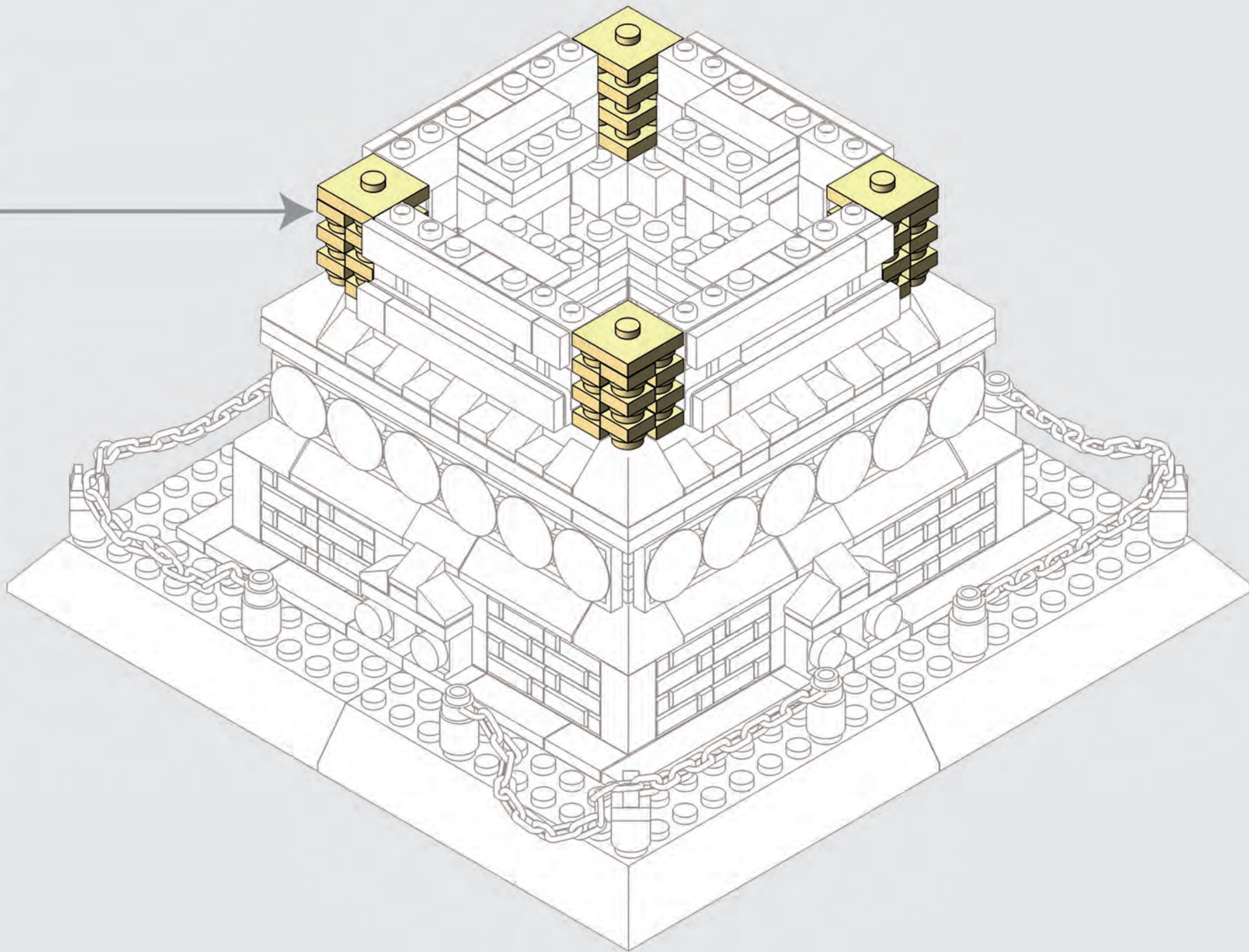
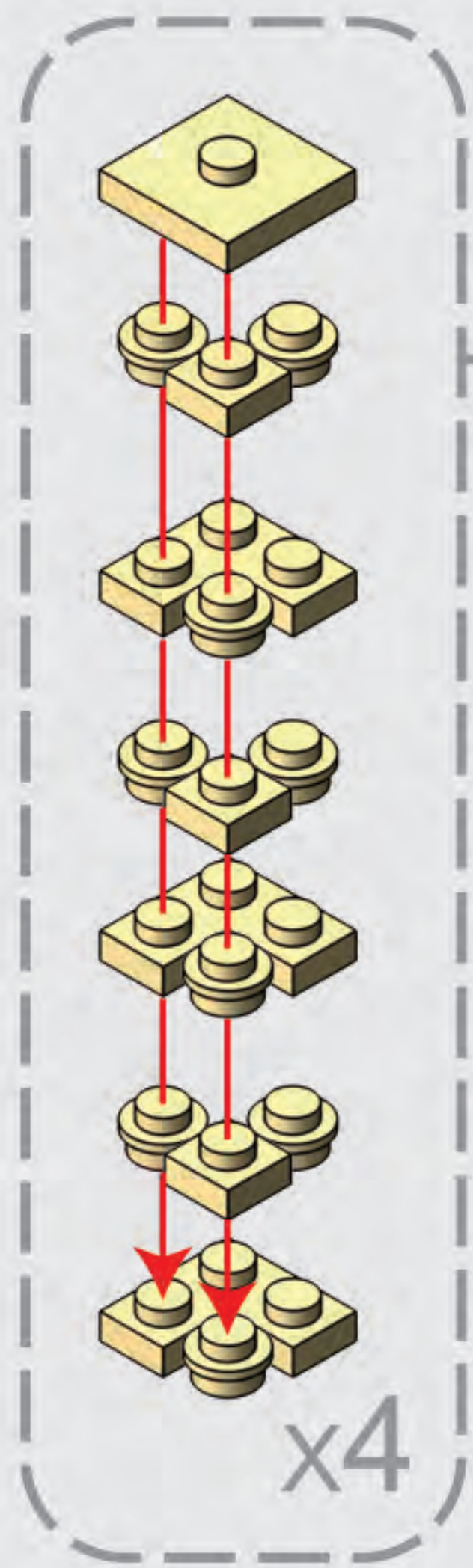
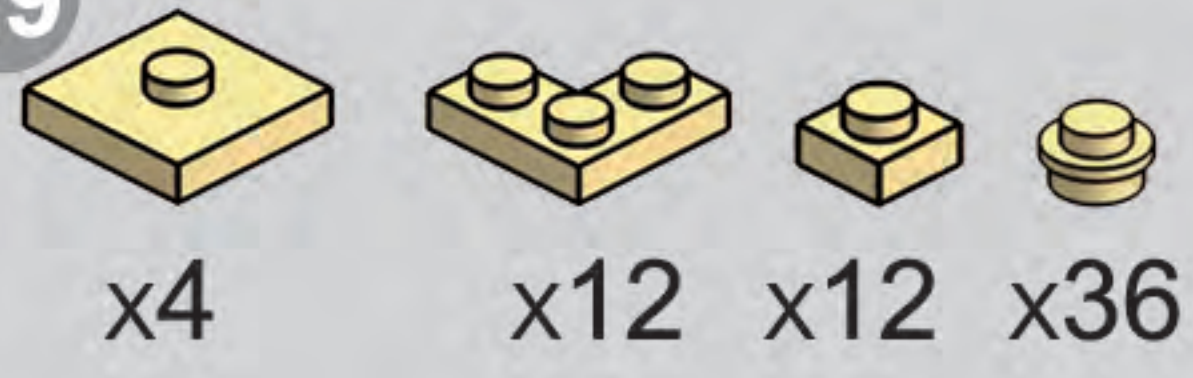

30

2 X 4

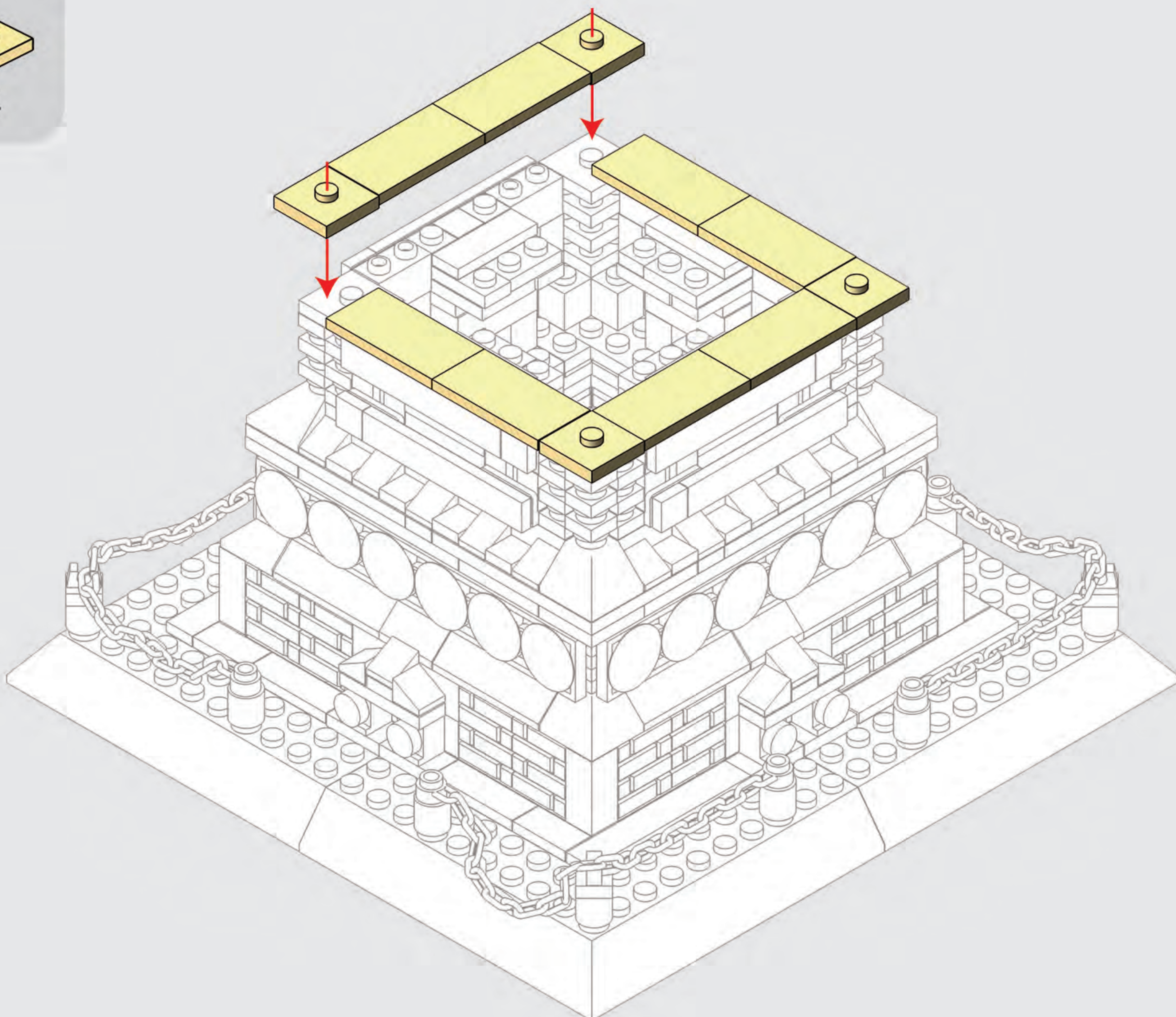
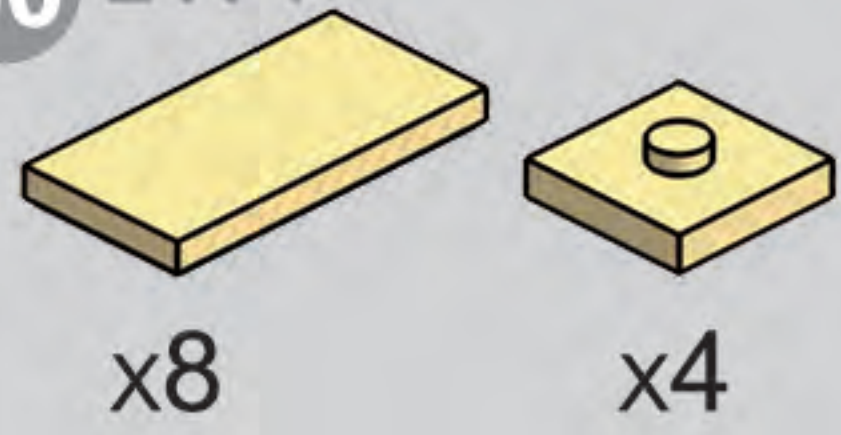

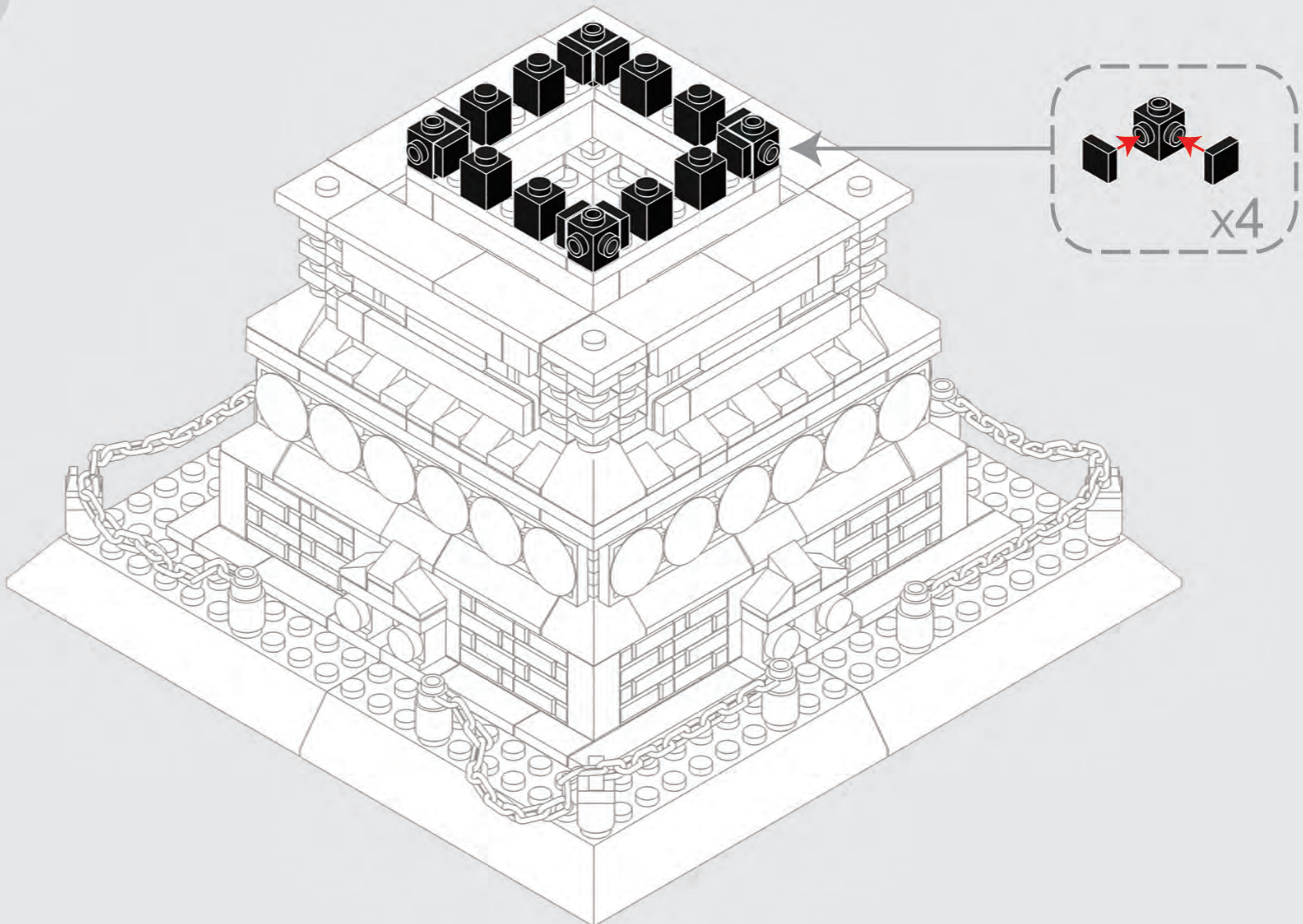
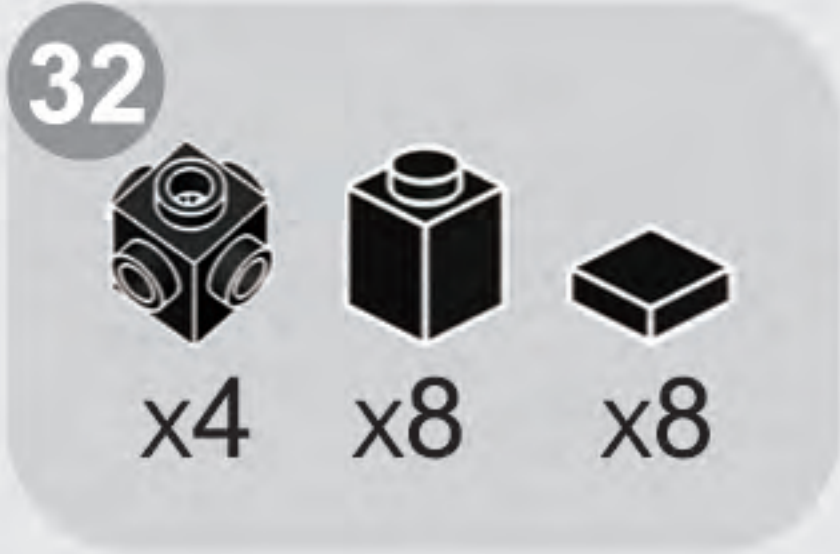
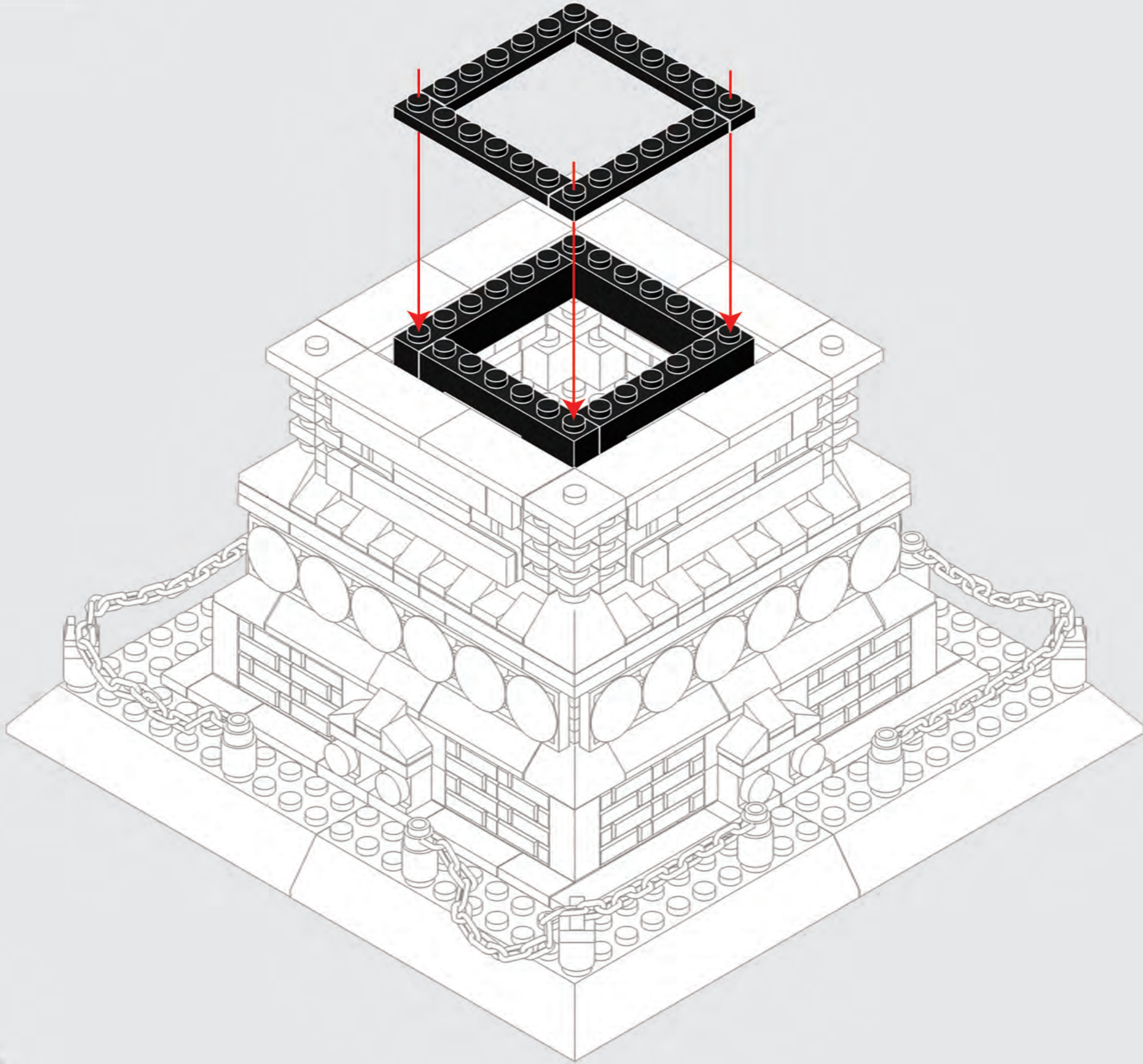
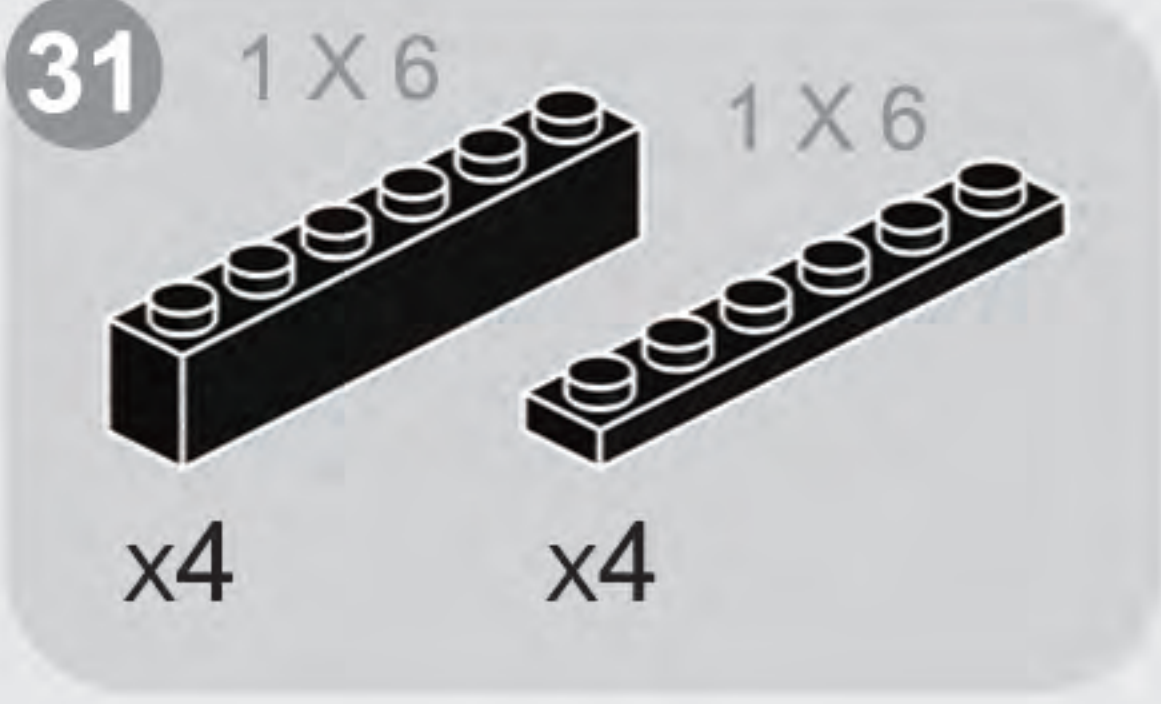

33 1 X 6
x8

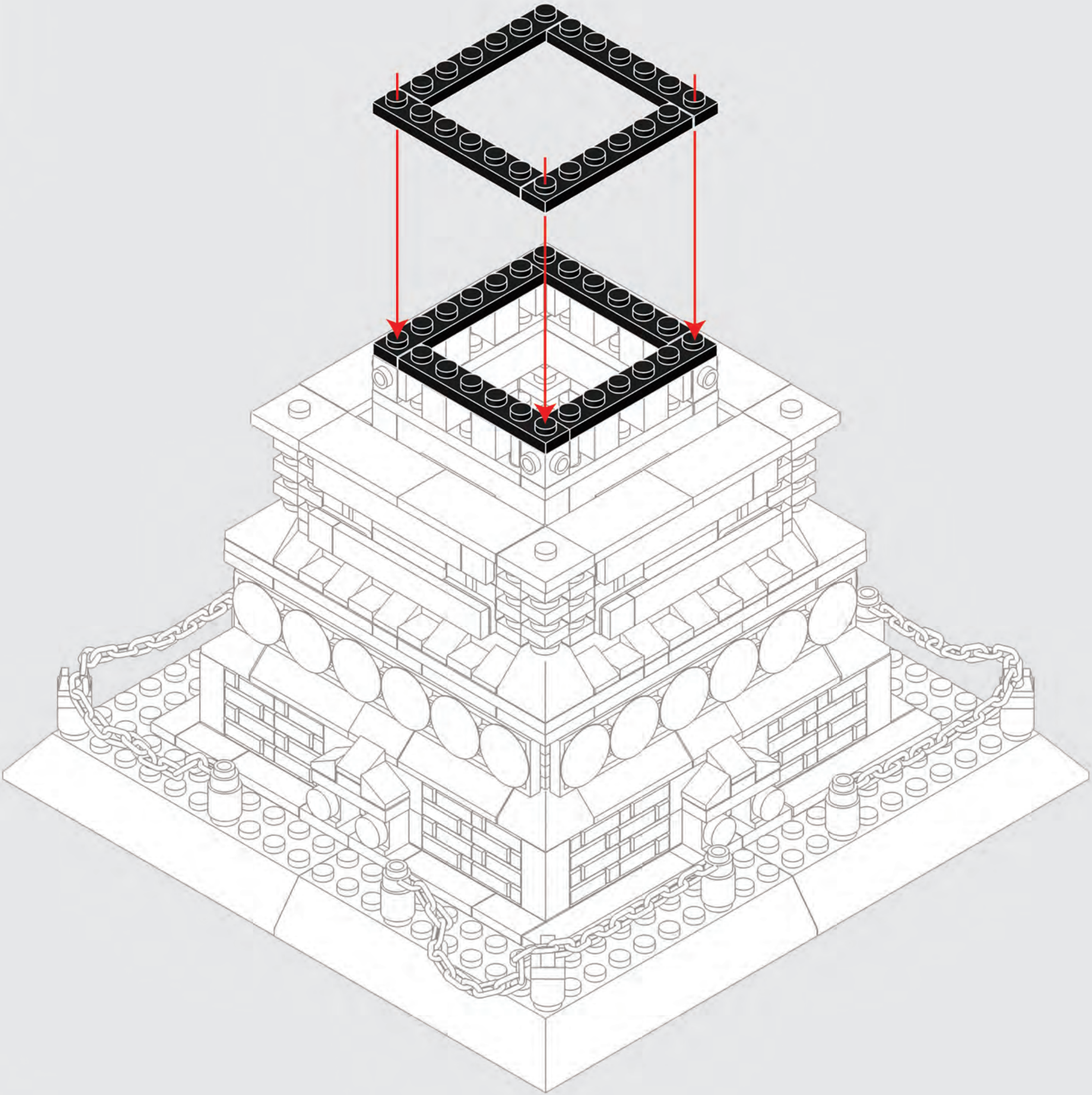

34
x4 x4

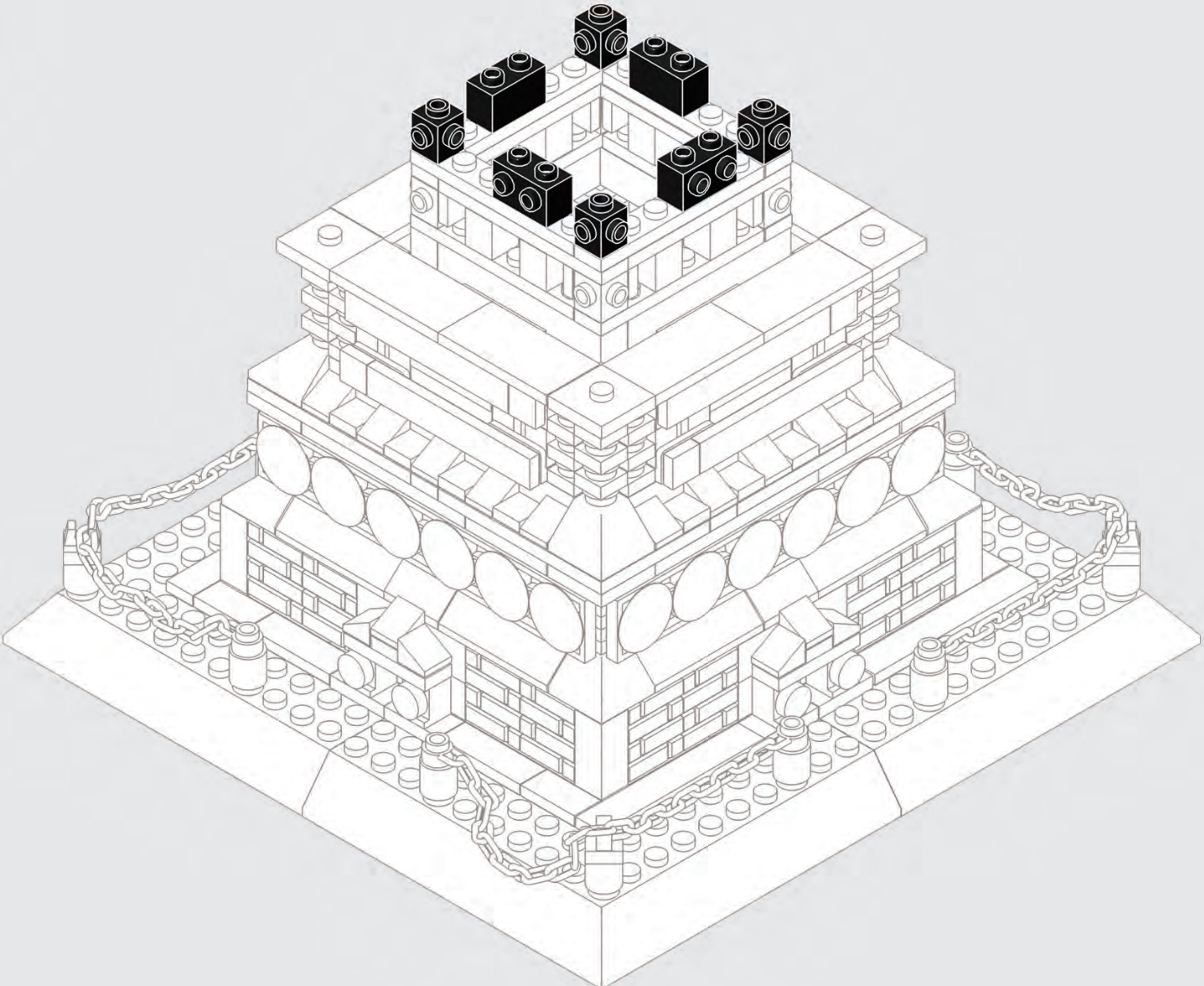

35 2 X 6



x4

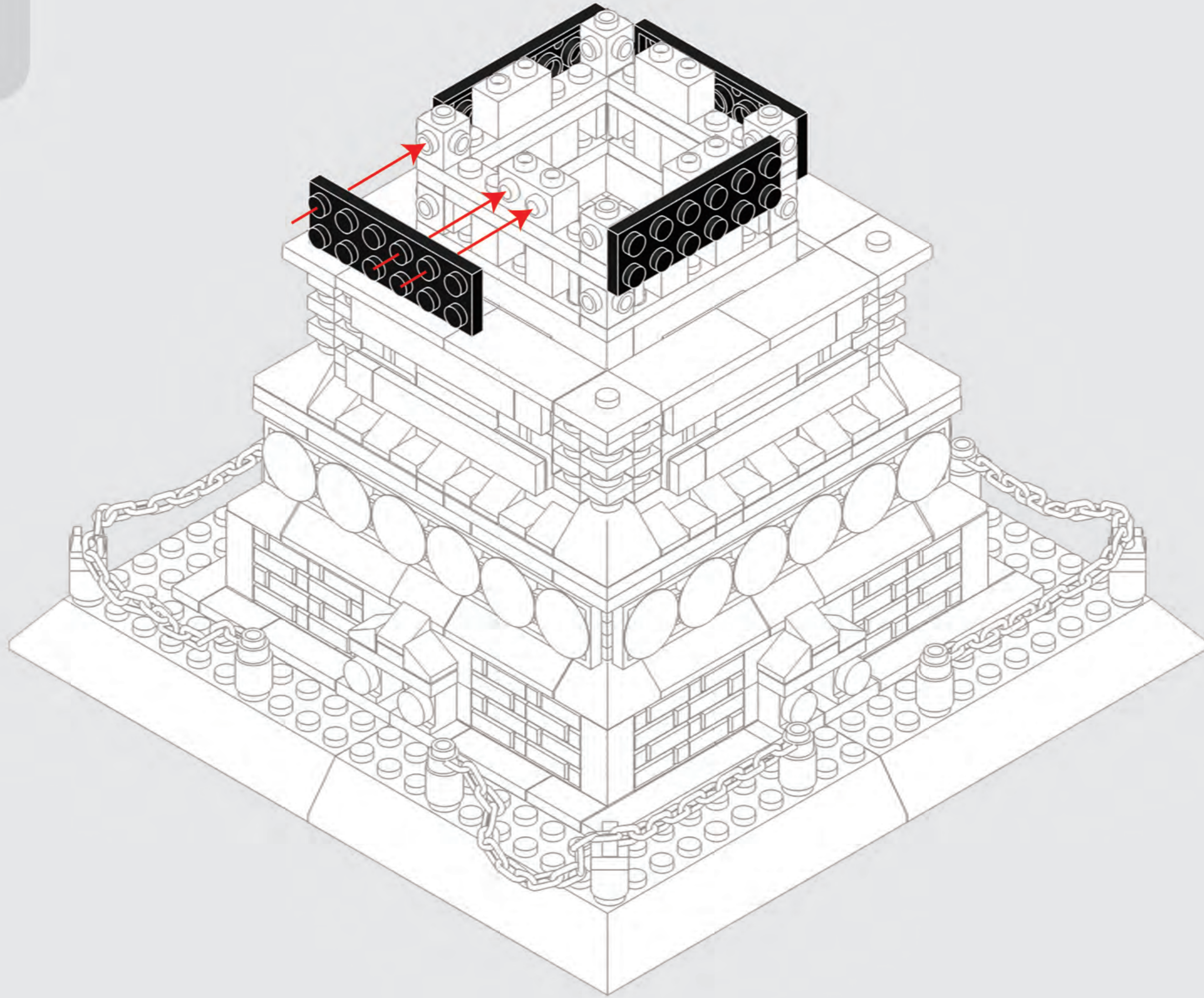

36

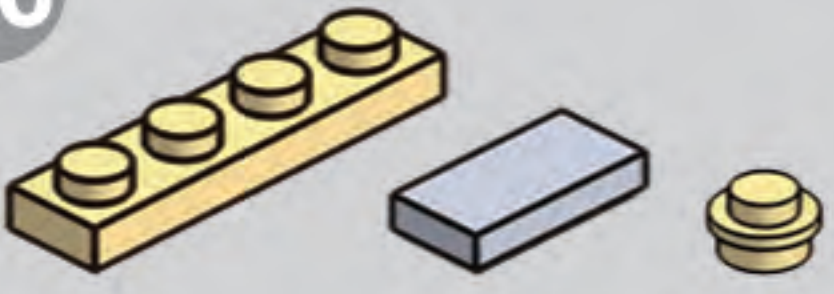

x2

x6

x8

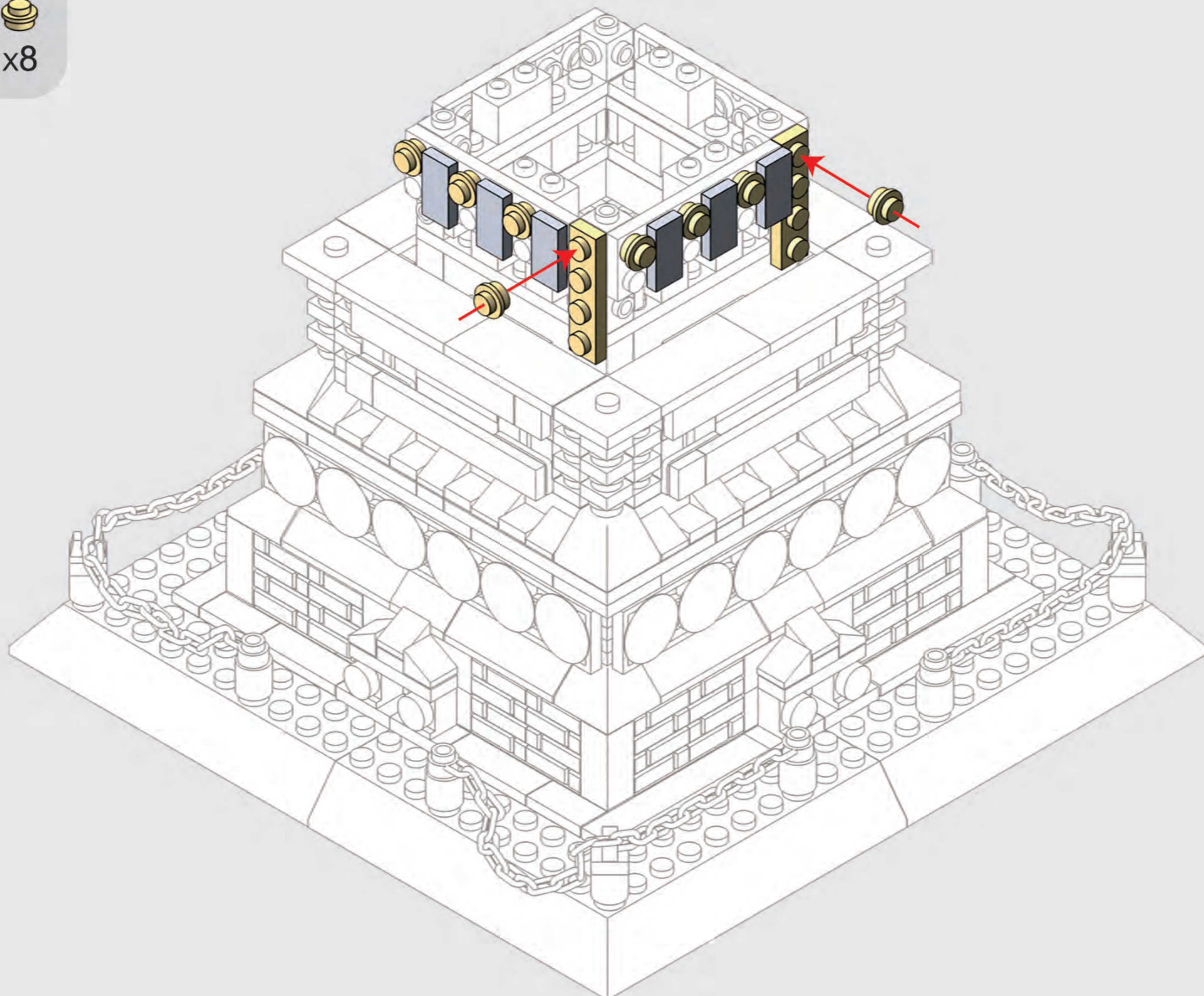

37

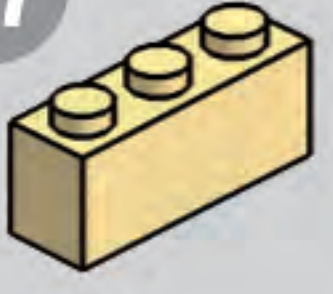

x8



x8

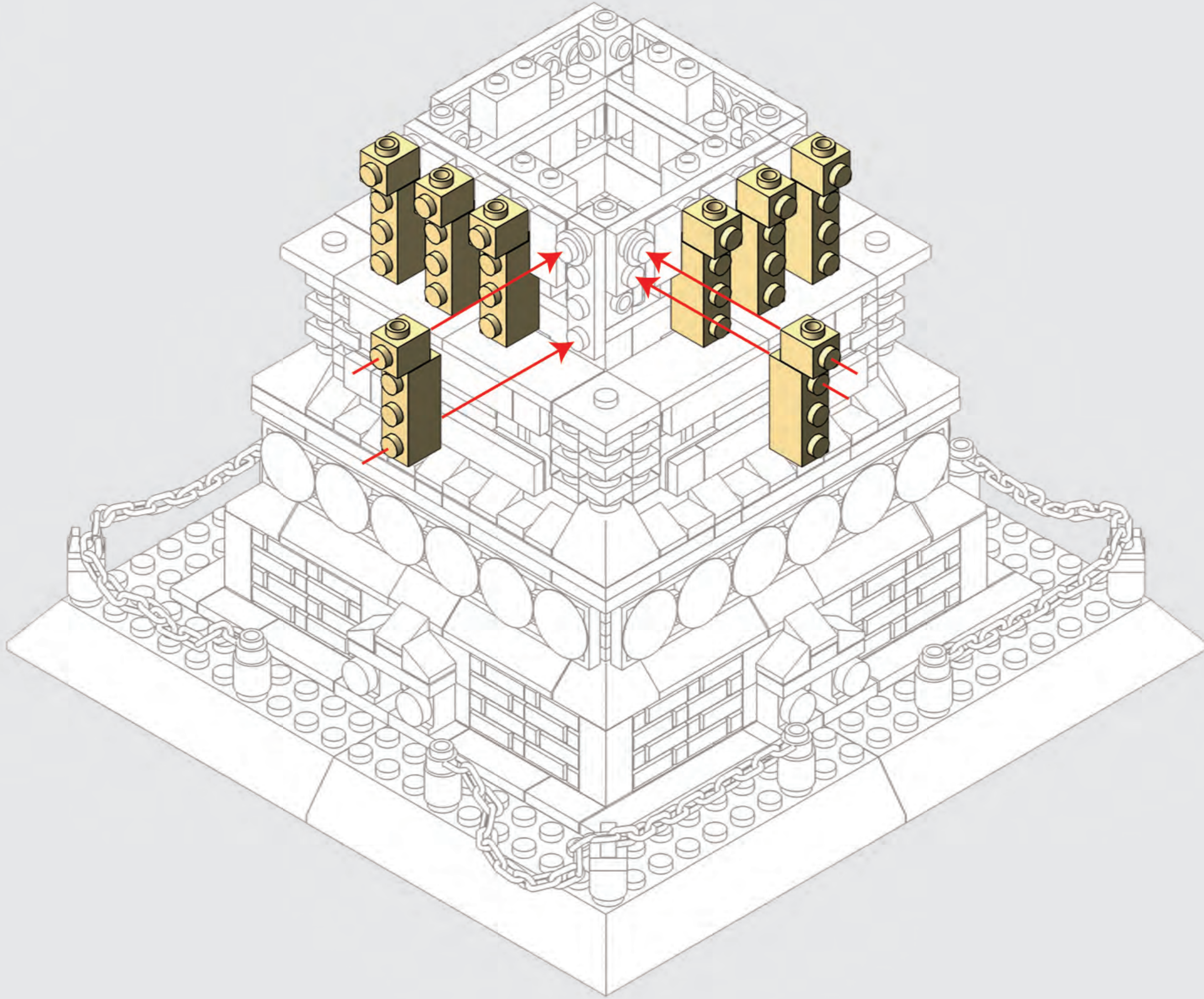

38

1 X 6

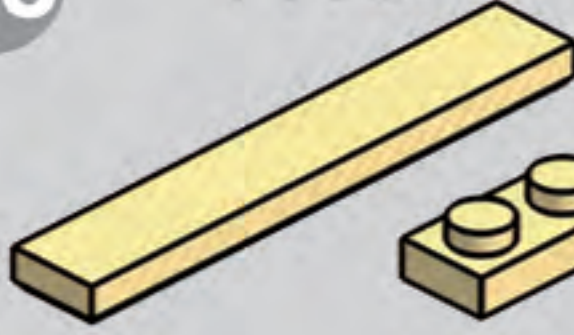

x2



x8



x2

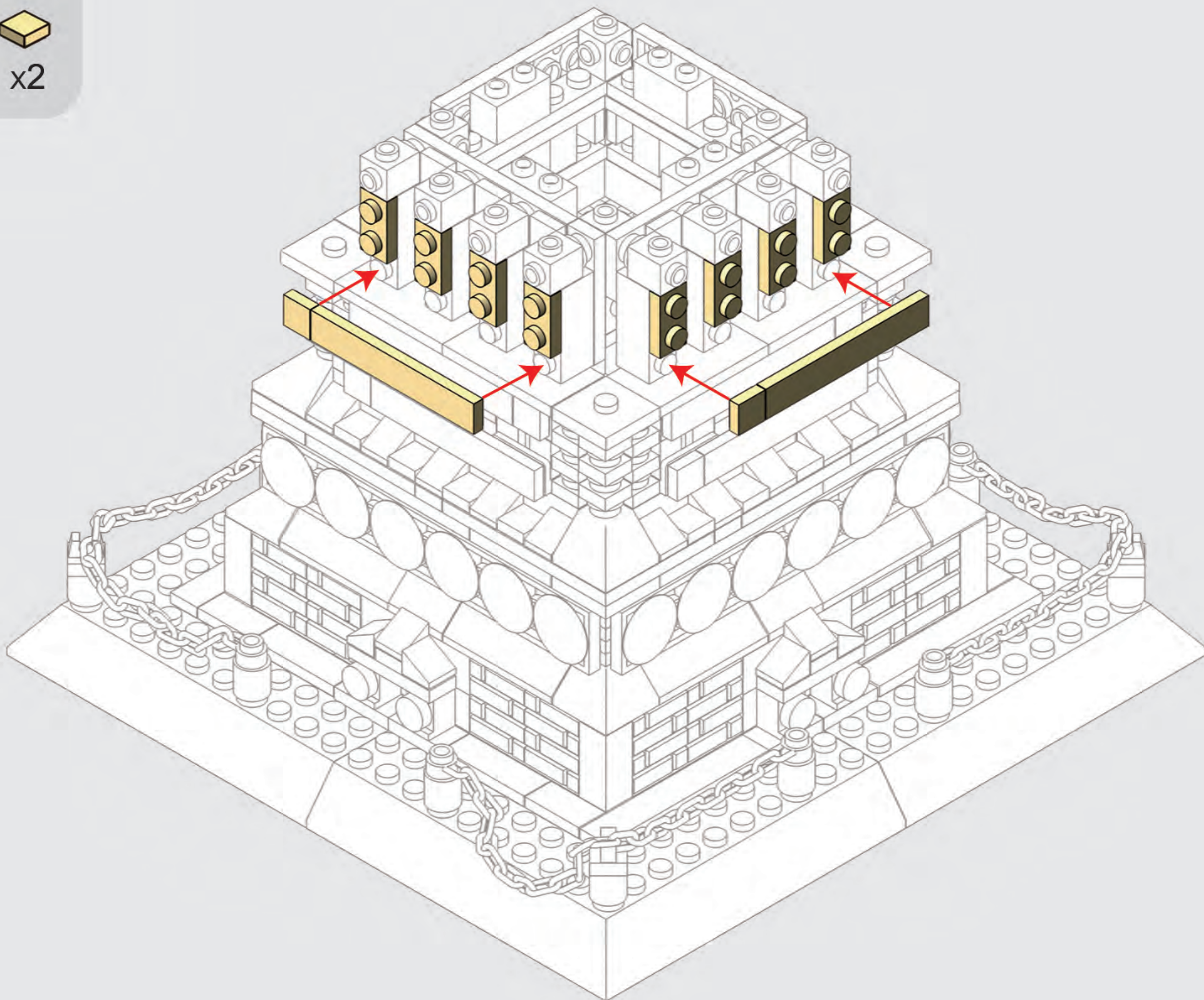

39



x16

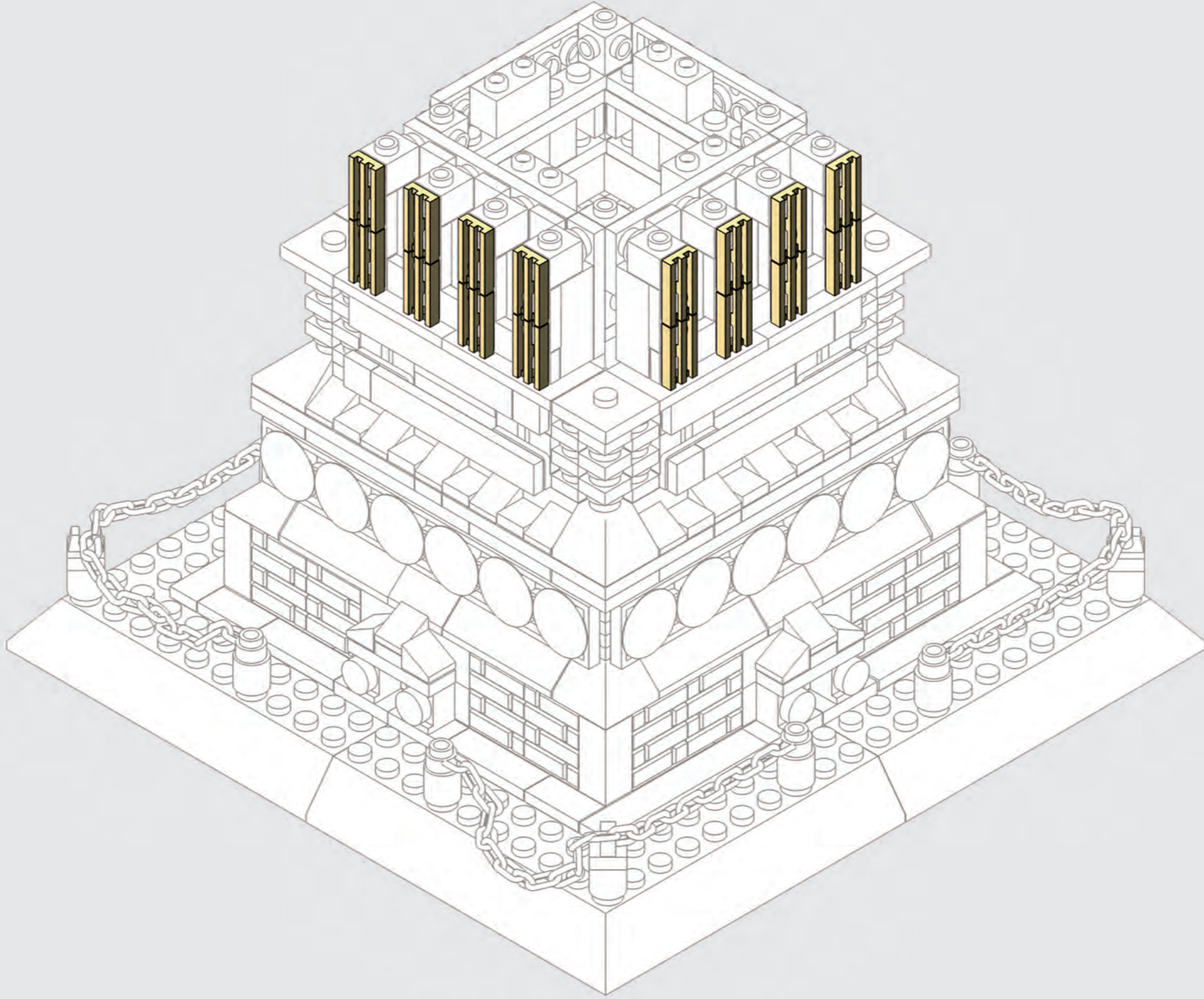

40

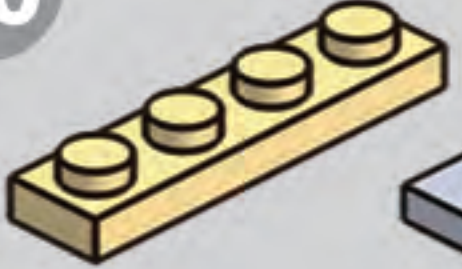

x2



x6



x8

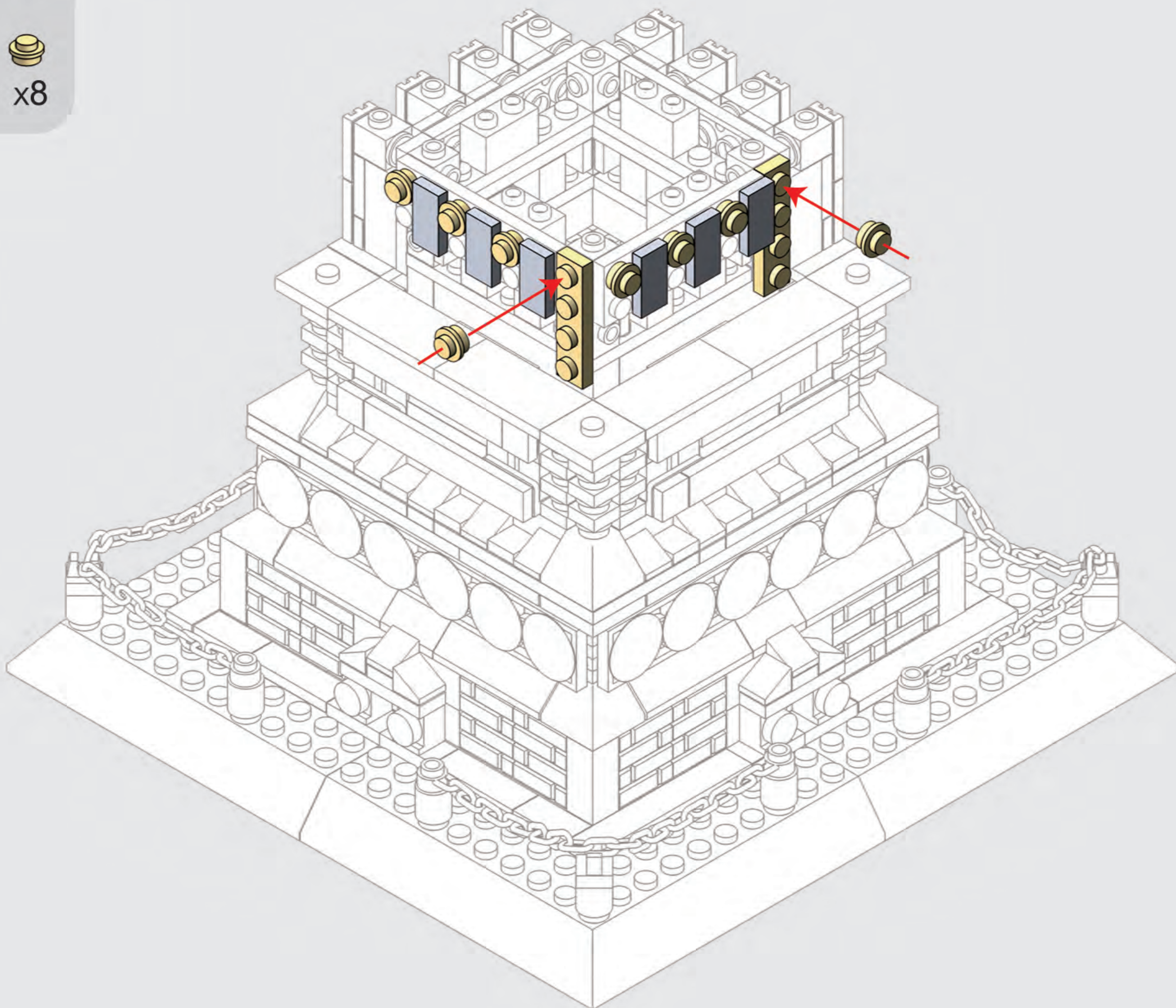
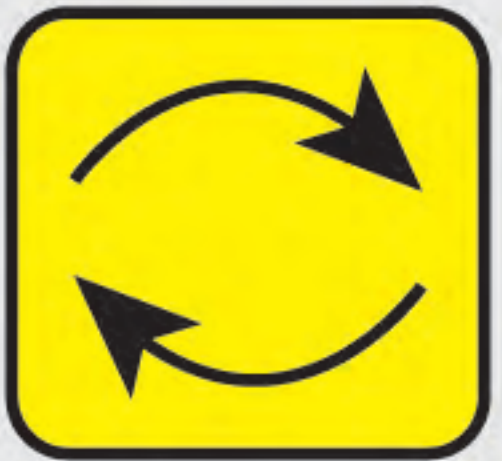

41

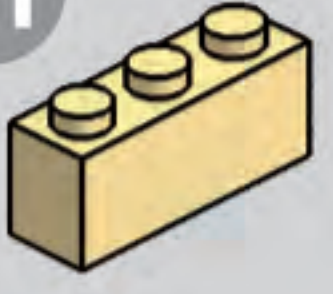

x8



x8

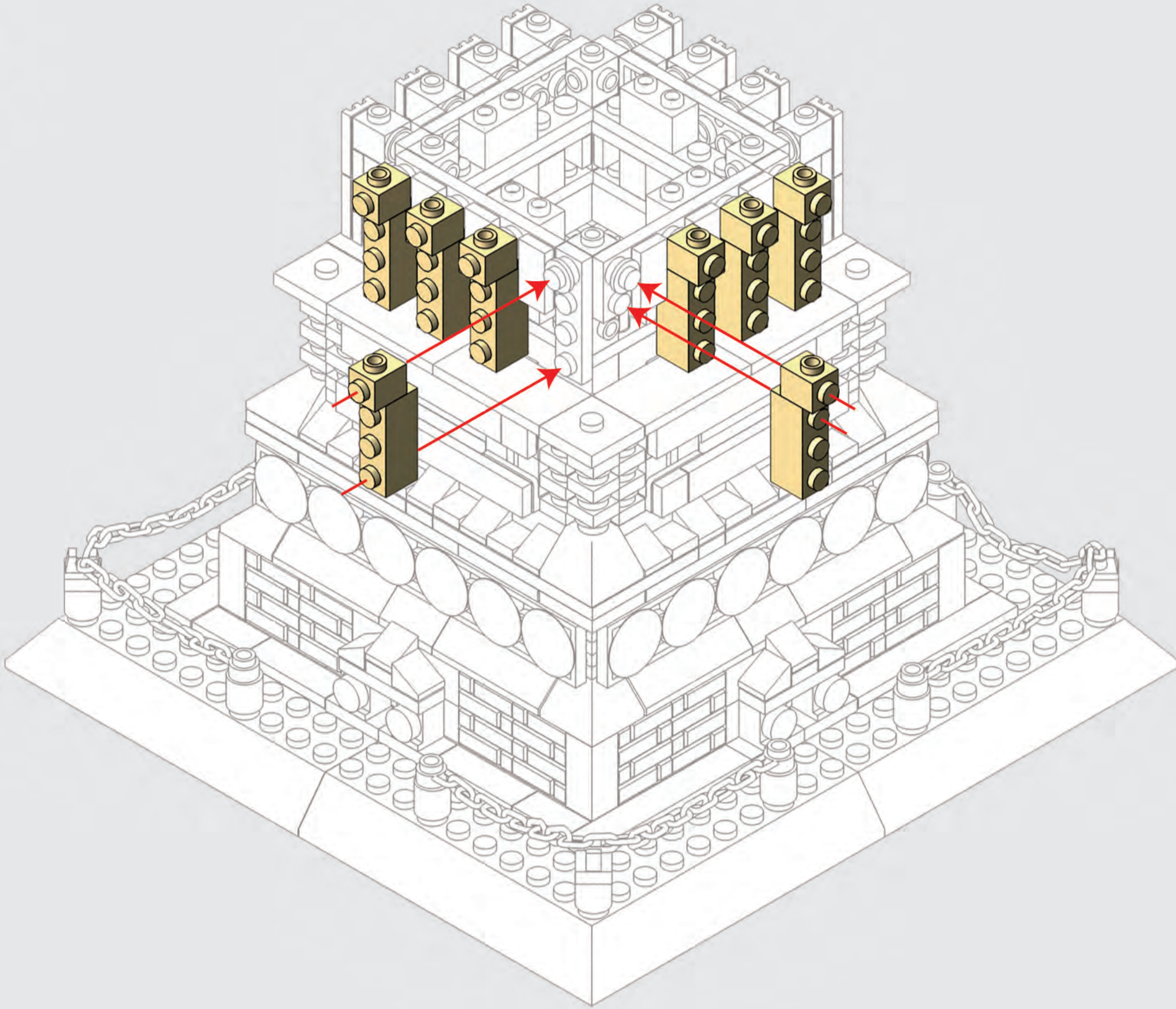

42

1 X 6

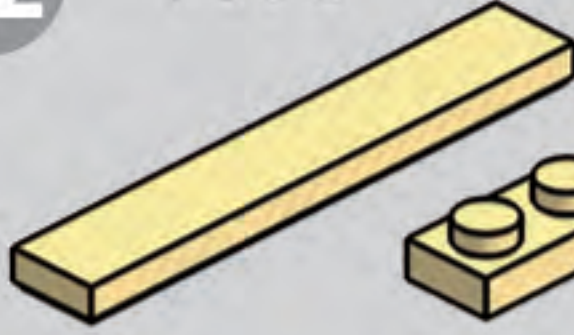

x2



x8



x2

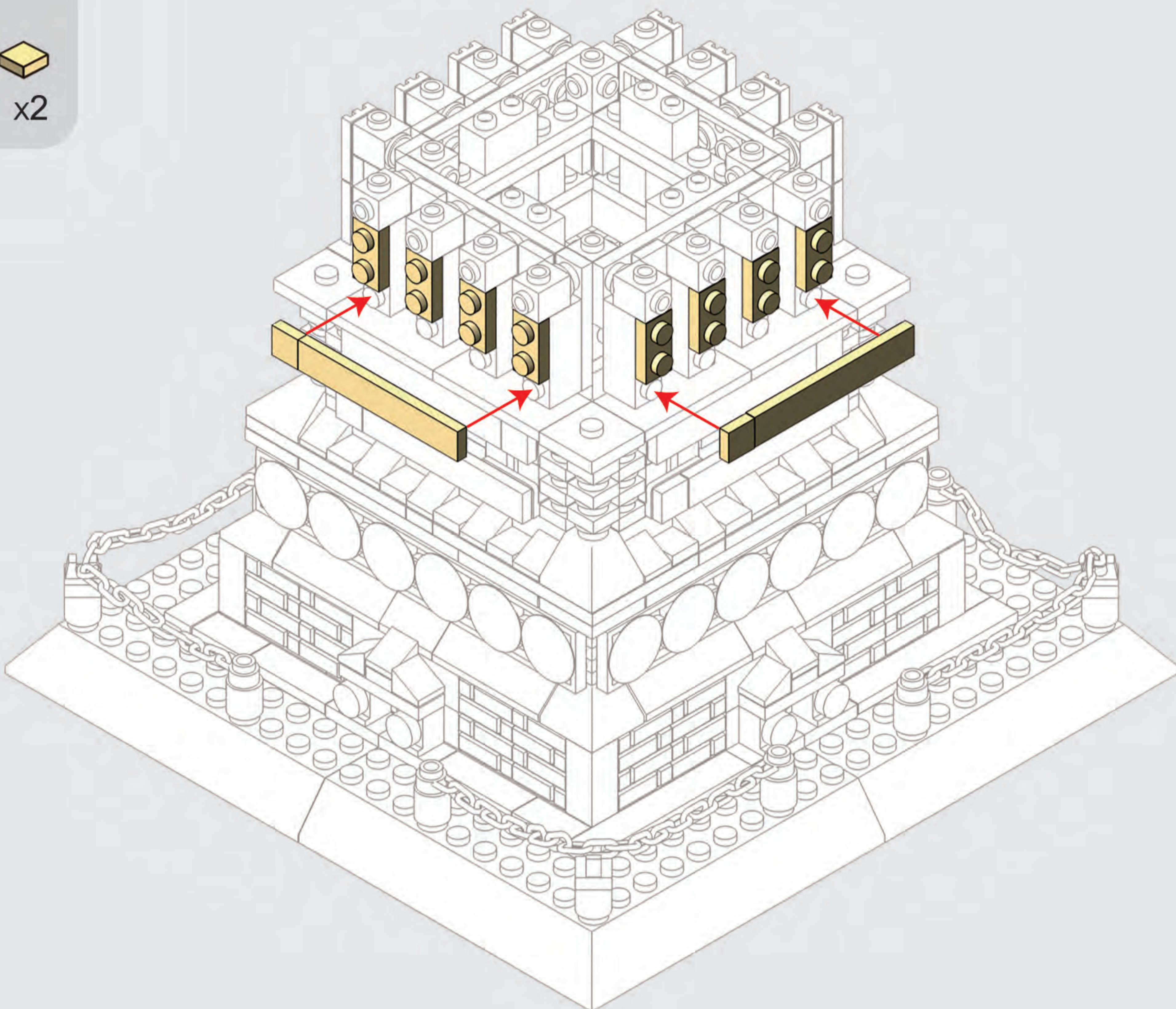

43



x16

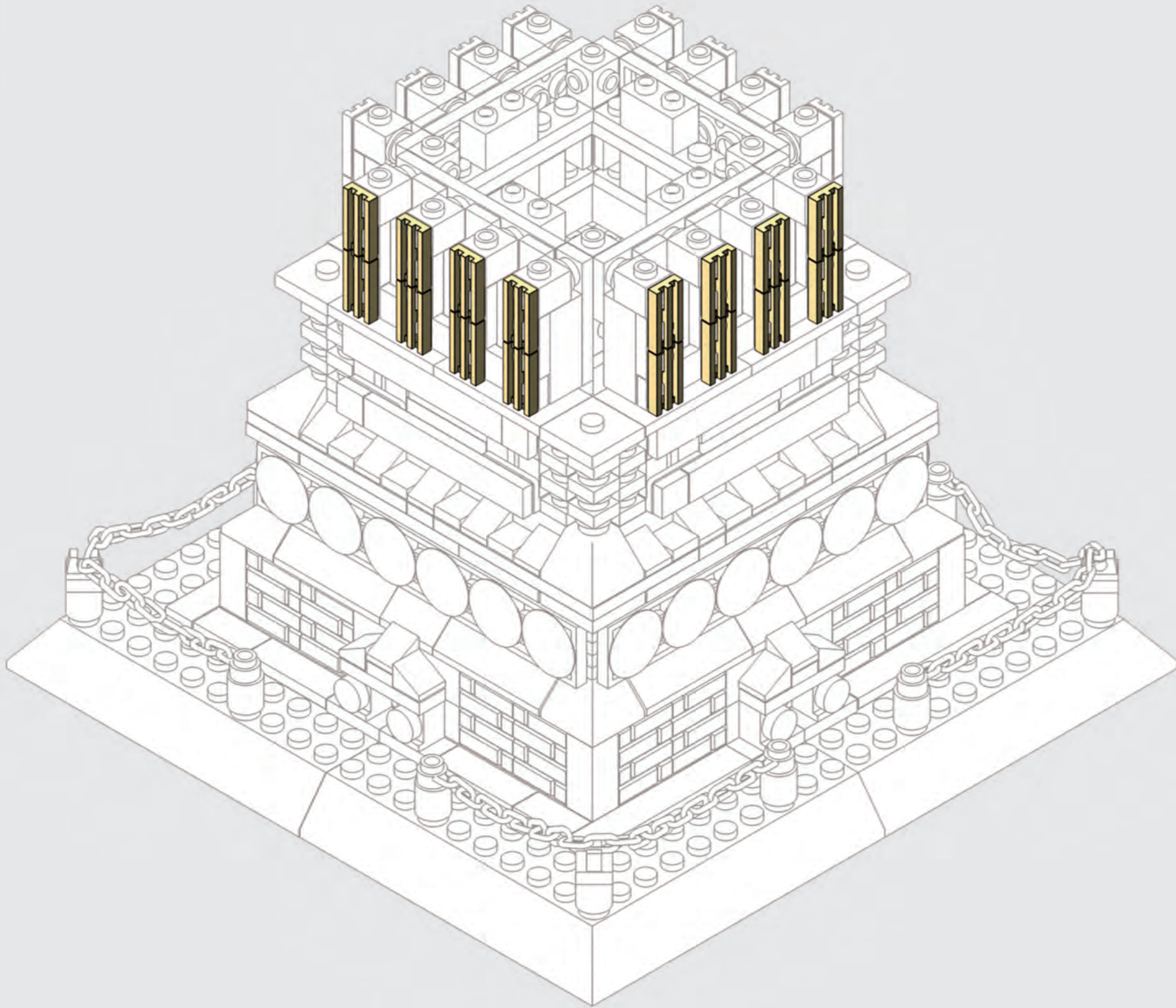

44



x16

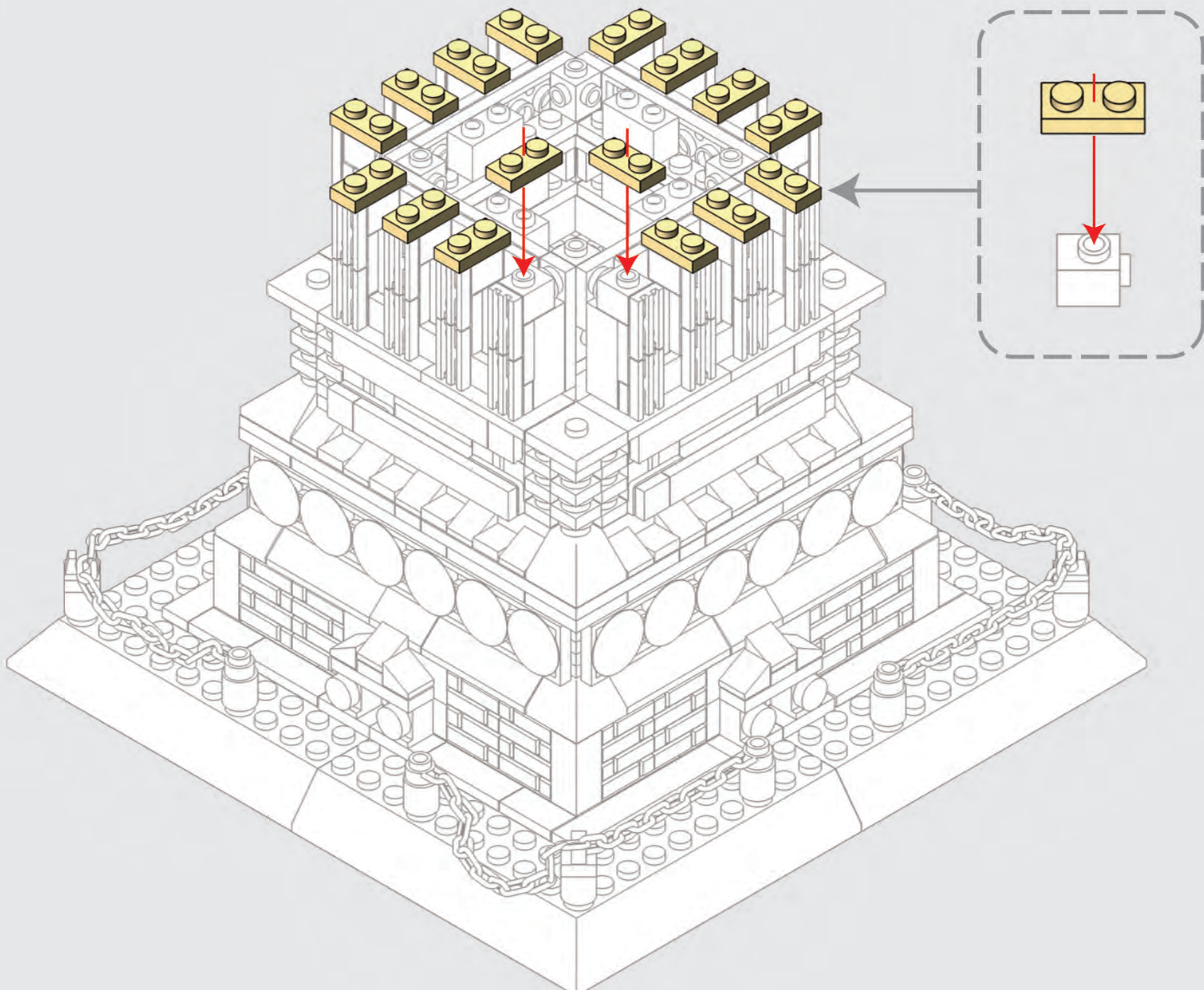

45



x8



x20



x20



x60

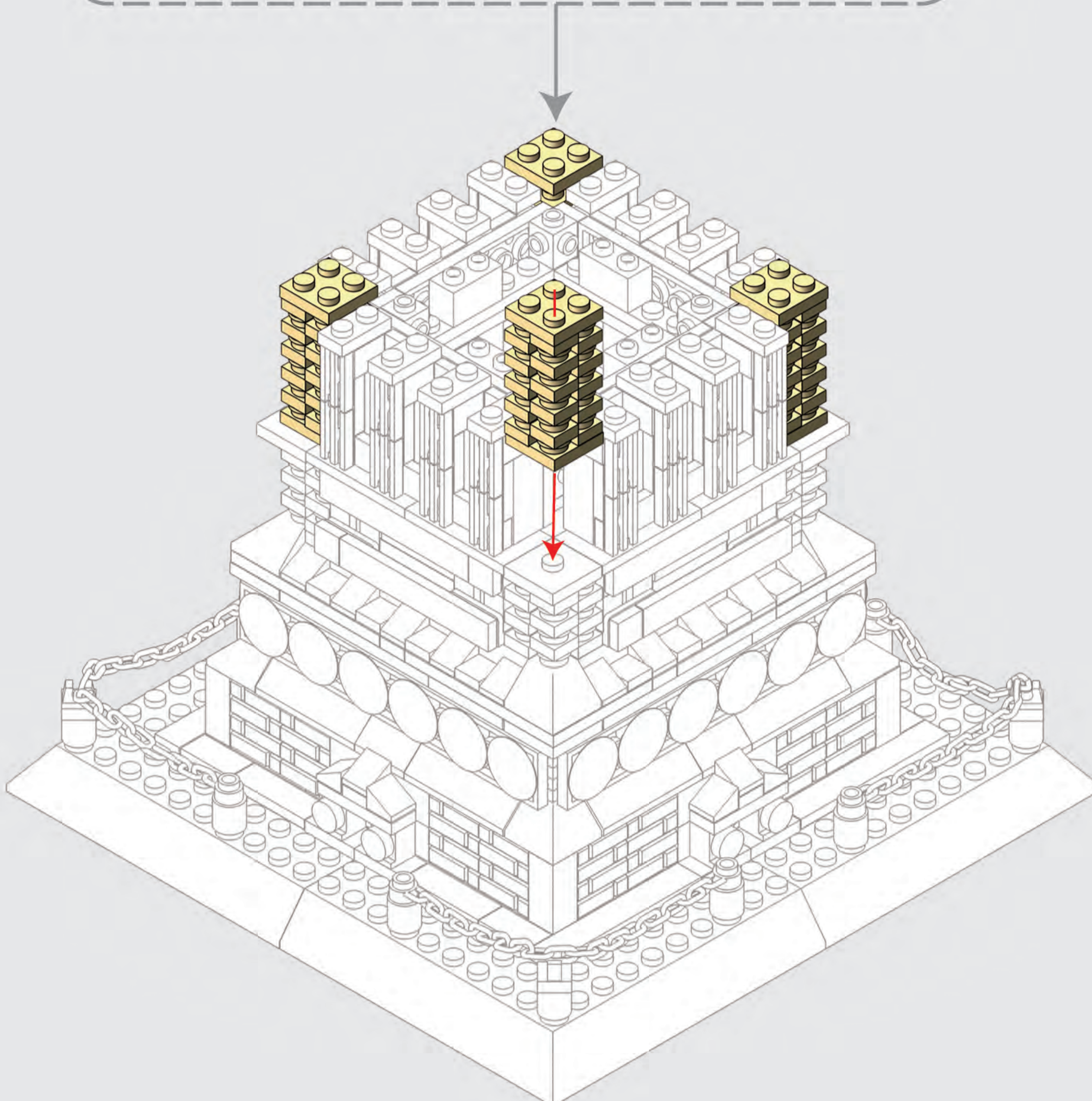
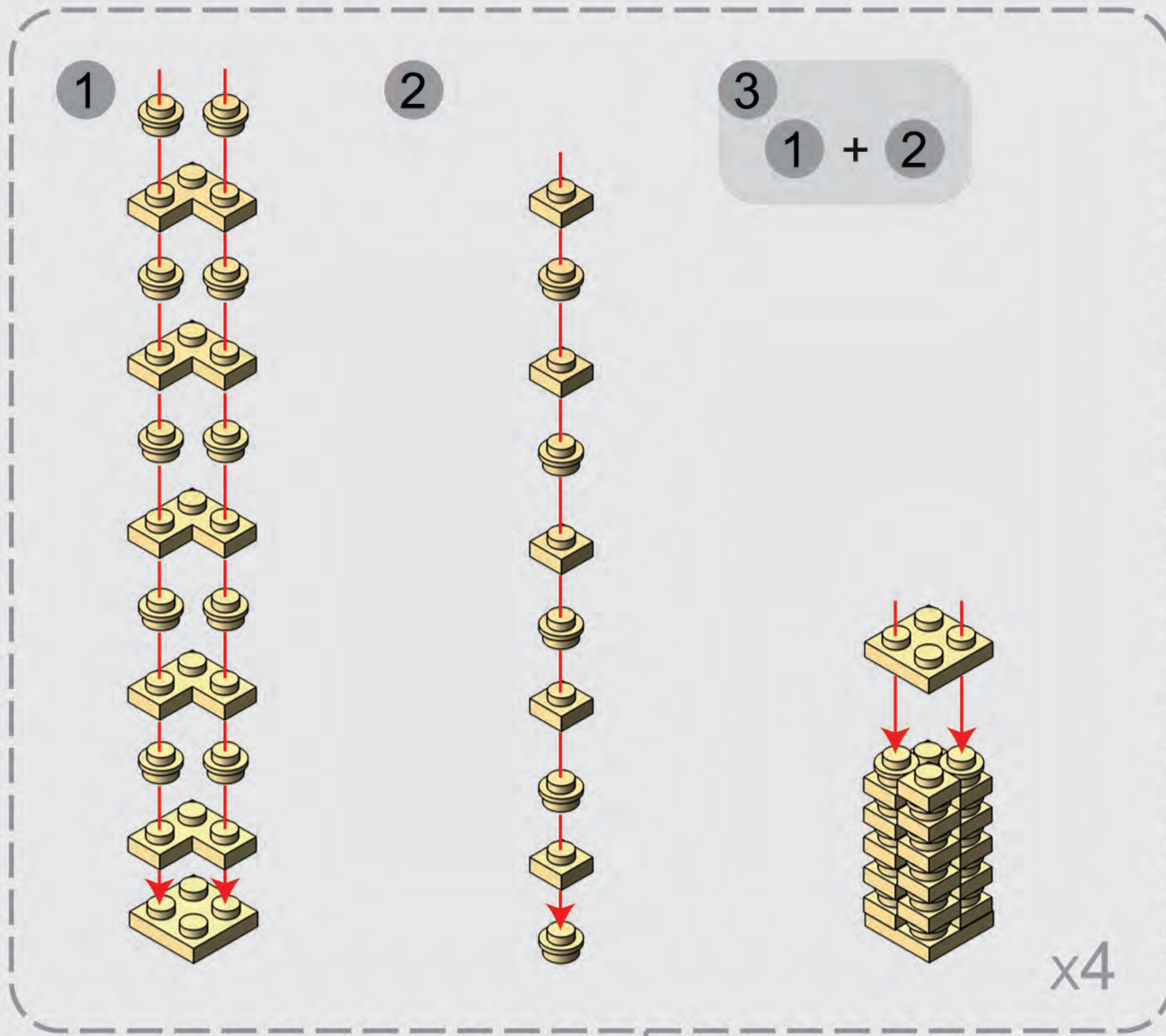

46

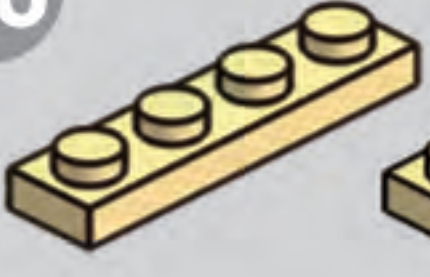

x4

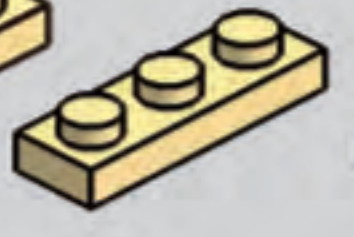

x4



x28

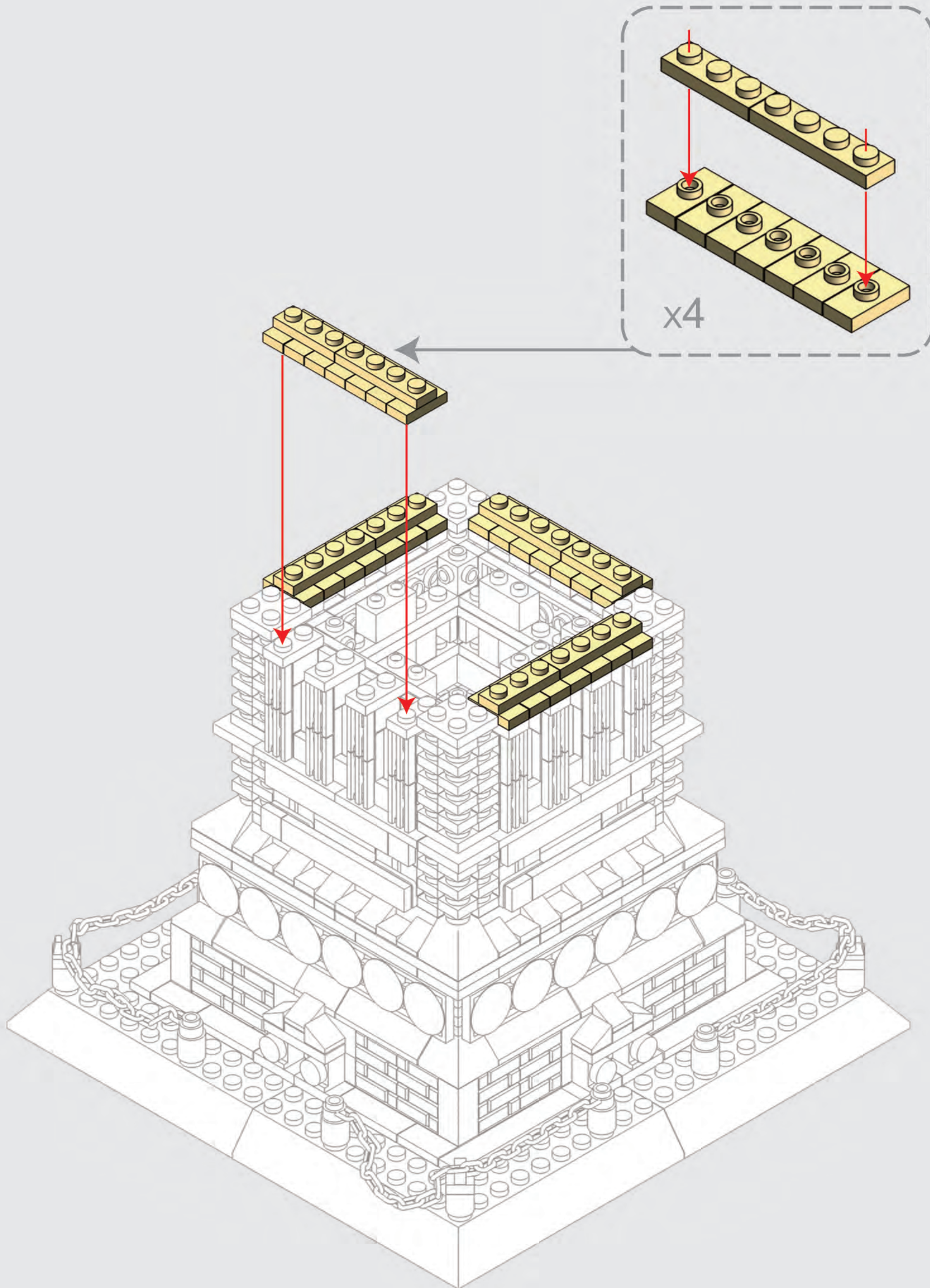

47

1 X 6



x4

x4

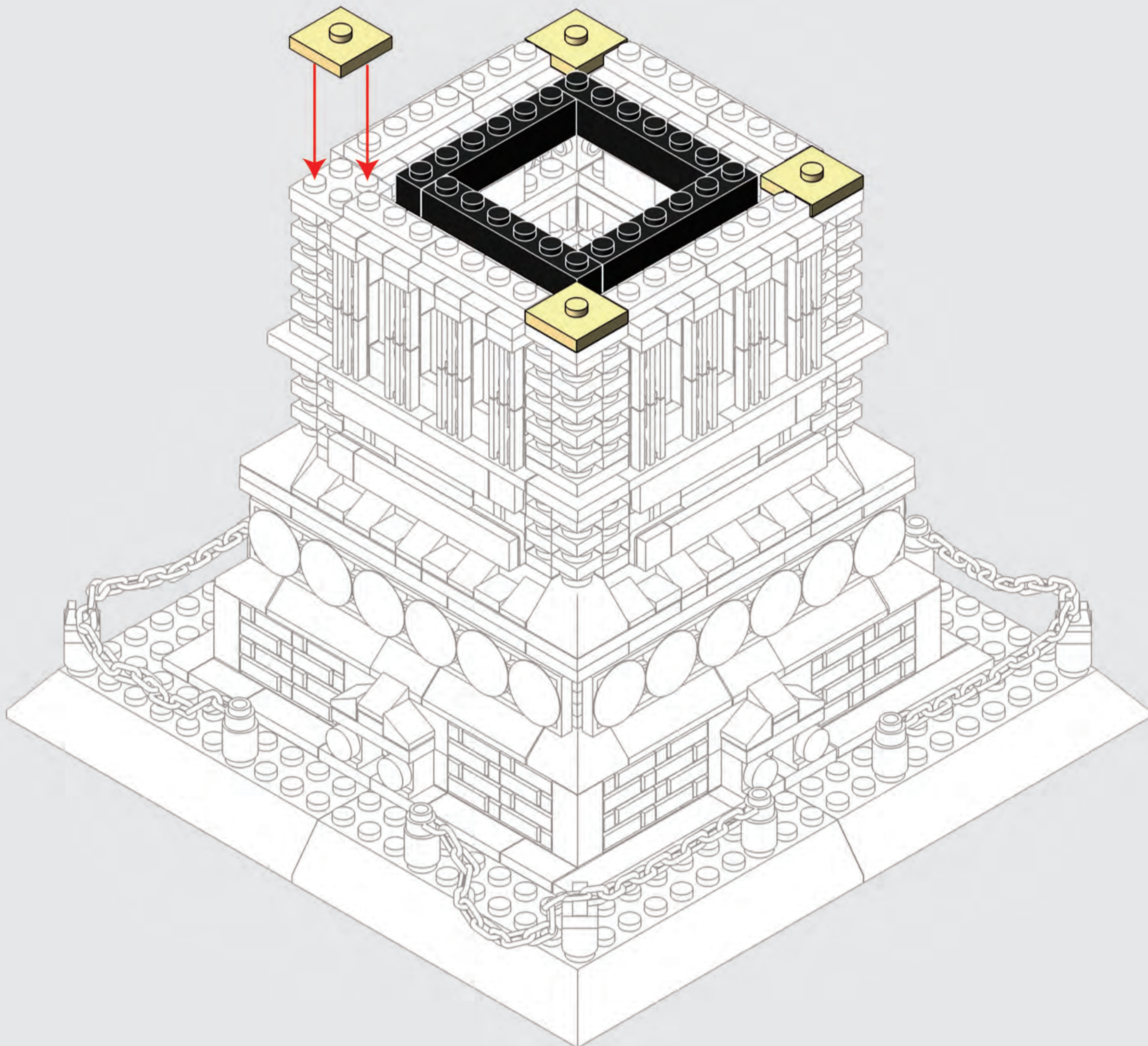

48

2 X 10

1 X 6

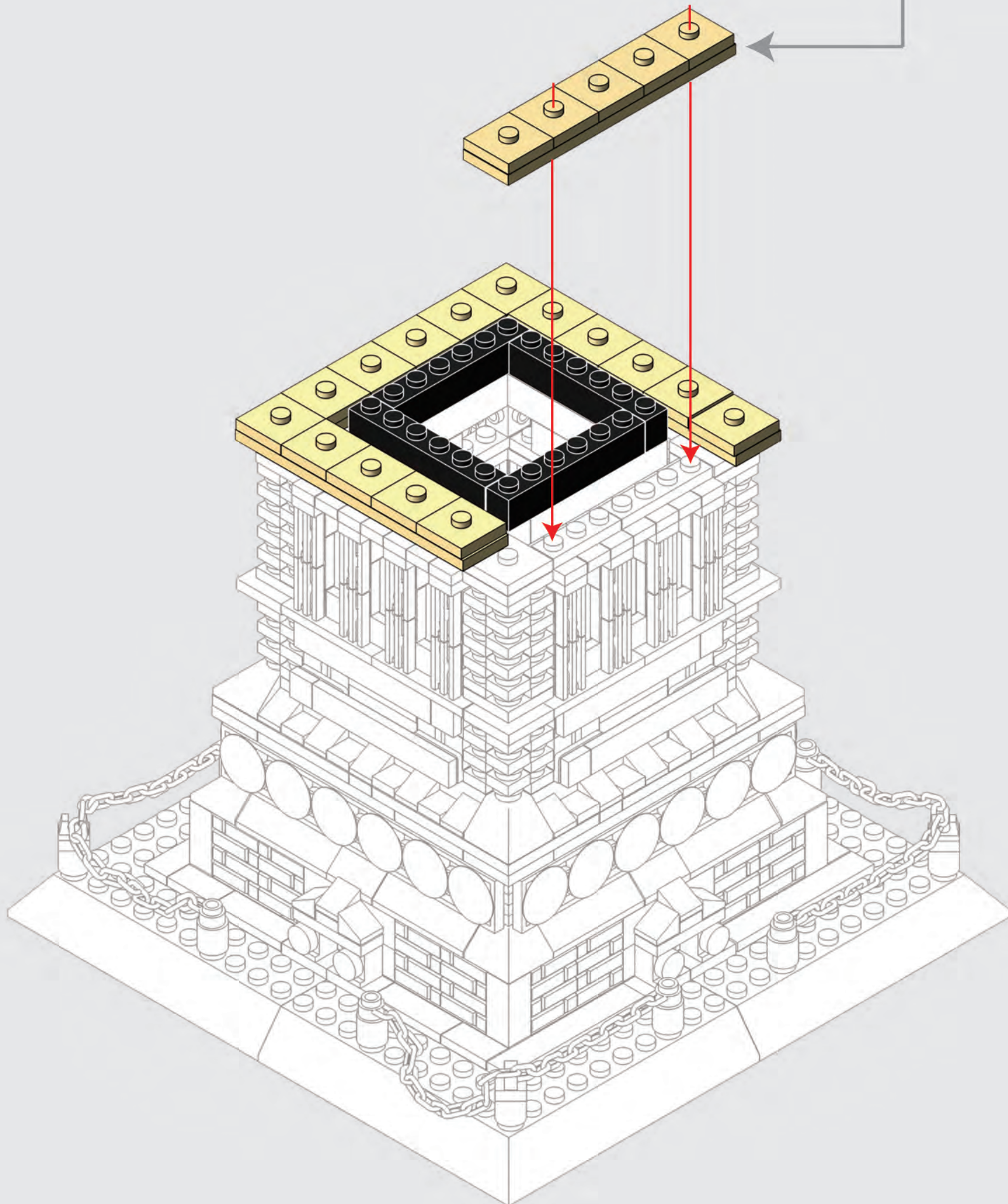
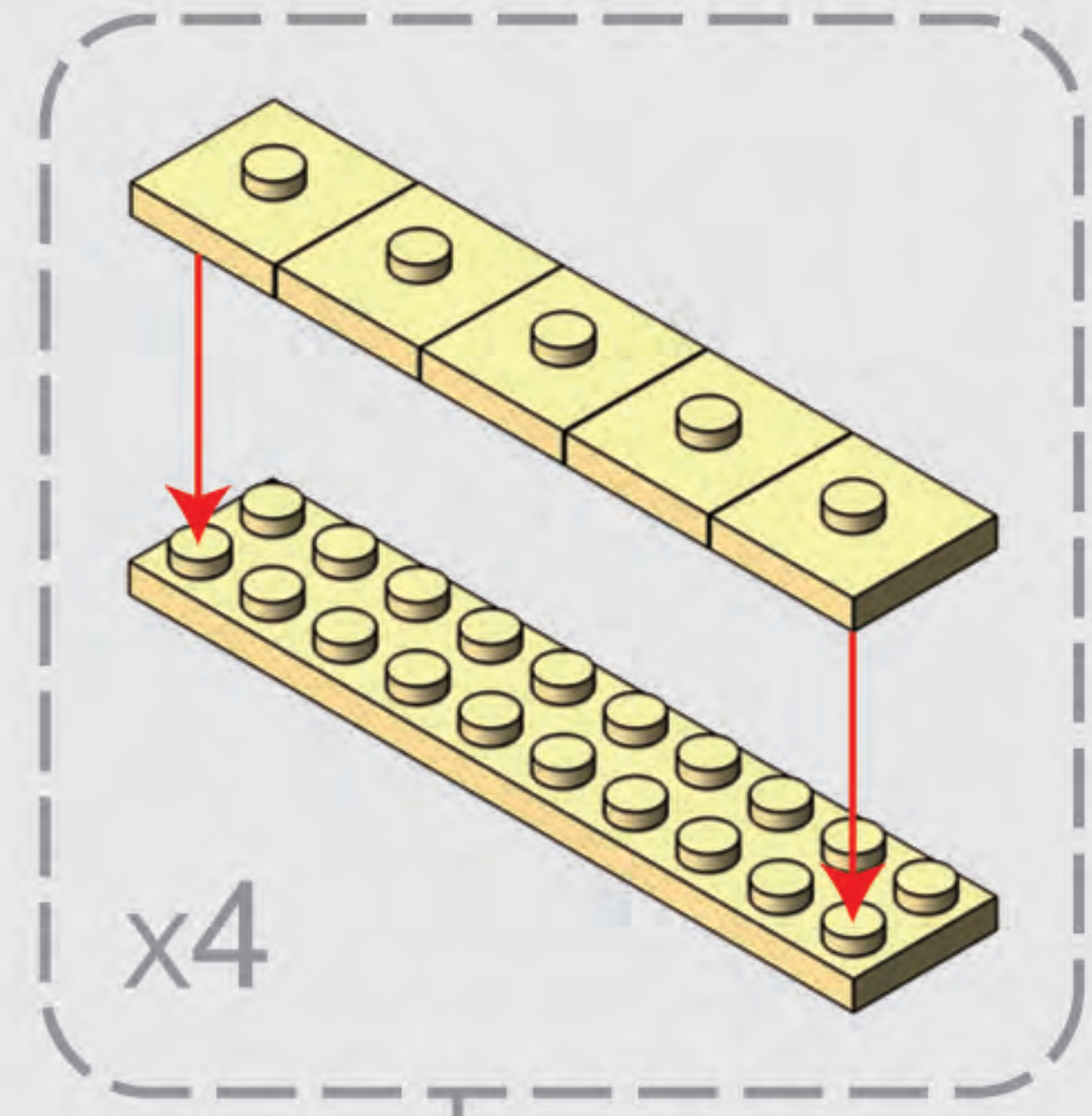
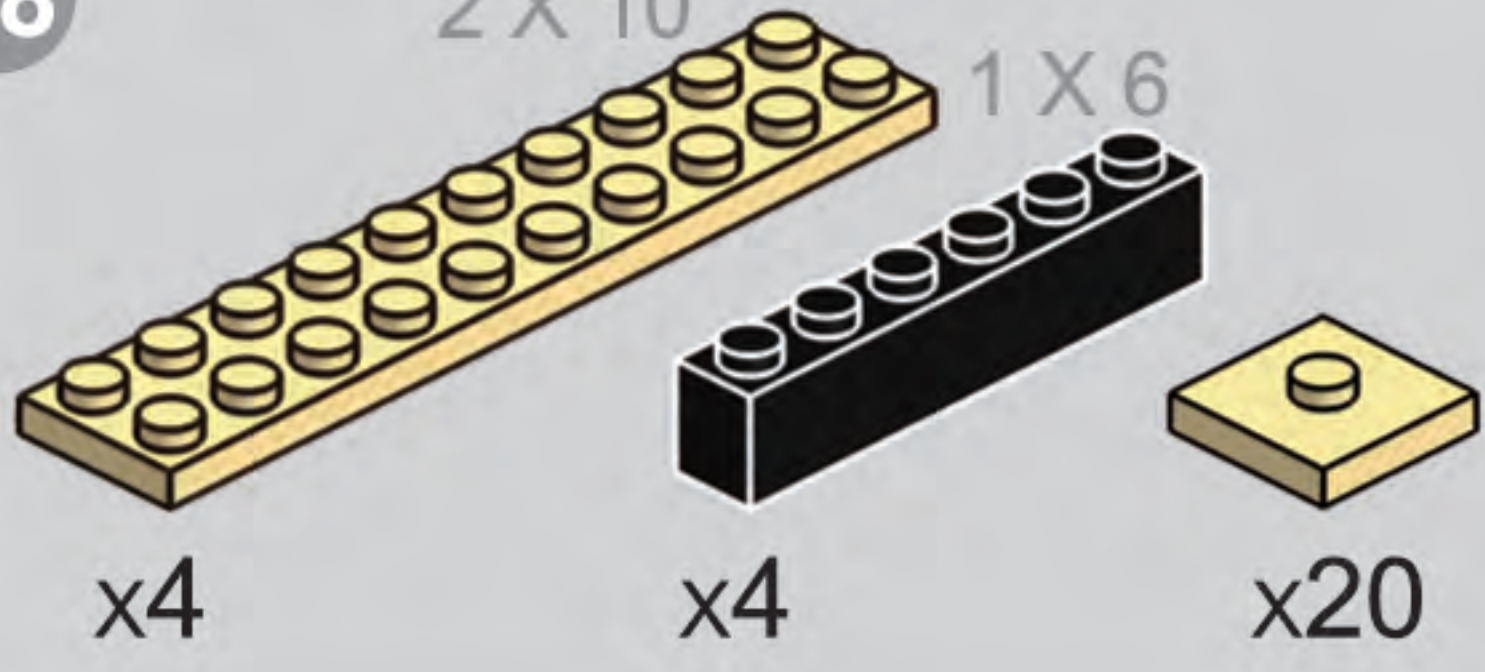

49

2 X 8

4 X 6

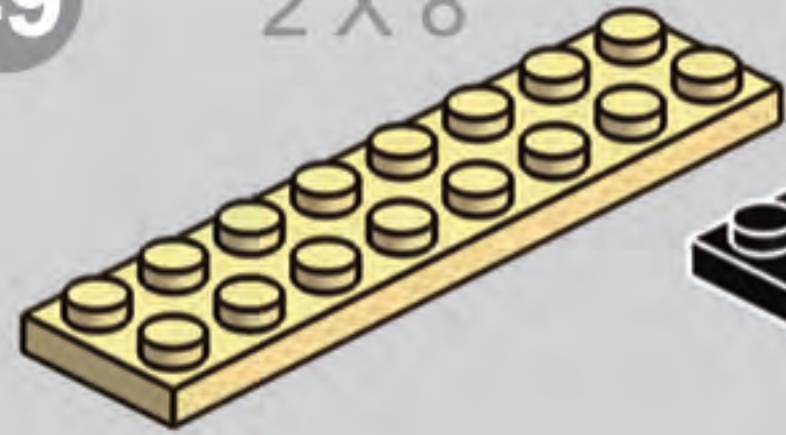

x4

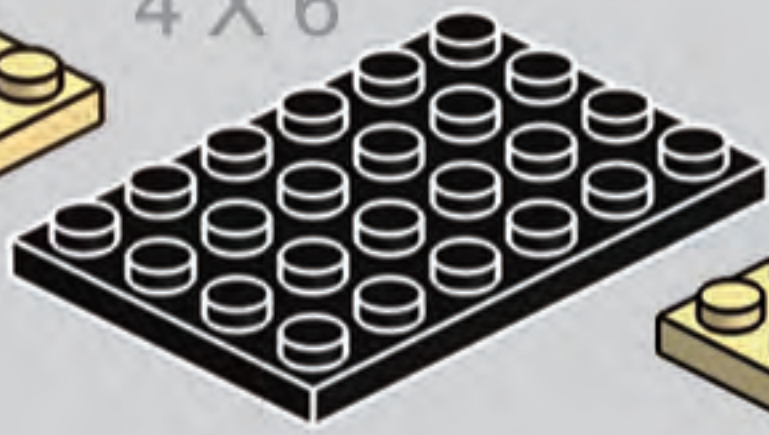

x4



x4



x4

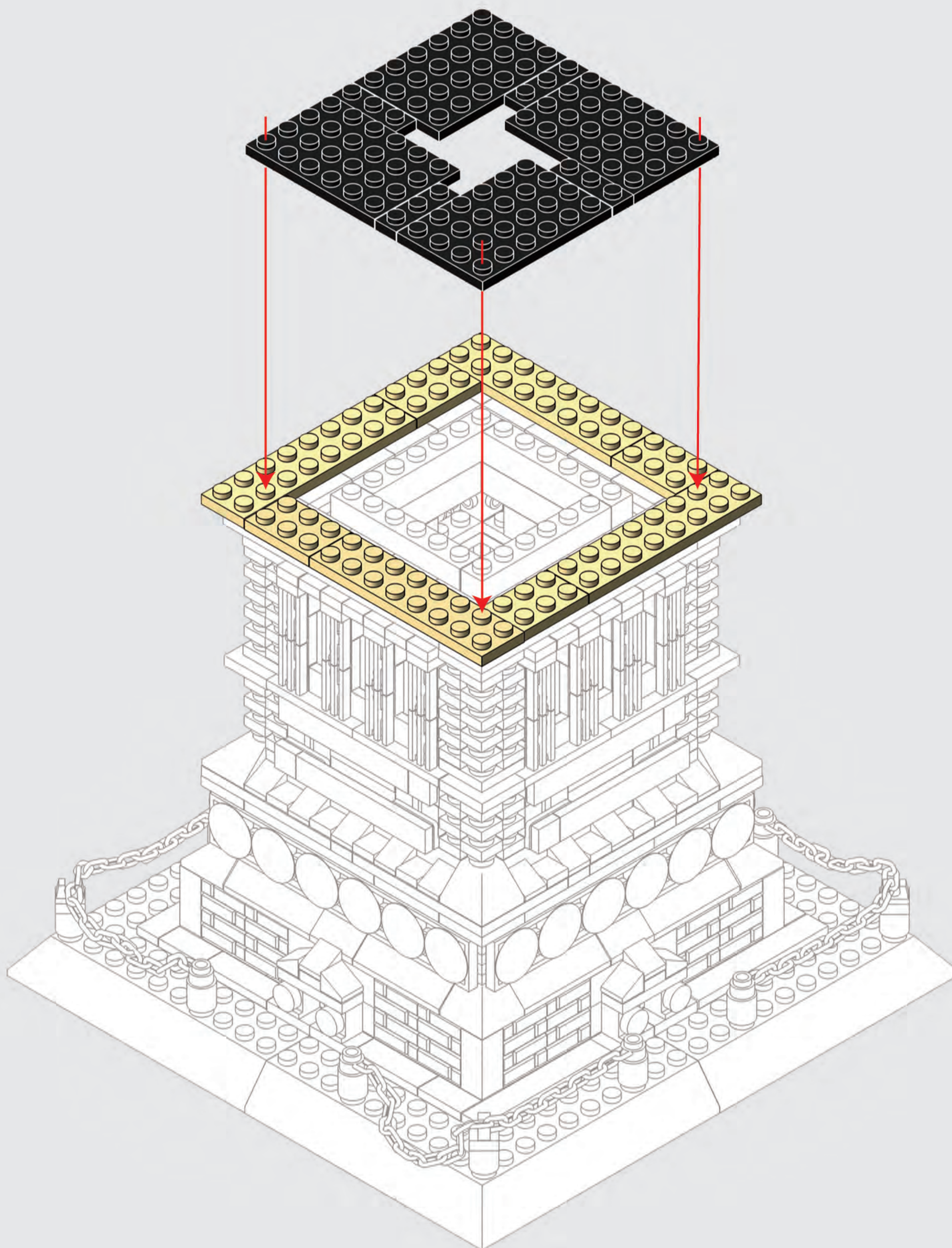

50



x4



x16



x4



x4

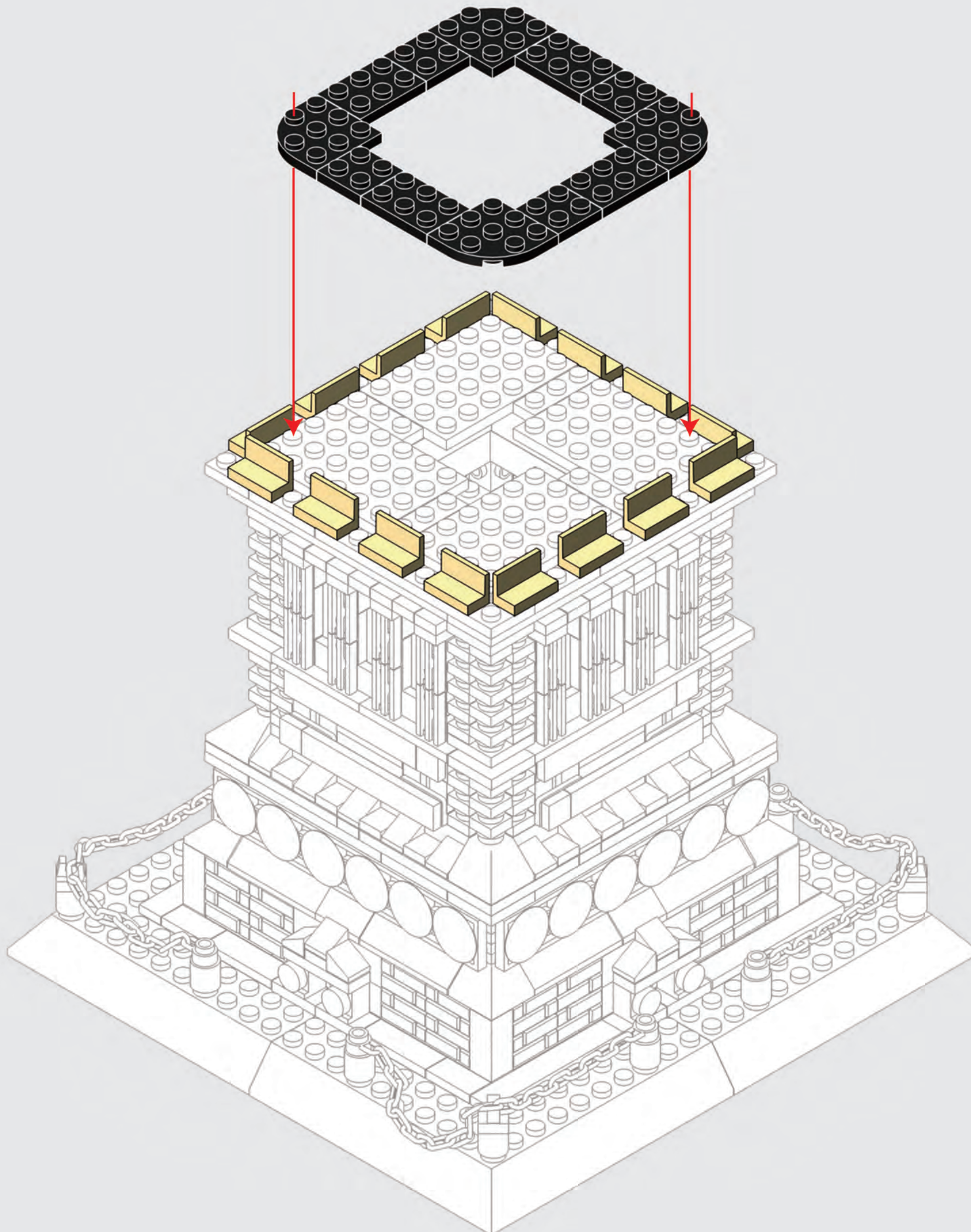

51



x6

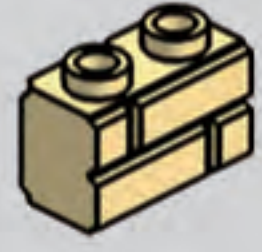

x8



x4



x12



x36

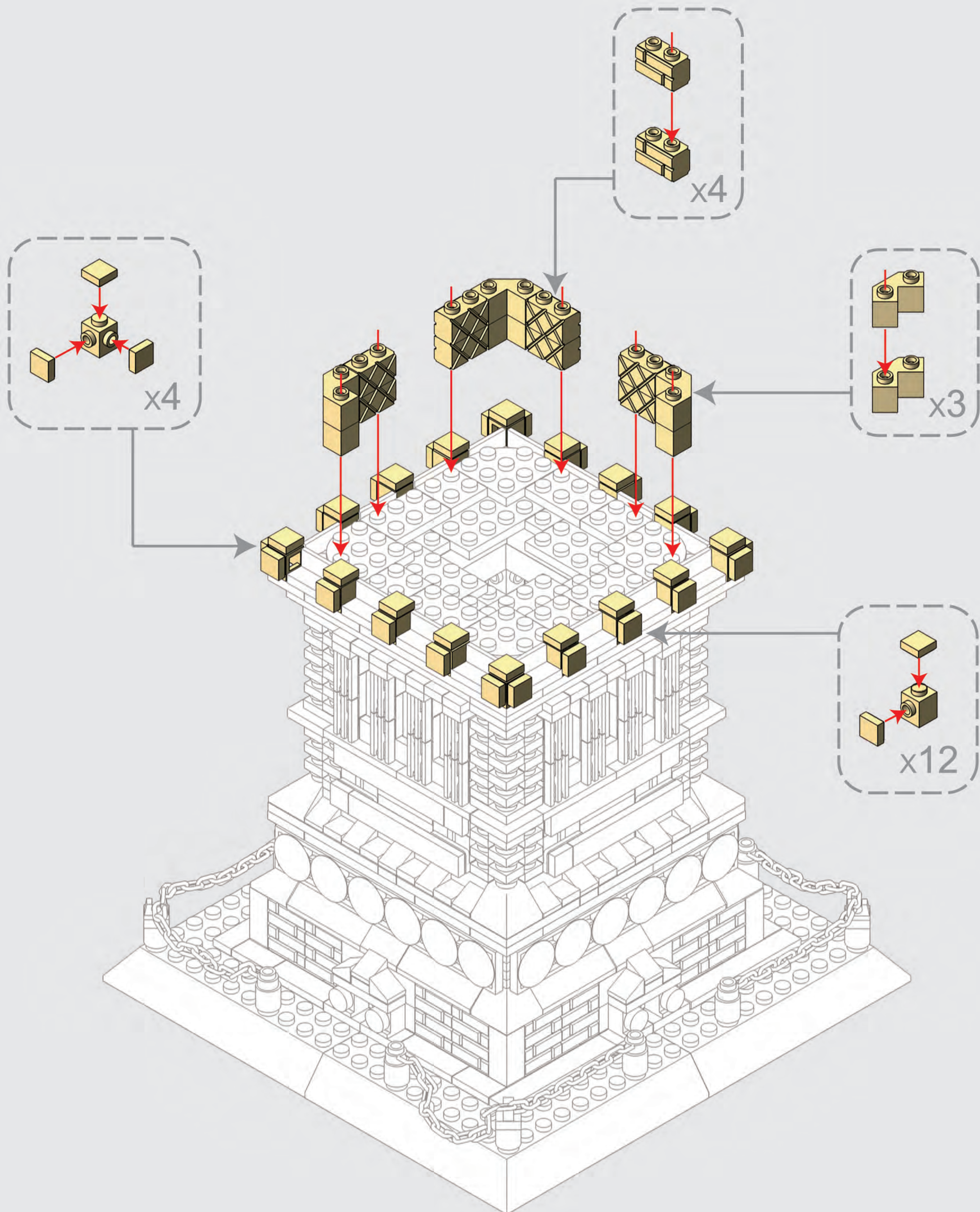

52

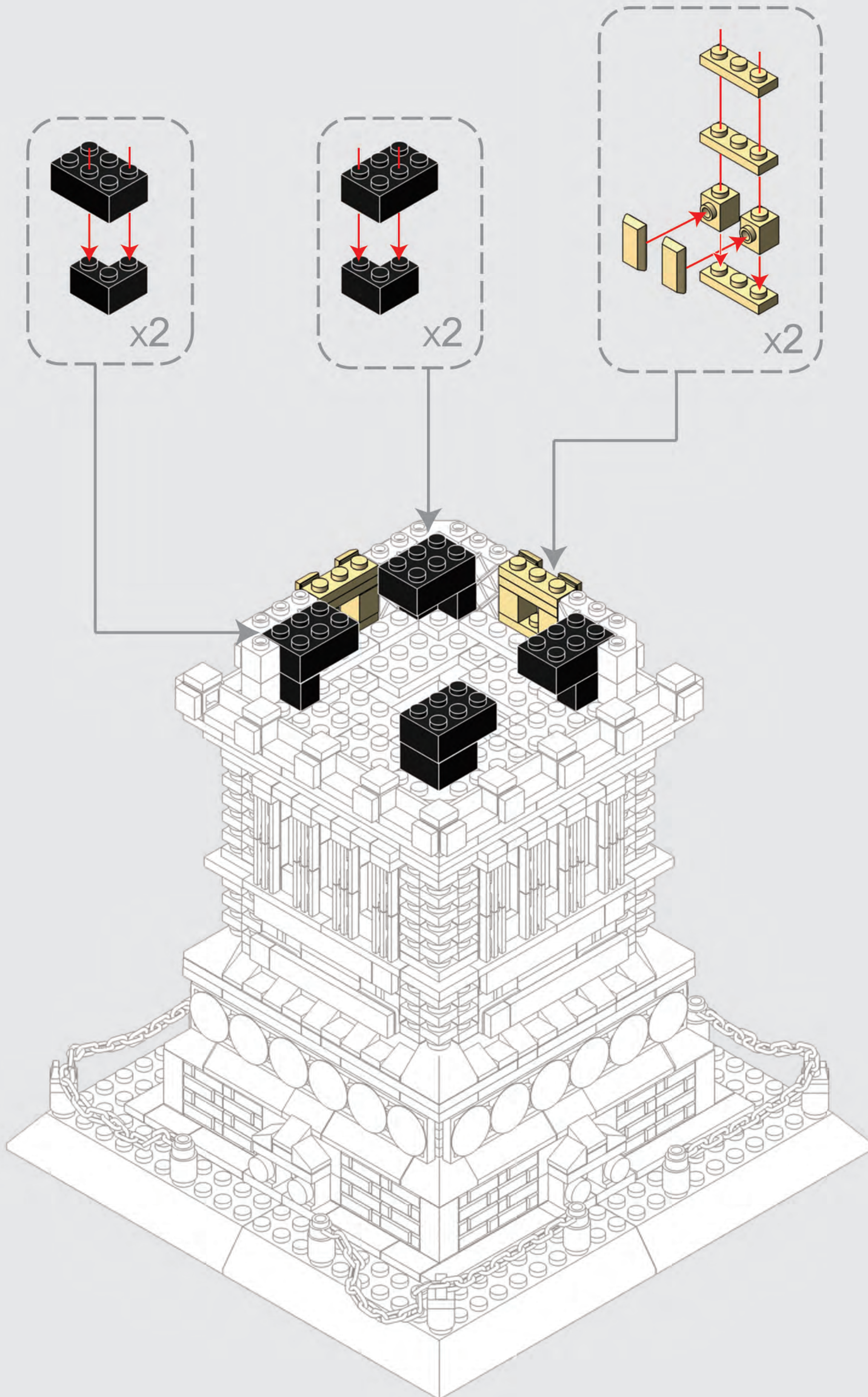
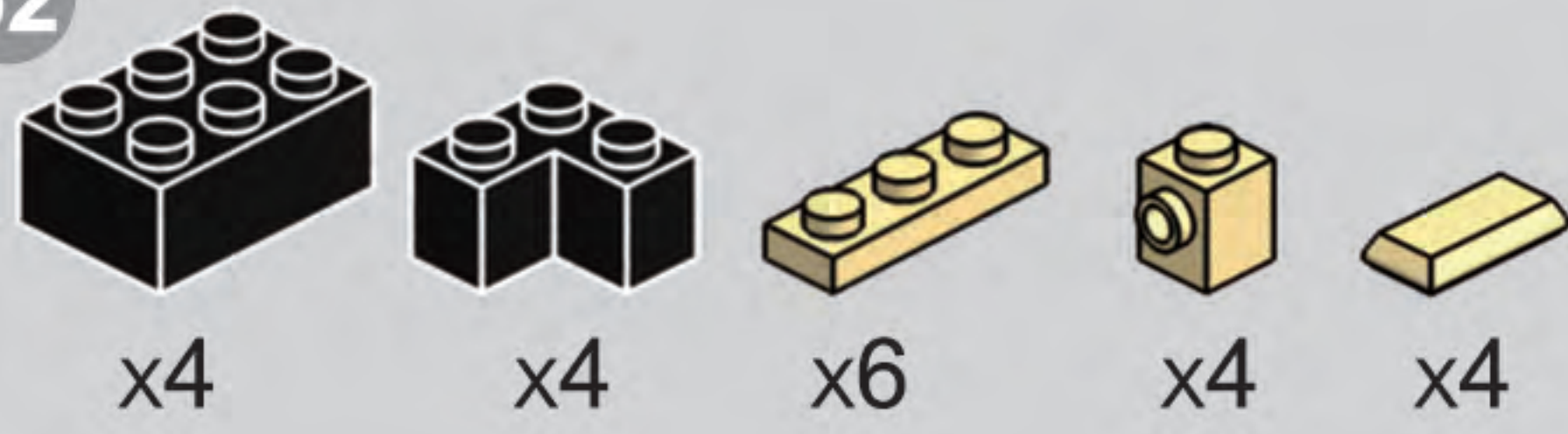

53



x2

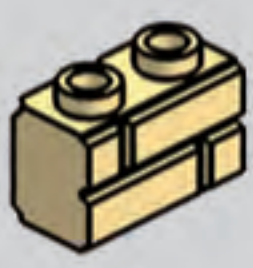

x8

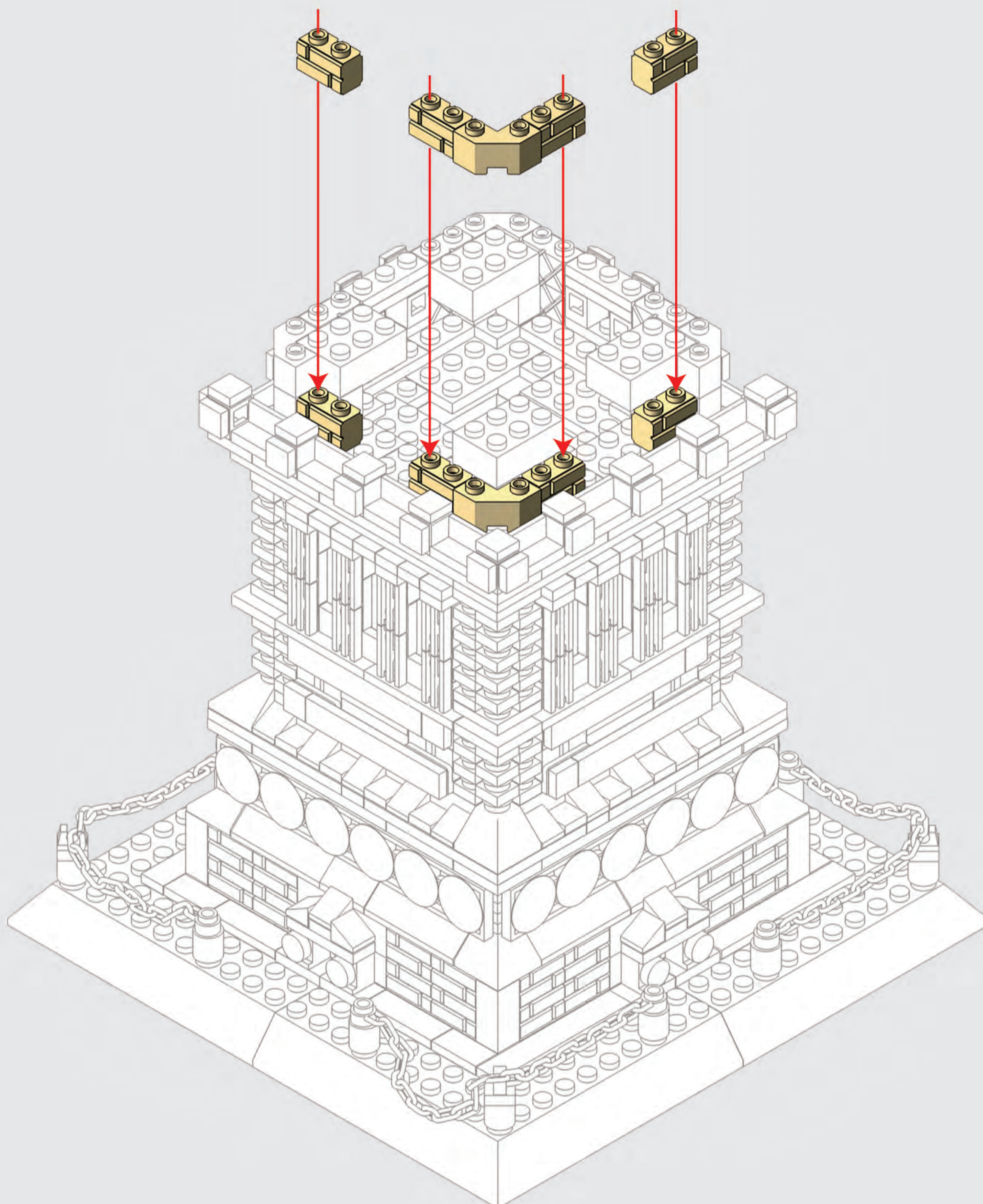

54

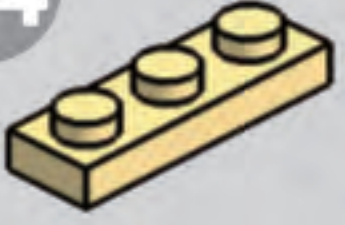

x6



x4



x4

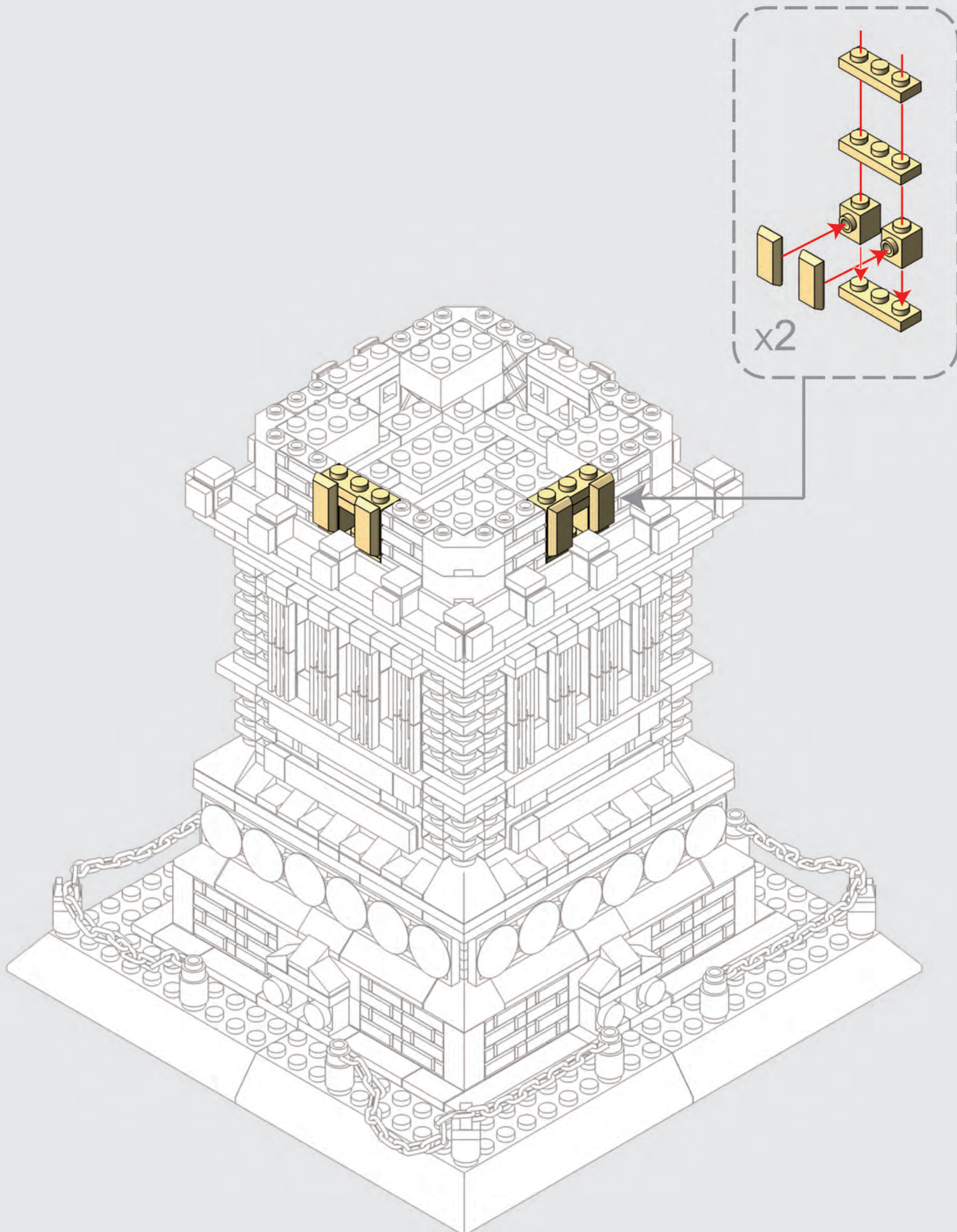

55

1 X 10

2 X 8

1 X 8

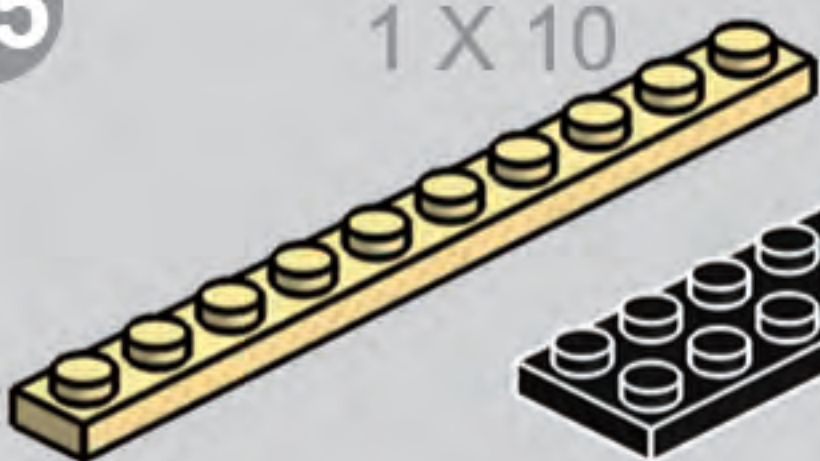

x4

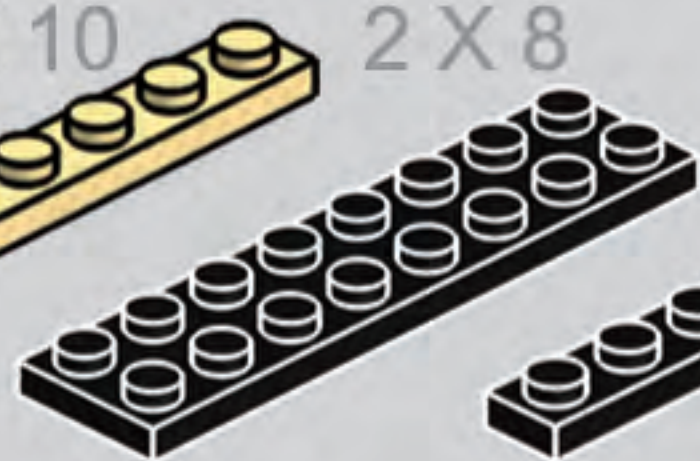

x2

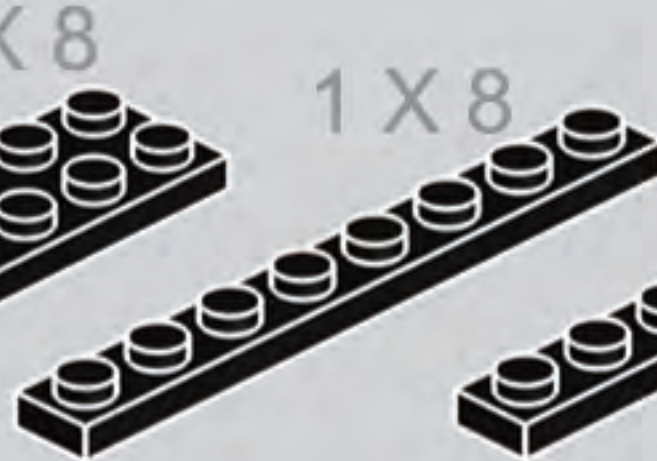

x1



x1



x2

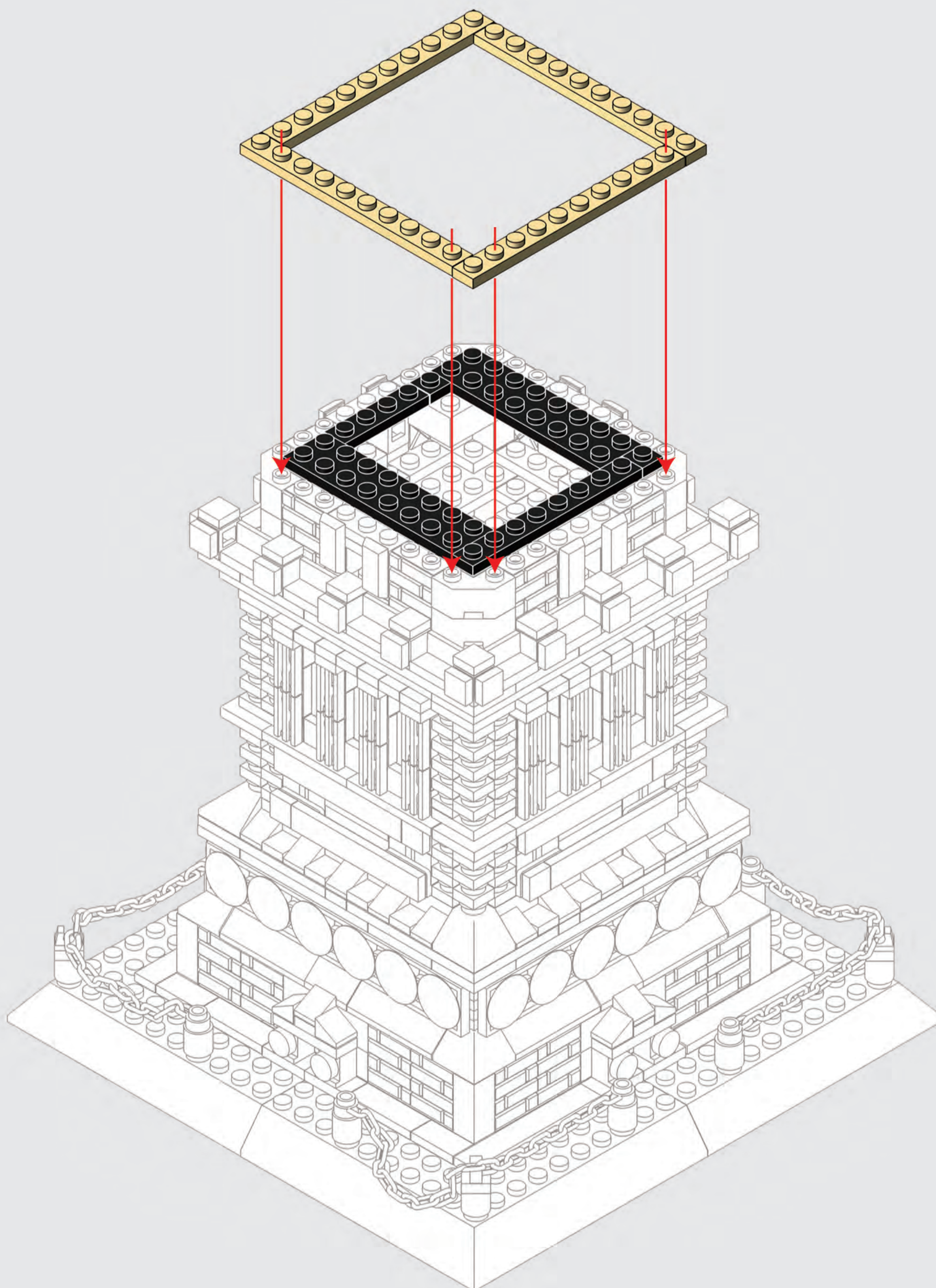

56

1 X 6

1 X 4

x4

x4

x4

x16

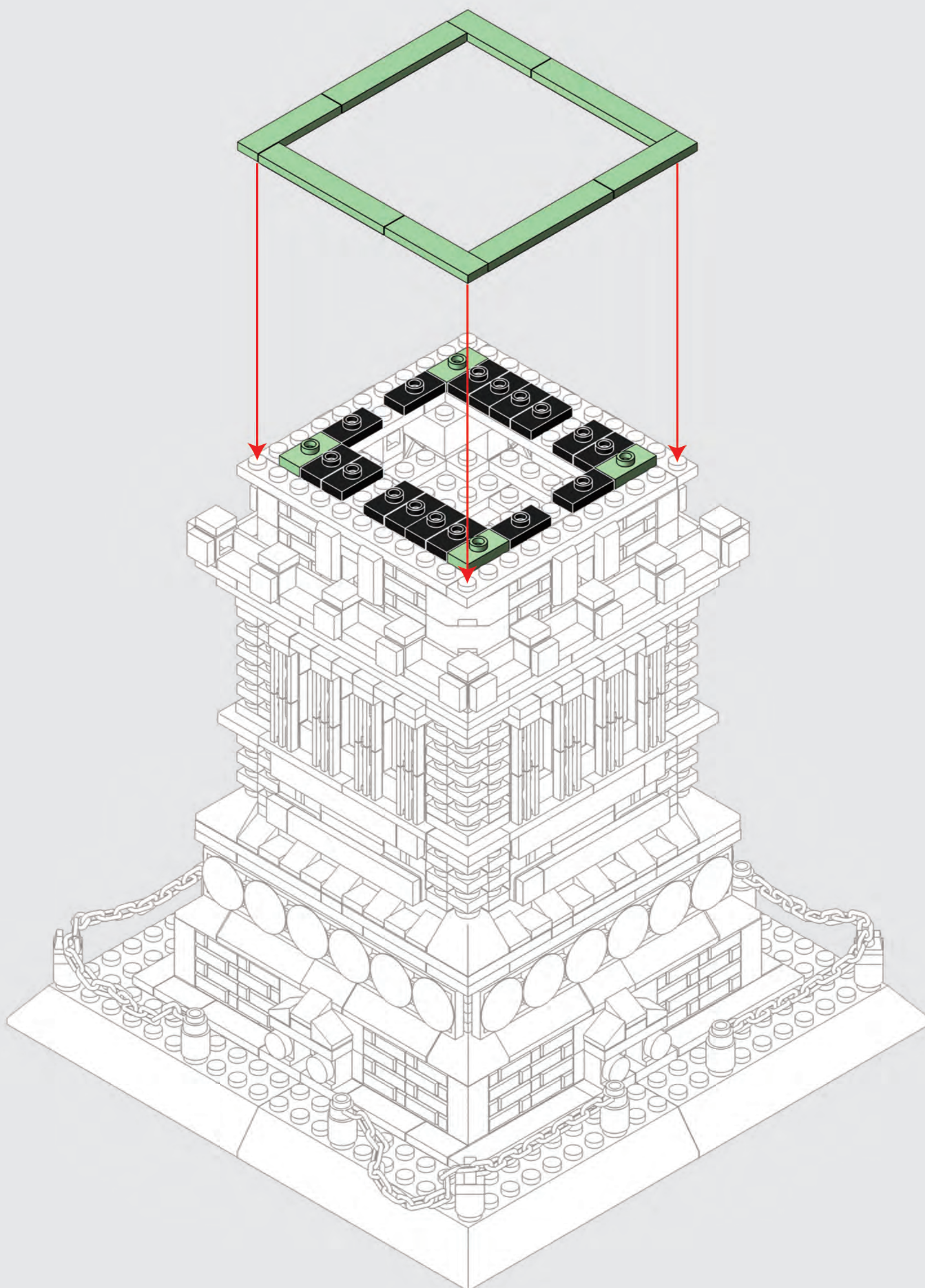

57 1 X 4
 x8 x14 x2

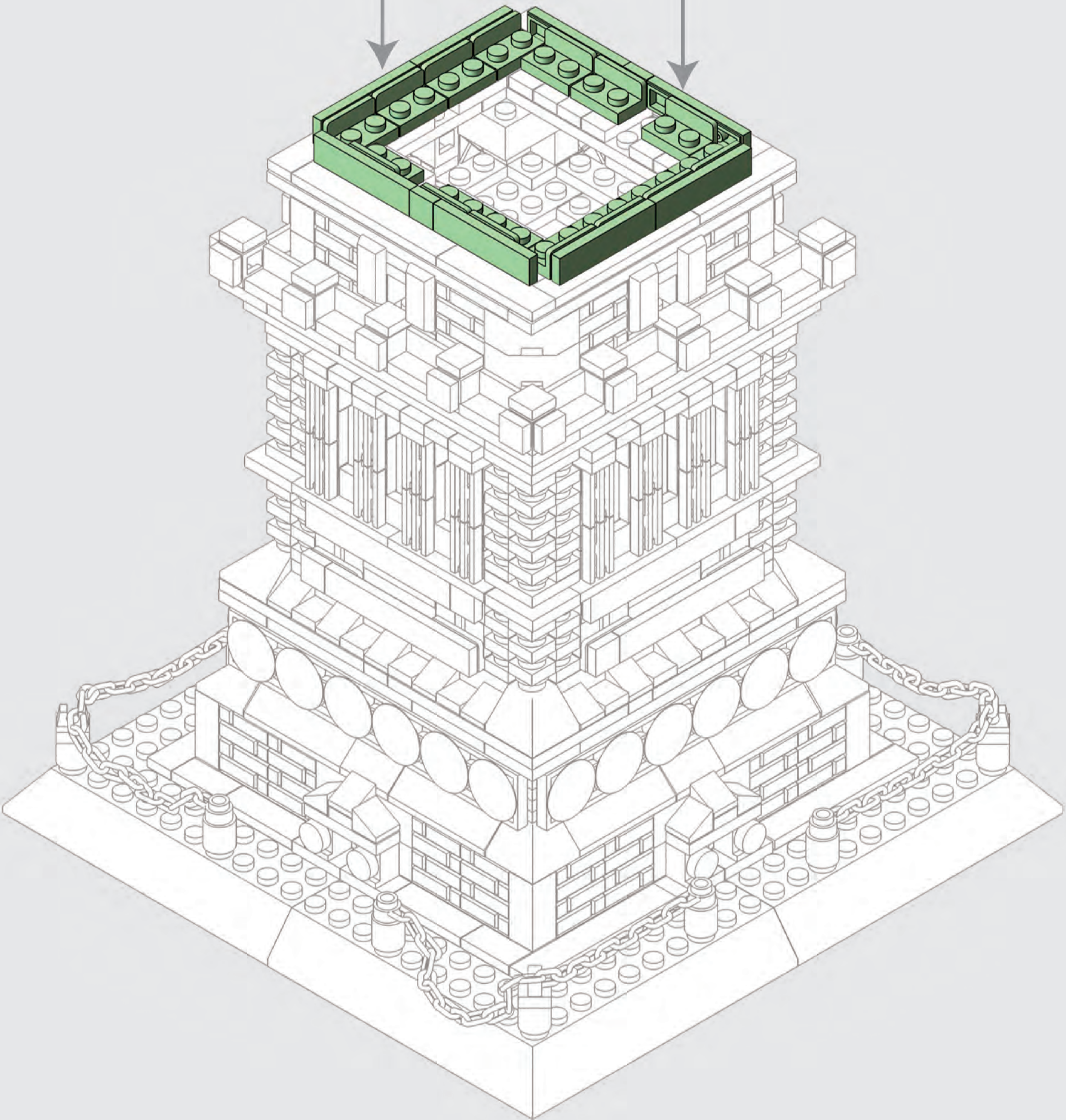
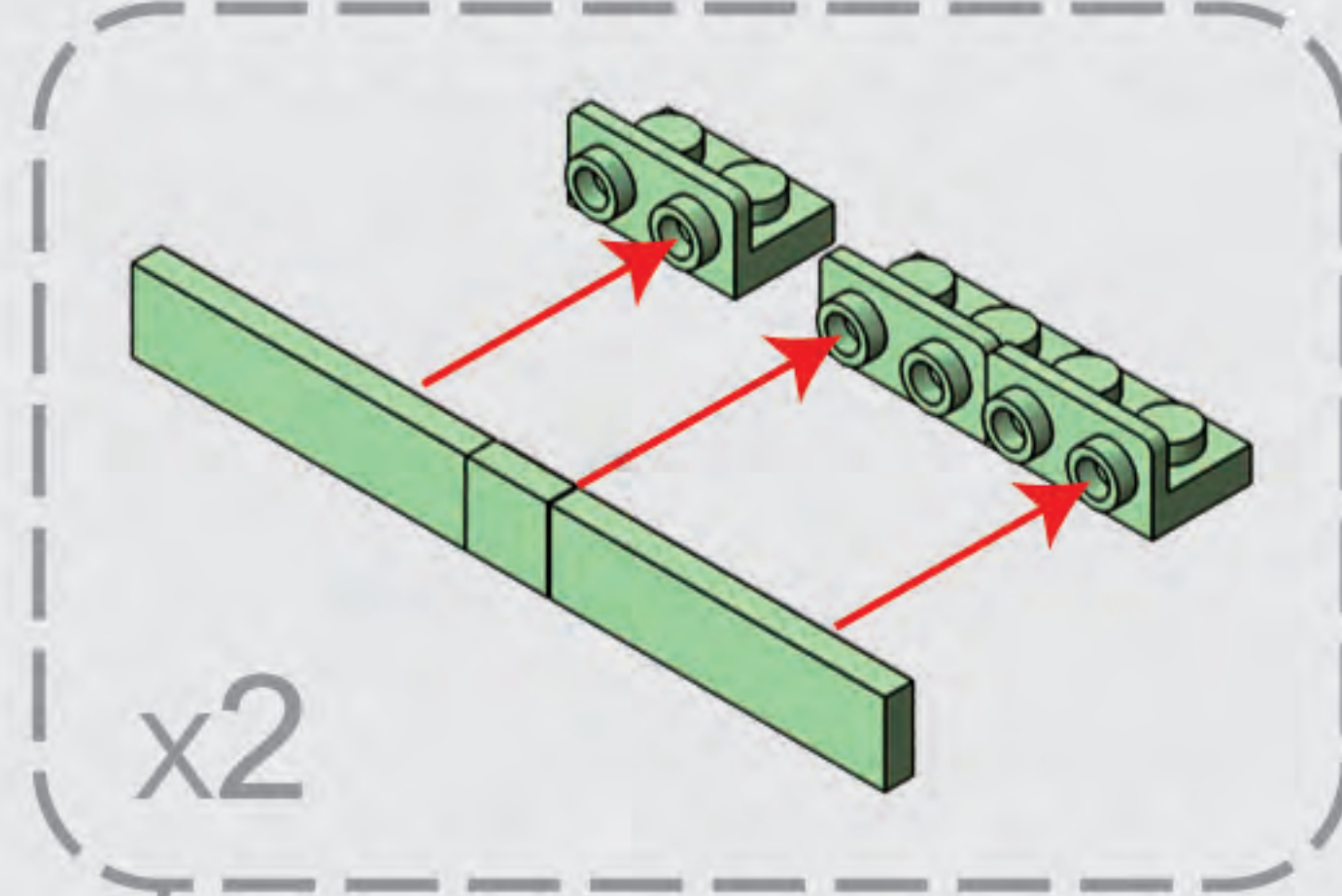
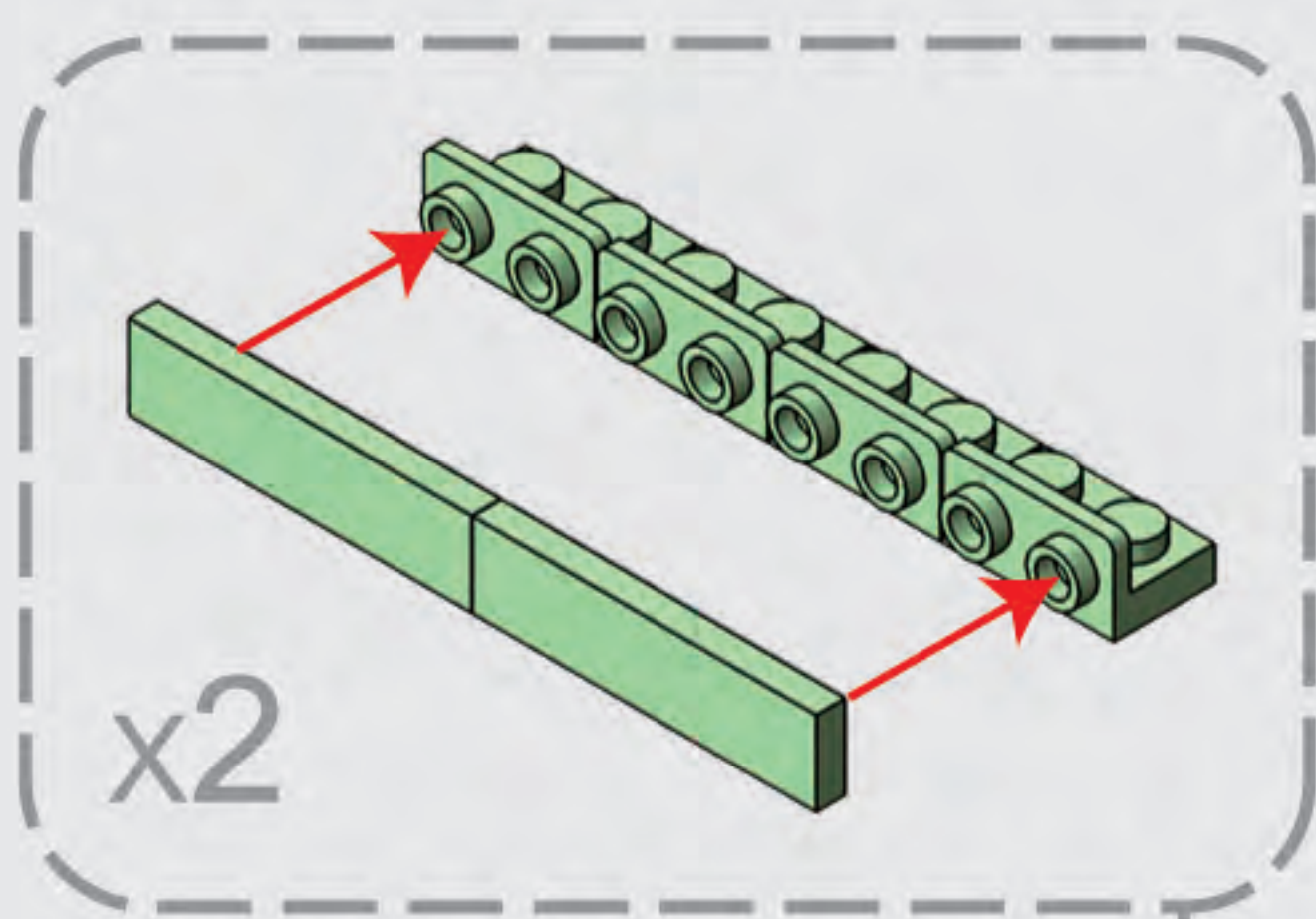

58

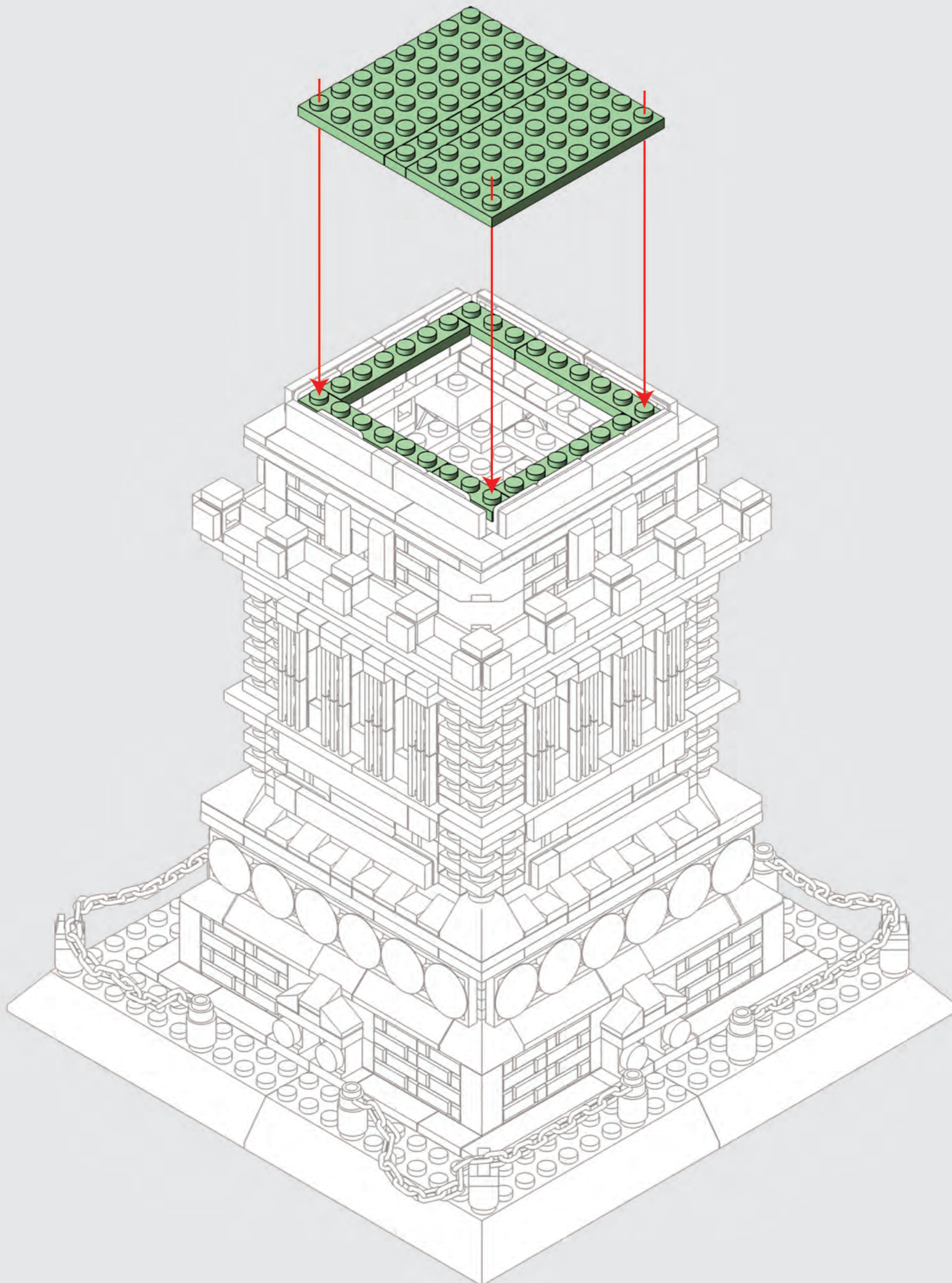
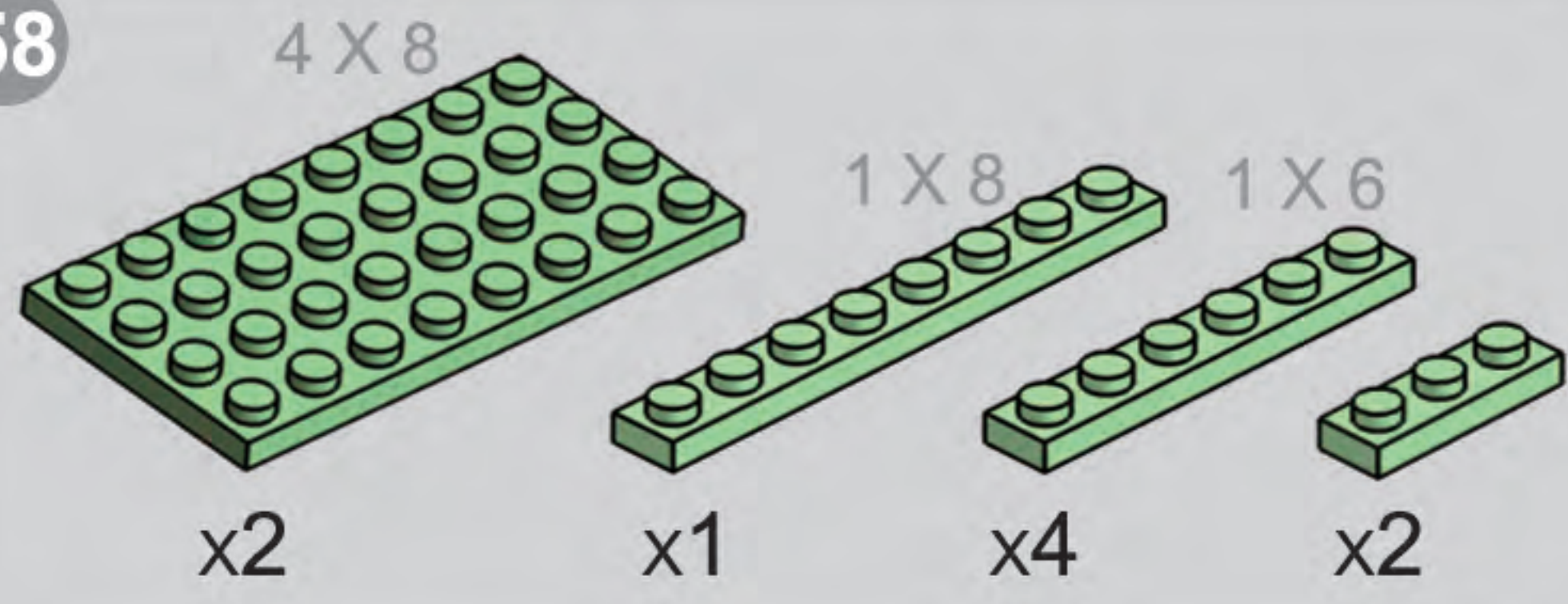

59



x1



x1



x1



x1

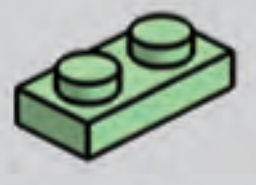

x1



x3

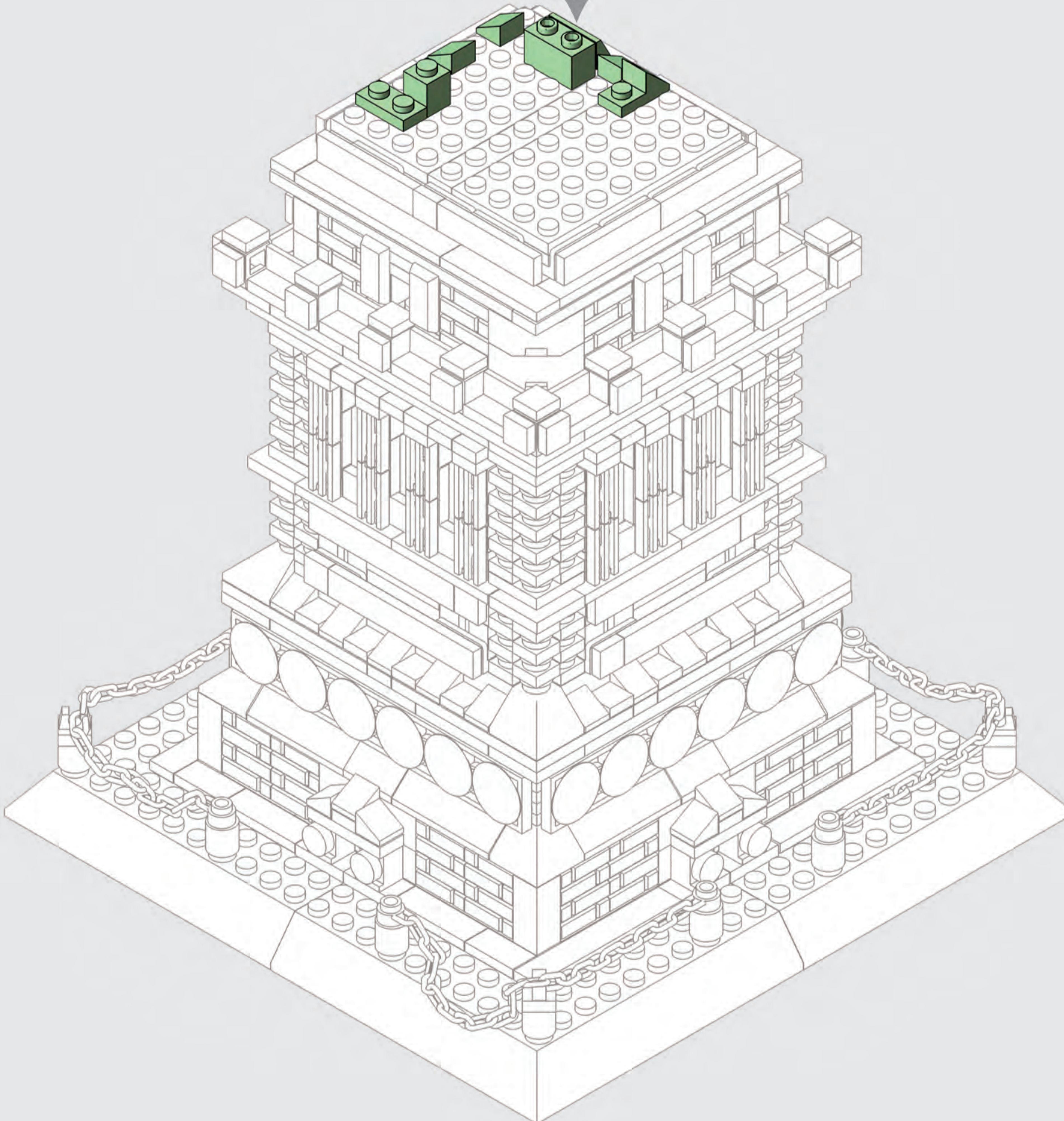
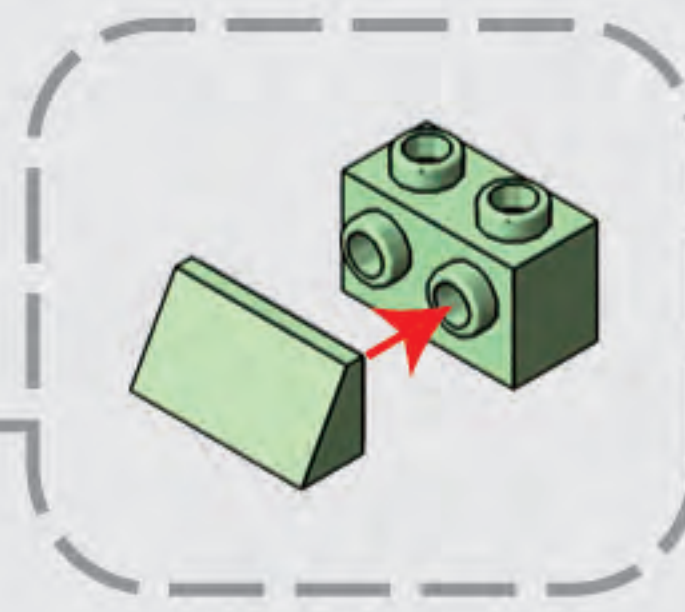

60



x1



x2



x1



x1



x1



x5

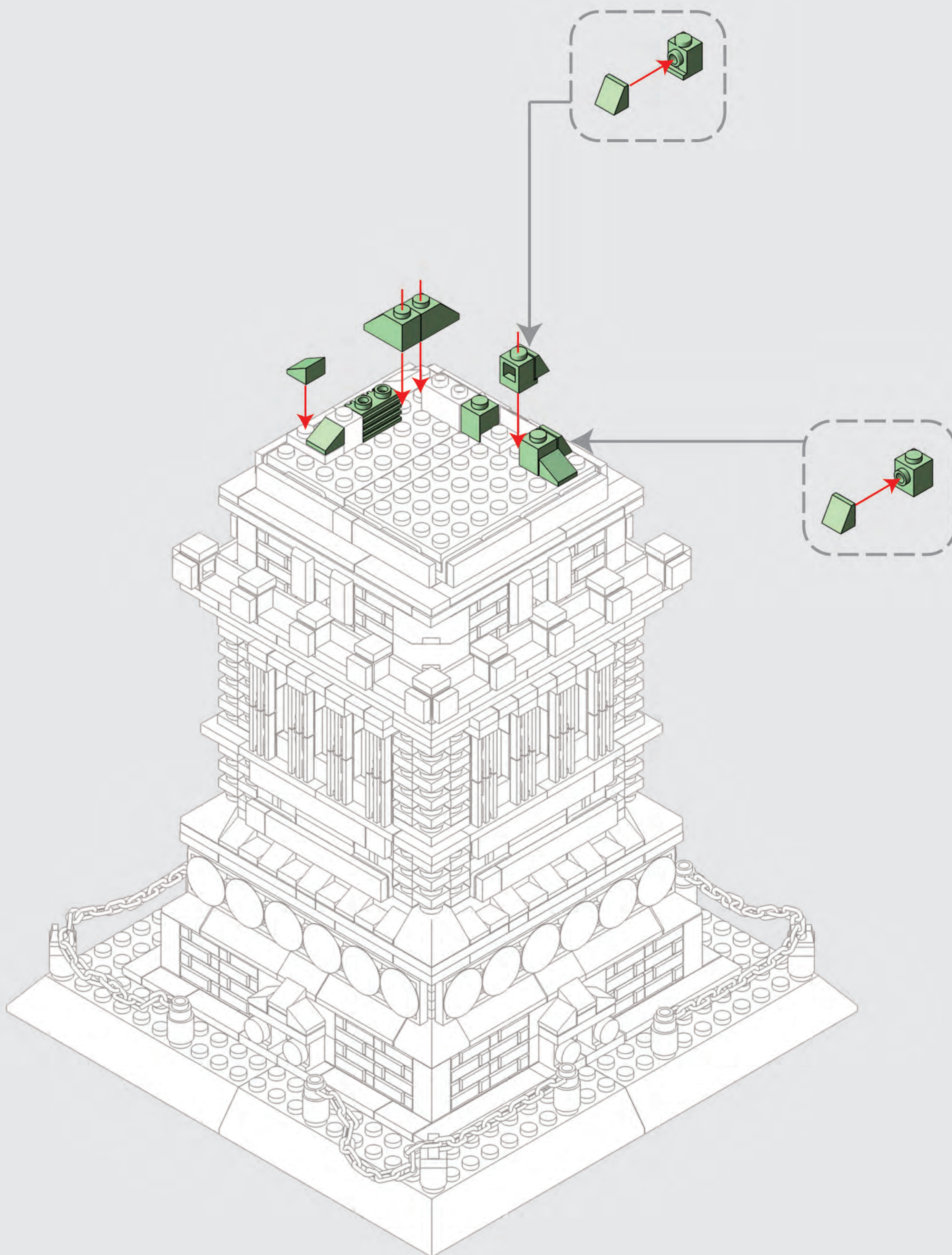

61



x2



x2



x1

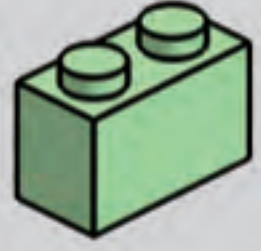

x1



x1



x1

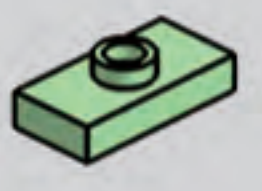

x1



x1

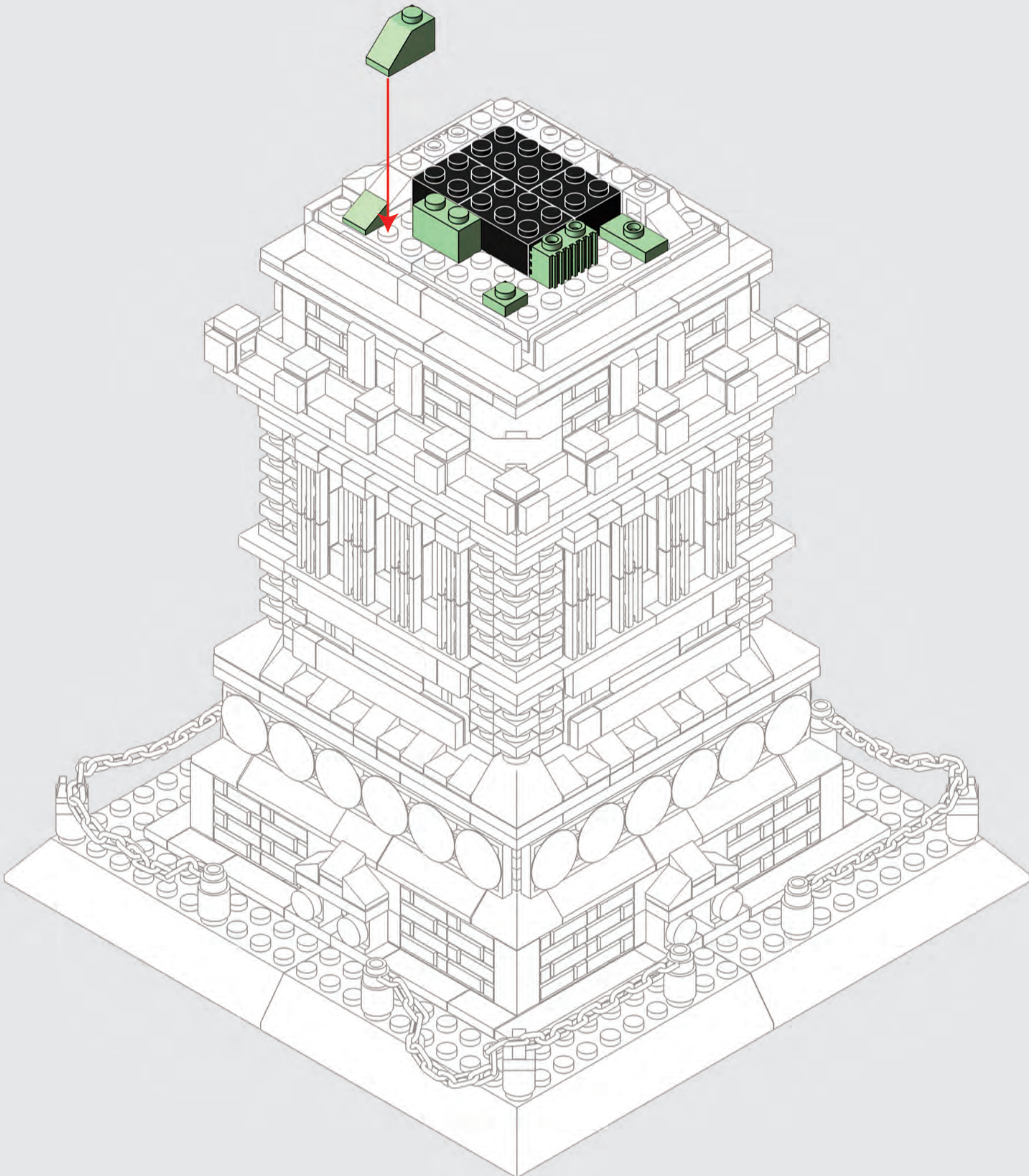

62



x2



x1

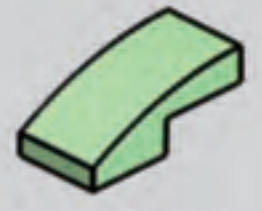

x1



x1



x3



x1

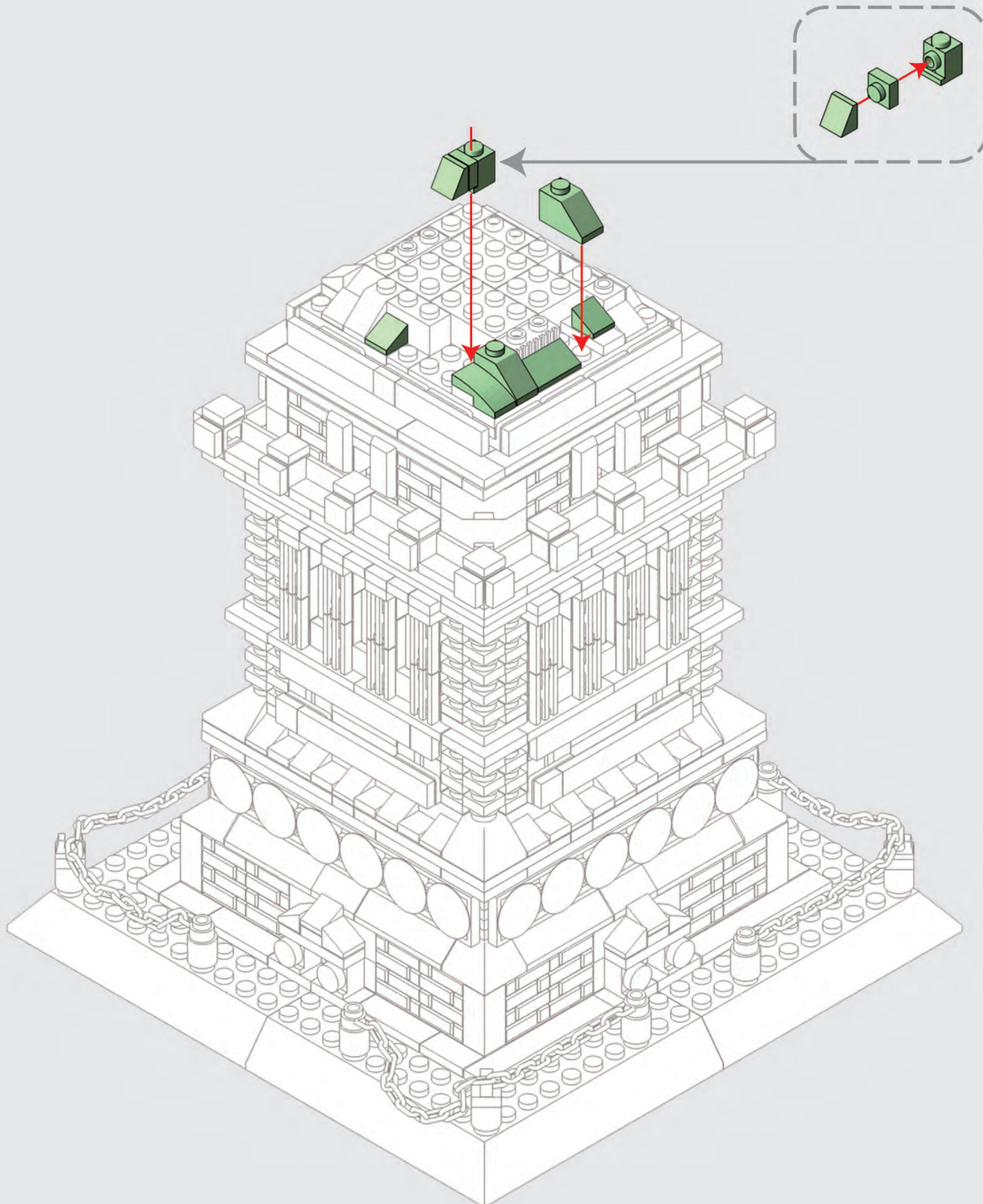

63



x2



x2



x4



x4



x4



x2

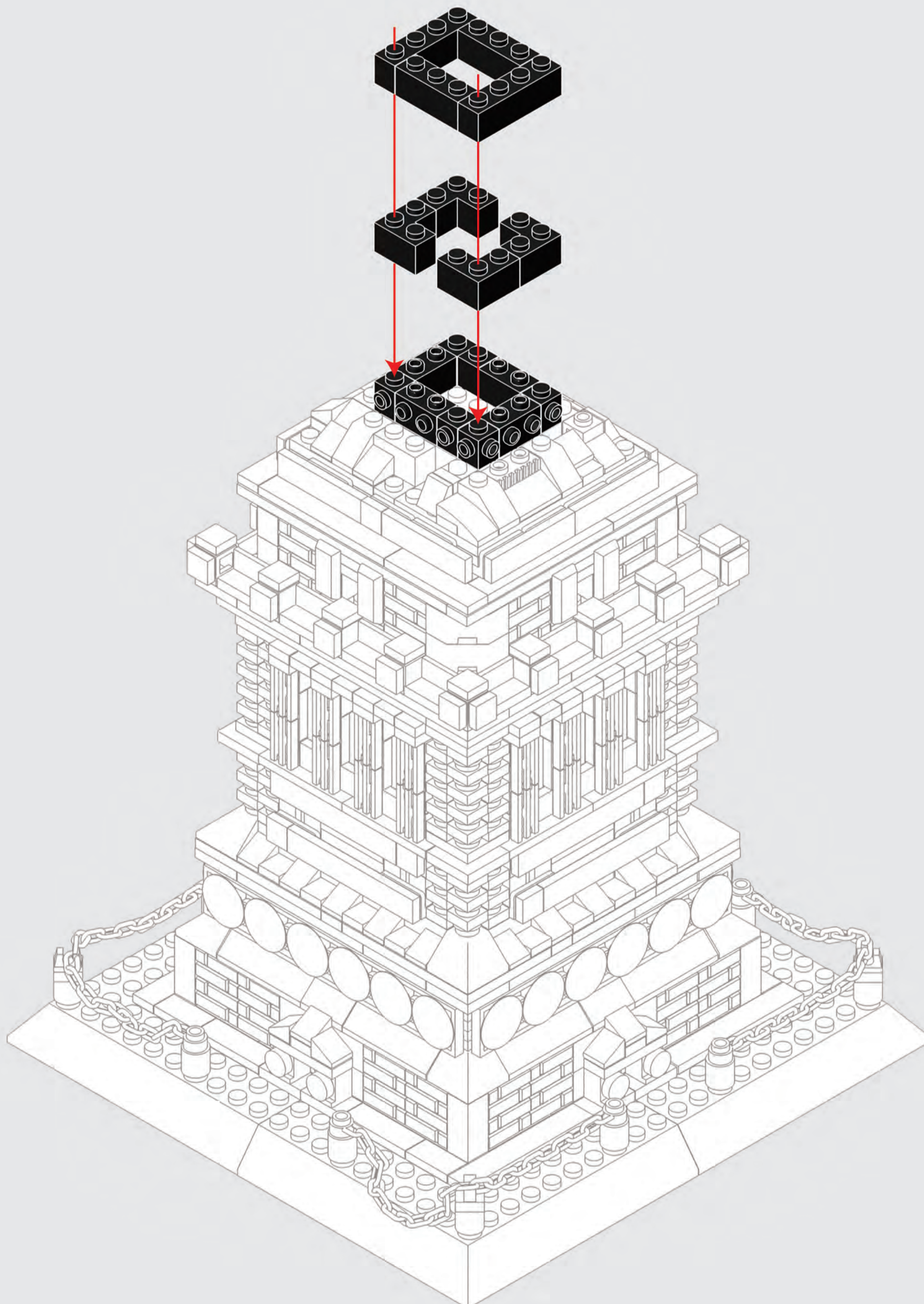

64



x1



x2



x4



x2



x6

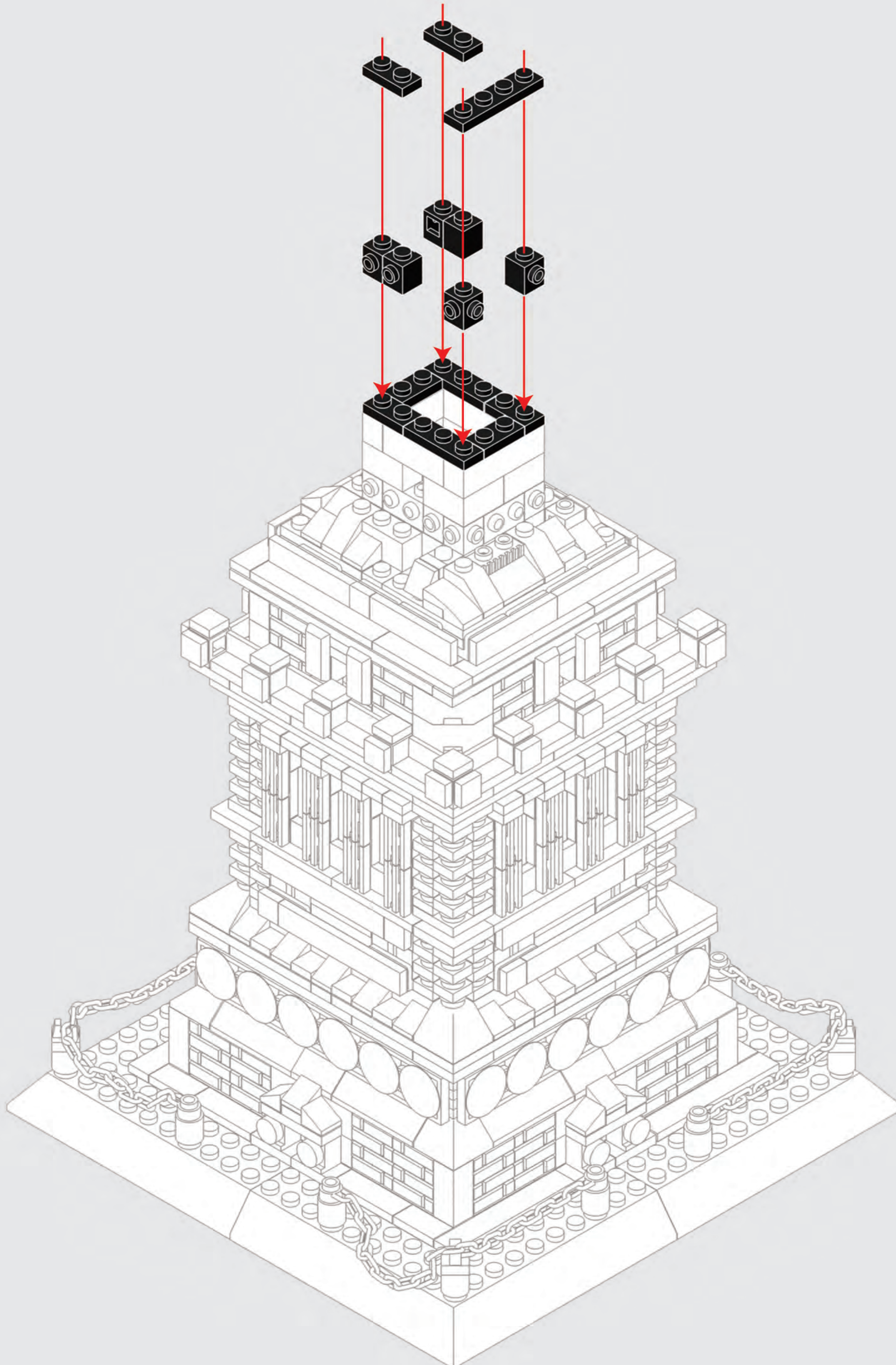



THE STATUE OF LIBERTY OF NEW YORK

INTRODUCTION

The Statue of Liberty is a colossal neoclassical sculpture on Liberty Island in New York Harbor (New York, United States). The copper statue, a gift from the people of France to the people of the United States, was designed by French sculptor Frédéric Auguste Bartholdi and its metal framework was built by Gustave Eiffel. The statue was dedicated on October 28, 1886. The statue is a figure of Libertas, a robed Roman liberty goddess. She holds a torch above her head with her right hand, and in her left hand carries a *tabula ansata* inscribed JULY IV MDCCLXXVI (July 4, 1776 in Roman numerals), the date of the U.S. Declaration of Independence. A broken shackle and chain lie at her feet as she walks forward, commemorating the national abolition of slavery. After its dedication, the statue became an icon of freedom and of the United States; it has been a welcoming sight to immigrants arriving by sea. Bartholdi was inspired by a French law professor and politician, Édouard René de Laboulaye, who is said to have commented in 1865 that any monument raised to U.S. independence would properly be a joint project of the French and U.S. peoples. Because of the post-war instability in France, work on the statue did not commence until the early 1870s. In 1875, Laboulaye proposed that the French finance the statue and the U.S. provide the site and build the pedestal. Bartholdi completed the head and the torch-bearing arm before the statue was fully designed, and these pieces were exhibited for publicity at international expositions. The torch-bearing arm was displayed at the Centennial Exposition in Philadelphia in 1876, and in Madison Square Park in Manhattan from 1876 to 1882. Fundraising proved difficult, especially for the Americans, and by 1885 work on the pedestal was threatened by lack of funds. Publisher Joseph Pulitzer, of the *New York World*, started a drive for donations to finish the project and attracted more than 120,000 contributors, most of whom gave less than a dollar. The statue was built in France, shipped overseas in crates, and assembled on the completed pedestal on what was then called Bedloe's Island. The statue's completion was marked by New York's first ticker-tape parade and a dedication ceremony presided over by President Grover Cleveland.

LA STATUE DE LA LIBERTÉ DE NEW YORK

INTRODUCTION

La Statue de la Liberté est une sculpture néoclassique colossale sur *Liberty Island* dans le port de New York (New York, États-Unis). La statue en cuivre, un cadeau du peuple français au peuple des États-Unis, a été conçue par le sculpteur français Frédéric Auguste Bartholdi et sa charpente métallique a été construite par Gustave Eiffel. La statue a été consacrée le 28 octobre 1886. La statue est une figure de *Libertas*, une déesse de la liberté romaine vêtue d'une robe. Elle tient une torche au-dessus de sa tête avec sa main droite, et dans sa main gauche porte une *tabula ansata* inscrite JULY IV MDCCLXXVI (4 juillet 1776 en chiffres romains), la date de la déclaration d'indépendance des États-Unis. Une chaîne brisée se trouve à ses pieds alors qu'elle avance, commémorant l'abolition nationale de l'esclavage. Après sa consécration, la statue est devenue un icône de la liberté et des États-Unis; un symbole accueillant pour les immigrants arrivant par voie maritime. Bartholdi a été inspiré par un professeur de droit et homme politique français, Édouard René de Laboulaye, qui aurait commenté en 1865 que tout monument élevé à l'indépendance des États-Unis serait à juste titre un projet conjoint des peuples français et américain. En raison de l'instabilité d'après-guerre en France, les travaux sur la statue n'ont commencé qu'au début des années 1870. En 1875, Laboulaye proposa que les Français financent la statue et que les États-Unis fournissent le site et construisent le piédestal. Bartholdi a terminé la tête et le bras porte-torche avant que la statue ne soit entièrement conçue, et ces pièces ont été exposées à des fins publicitaires lors d'expositions internationales. Le bras porte-torche a été exposé à l'exposition du centenaire à Philadelphie en 1876, et au *Madison Square Park* à Manhattan de 1876 à 1882. La collecte de fonds s'avéra difficile, surtout pour les Américains, et en 1885, les travaux sur le piédestal étaient menacés par le manque de fonds. L'éditeur Joseph Pulitzer, du *New York World*, a lancé une campagne de dons pour terminer le projet et a attiré plus de 120 000 contributeurs, dont la plupart ont donné moins d'un dollar. La statue a été construite en France, expédiée à l'étranger dans des caisses, et assemblée sur le piédestal terminé sur ce qui s'appelait alors *Bedloe's Island*. L'achèvement de la statue a été marqué par la première parade avec pluie de confettis à New York et une cérémonie d'inauguration présidée par le président Grover Cleveland.

Manufactured & Distributed by:
Manufacturé & Distribué par :

IMPORTS DRAGON®
2515, avenue de la Renaissance,
Boisbriand, Qc, Canada, J7H 1T9
514.667.0623

 info@importsdragon.com
www.importsdragon.com

MADE IN CHINA /
FABRIQUÉ EN CHINE

1577 PCS
DRAGONBLOK.COM

